

Dør utvendig
DUDA234.002_1490x2090

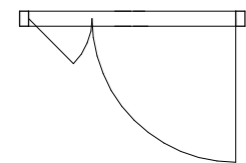

Dør utvendig
DUE234.001_1090x2190

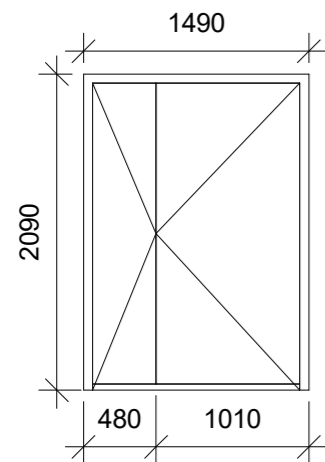
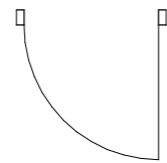
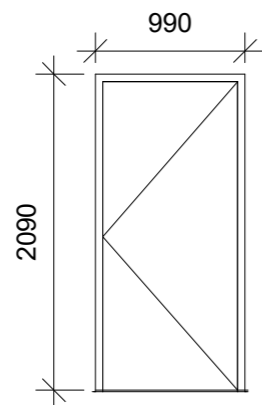

Dør innvendig
DIDS244.001

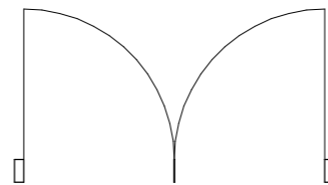
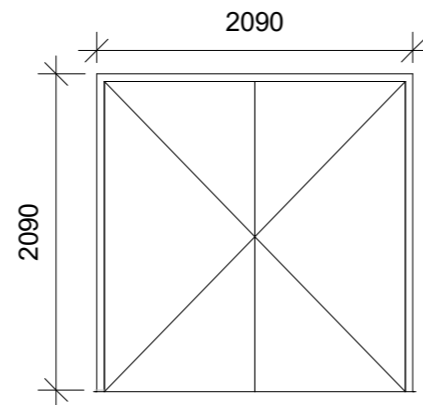

Dørrinnvendig
DIDS244.002

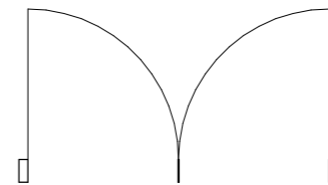
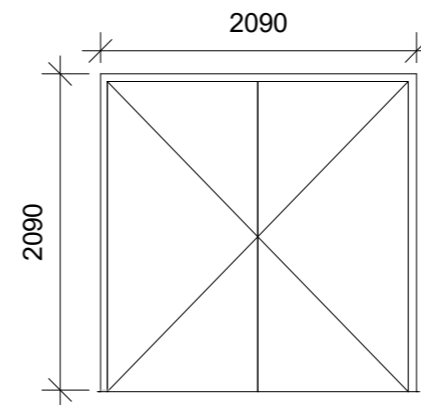

Dør innvendig
DIE244.001

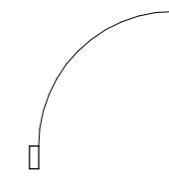
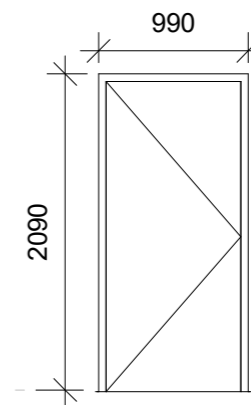

Dør innvendig
DIES244.002

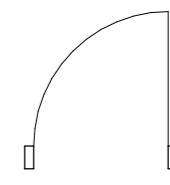
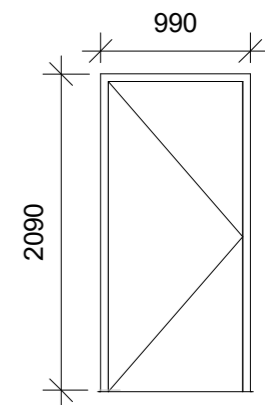

DØRSKJEMA

Type Mark	Type Comments	Width	Height	Fire Rating	Level	Count
DIDS_244.001	NY	2110	2110	EI90CS	Plan 01	1
DIDS_244.002	NY	2110	2110	EI30CS	Plan 01	1
DIE244.001	NY	1010	2110	EI90CS	Plan 01	1
DIE244.001	NY	1010	2110	EI90CS	Plan 01	1
DIE244.001	NY	1010	2110	EI90CS	Plan 01	1
DIE244.002	NY	1010	2110	EI30S	Plan 01	1
DIE244.002	NY	1010	2110	EI30S	Plan 01	1
DIE244.002	NY	1010	2110	EI30S	Plan 01	1
DIE244.002	NY	1010	2110	EI30S	Plan 01	1
DIE244.002	NY	1010	2110	EI30S	Plan 01	1
DIE244.002	NY	1010	2110	EI30S	Plan 01	1
DUDA234.002	NY	1490	2090		Plan 02	1
DUE234.001	NY	1010	2110		Plan 01	1

Grand total: 12

NB! Dette er en orienterende tegning mht. eksisterende forhold.
Det tas forbehold om målriktighet.

Før utførelse og bestilling må alle mål kontrolleres på stedet.
Alle mål på eksisterende bygg som er avgjørende for rett bestilling
av nye komponenter, skal kontrollmåles av entreprenør
før endelige bestillinger.

Rev	Dato	Beskrivelse	Sign	Kontr
		RIK Arkitektur Ryensvingen 5, 8.etg 0680 Oslo Tlf.: 91 91 61 11 E-post: firmapost@rikarkitektur.no	Byggherre Hedmark Fylkeskommune Skolevegen 22 2100 Skarnes	
Prosjekt Skarnes V.G.S.			Fase Tilbudstegning	
Tekst Dørskjema		Prosj.nr. 18429	Målestokk / Format 1 : 50 A3	
		Tegn./Kontr. JK / RR	Opprettet dato 15.11.2018	
Tegningsnr. 18429-A-00-SK-200-004		Disiplin ARK	Revisjon	Status