

16. GRAPHIC ELEMENTS

16.01 LACQUERED ROOM GRAPHIC PANELS (GP-L)

Section	Room	Code	Width (m)	Depth (m)	Height (m)	Side colour	Front colour	Quantity (item)	NOTE	
ANTIQUITY AND DECORATIVE ARTS	1	R01_GP-L-01	0,70	0,06	2,10	NCS S2030-B10G	NCS S8500N	1		
	2	R02_GP-L-01	0,70	0,06	2,10	NCS S2030-B10G	NCS-1500N	1		
	3	R03_GP-L-01	0,70	0,06	2,10	NCS S2030-B10G	NCS S8500N	1		
		R03_GP-L-02	0,70	0,06	2,10	NCS S2030-B10G	NCS S8500N	1		
	4	R04_GP-L-01	0,70	0,06	2,10	NCS S2030-B10G	NCS S8500N	1		
	5	R05_GP-L-01	0,70	0,06	2,10	NCS S2030-B10G	NCS S8500N	1		
	6	R06_GP-L-01	0,70	0,06	2,10	NCS S2030-B10G	NCS S8500N	1		
	7	R07_GP-L-01	0,70	0,06	2,10	NCS S2030-B10G	NCS S8500N	1		
	8	R08_GP-L-01	0,70	0,06	2,10	NCS S2030-B10G	NCS-1500N	1		
	9	R09_GP-L-01	0,70	0,06	2,10	NCS S2030-B10G	NCS-1500N	1		
	10	R10_GP-L-01	0,70	0,06	2,10	NCS S2030-B10G	NCS-1500N	1		
	11	R11_GP-L-01	0,70	0,06	2,10	NCS S2030-B10G	NCS S8500N	1		
	12	-	-	-	-	-	-	-	-	
	13	R13_GP-L-01	0,70	0,06	2,10	NCS S2030-B10G	NCS S8500N	1		
	14	R14_GP-L-01	0,70	0,06	2,10	NCS S2030-B10G	NCS-1500N	1		
	15	R15_GP-L-01	0,70	0,06	2,10	NCS S2030-B10G	NCS-1500N	1		
	16	R16_GP-L-01	0,70	0,06	2,10	NCS S2030-B10G	NCS S8500N	1		
	17	R17_GP-L-01	0,70	0,06	2,10	NCS S2030-B10G	NCS-1500N	1		
18	R18_GP-L-01	0,70	0,06	2,10	NCS S2030-B10G	NCS S8500N	1			
FASHION, STUDIO CRAFTS AND DESIGN	19	R19_GP-L-01	0,70	0,06	2,10	NCS S1075-G90Y	NCS-1500N	1		
	20	R20_GP-L-01	0,70	0,06	2,10	NCS S1075-G90Y	NCS-1500N	1		
	21	R21_GP-L-01	0,70	0,06	2,10	NCS S1075-G90Y	NCS-1500N	1		
		R21_GP-L-02	0,70	0,06	2,10	NCS S1075-G90Y	NCS-1500N	1		
	22	R22_GP-L-01	0,70	0,06	2,10	NCS S1075-G90Y	NCS-1500N	1		
	23	R23_GP-L-01	0,70	0,06	2,10	NCS S1075-G90Y	NCS-1500N	1		
	24	R24_GP-L-01	0,70	0,06	2,10	NCS S1075-G90Y	NCS-1500N	1		
	25	R25_GP-L-01	0,70	0,06	2,10	NCS S1075-G90Y	NCS S8500N	1		
	26	R26_GP-L-01	0,70	0,06	2,10	NCS S1075-G90Y	NCS-1500N	1		
	27	-	-	-	-	-	-	-	-	
	28	R28_GP-L-01	0,70	0,06	2,10	NCS S1075-G90Y	NCS-1500N	1		
	29	R29_GP-L-01	0,70	0,06	2,10	NCS S1075-G90Y	NCS-1500N	1		
	30	R30_GP-L-01	0,70	0,06	2,10	NCS S1075-G90Y	NCS-1500N	1		
31	R31_GP-L-01	0,70	0,06	2,10	NCS S1075-G90Y	NCS S8500N	1			
ART 1500-1900	33	R33_GP-L-01	0,70	0,06	2,10	NCS S2070-Y80R	NCS S5010-Y50R	1		
	34	R34_GP-L-01	0,70	0,06	2,10	NCS S2070-Y80R	NCS S5010-Y50R	1		
	35	R35_GP-L-01	0,70	0,06	2,10	NCS S2070-Y80R	NCS S5010-Y50R	1		
	36	R36_GP-L-01	0,70	0,06	2,10	NCS S2070-Y80R	NCS S5010-Y50R	1		
	37	R37_GP-L-01	0,70	0,06	2,10	NCS S2070-Y80R	NCS S5010-Y50R	1		
	38	R38_GP-L-01	0,70	0,06	2,10	NCS S2070-Y80R	NCS S5010-Y50R	1		
	39	R39_GP-L-01	0,70	0,06	2,10	NCS S2070-Y80R	NCS S3020-G80Y	1		

16.01 LACQUERED ROOM GRAPHIC PANELS (GP-L)

Section	Room	Code	Width (m)	Depth (m)	Height (m)	Side colour	Front colour	Quantity (item)	NOTE
ART 1500-1900	40	R40_GP-L-01	0,70	0,06	2,10	NCS S2070-Y80R	NCS S3020-G80Y	1	
	41	R41_GP-L-01	0,70	0,06	2,10	NCS S2070-Y80R	NCS S3020-G80Y	1	
	42	R42_GP-L-01	0,70	0,06	2,10	NCS S2070-Y80R	NCS S3020-G80Y	1	
	43	R43_GP-L-01	0,70	0,06	2,10	NCS S2070-Y80R	NCS S3020-G80Y	1	
	44	R44_GP-L-01	0,70	0,06	2,10	NCS S2070-Y80R	NCS S3020-G80Y	1	
	45	R45_GP-L-01	0,70	0,06	2,10	NCS S2070-Y80R	NCS S4010-G10Y	1	
	46	R46_GP-L-01	0,70	0,06	2,10	NCS S2070-Y80R	NCS S4010-G10Y	1	
	47	R47_GP-L-01	0,70	0,06	2,10	NCS S2070-Y80R	NCS S4010-G10Y	1	
	48	R48_GP-L-01	0,70	0,06	2,10	NCS S2070-Y80R	NCS S2010-Y30R	1	
	49	R49_GP-L-01	0,70	0,06	2,10	NCS S2070-Y80R	NCS S6005-B20G	1	
	50	R50_GP-L-01	0,70	0,06	2,10	NCS S2070-Y80R	NCS S6005-B20G	1	
	51	R51_GP-L-01	0,70	0,06	2,10	NCS S2070-Y80R	NCS S6005-B20G	1	
	52	R52_GP-L-01	0,70	0,06	2,10	NCS S2070-Y80R	NCS S6005-B20G	1	
	53	R53_GP-L-01	0,70	0,06	2,10	NCS S2070-Y80R	NCS S1005-Y20R	1	
	54	R54_GP-L-01	0,70	0,06	2,10	NCS S2070-Y80R	NCS S1005-Y20R	1	
	55	R55_GP-L-01	0,70	0,06	2,10	NCS S2070-Y80R	NCS S1005-Y20R	1	
	57	R57_GP-L-01	0,70	0,06	2,10	NCS S2070-Y80R	NCS S5020-B	1	
	58	R58_GP-L-01	0,70	0,06	2,10	NCS S2070-Y80R	NCS S5020-B	1	
	59	R59_GP-L-01	0,70	0,06	2,10	NCS S2070-Y80R	TBD	1	
	60	R60_GP-L-01	0,70	0,06	2,10	NCS S2070-Y80R	TBD	1	
61	R61_GP-L-01	0,70	0,06	2,10	NCS S2070-Y80R	NCS S7010-R70B	1		
ART 1900-1970	63	R63_GP-L-01	0,70	0,06	2,10	NCS S3060-R90B	NCS S2000-N	1	
	64	R64_GP-L-01	0,70	0,06	2,10	NCS S3060-R90B	NCS S6500-N	1	
	65	R65_GP-L-01	0,70	0,06	2,10	NCS S3060-R90B	NCS S4005-B20G	1	
ARCHITECTURE	66	R66_GP-L-01	0,70	0,06	2,10	NCS S2005-Y	NCS S2000-N	1	
ART 1900-1970	67	R67_GP-L-01	0,70	0,06	2,10	NCS S3060-R90B	NCS S2000-N	1	
	68	R68_GP-L-01	0,70	0,06	2,10	NCS S3060-R90B	NCS S1510-Y20R	1	
	70	R70_GP-L-01	0,70	0,06	2,10	NCS S3060-R90B	NCS S0500-N	1	
	71	R71_GP-L-01	0,70	0,06	2,10	NCS S3060-R90B	NCS S0500-N	1	
	72	R72_GP-L-01	0,70	0,06	2,10	NCS S3060-R90B	NCS S8010-R90B	1	
	73	R73_GP-L-01	0,70	0,06	2,10	NCS S3060-R90B	NCS S2000-N	1	
	74	R74_GP-L-01	0,70	0,06	2,10	NCS S3060-R90B	NCS S4050-Y70R	1	
ARCHITECTURE	77	R77_GP-L-01	0,70	0,06	2,10	NCS S2005-Y	NCS S2000-N	1	
TOTAL								71	

16.04 ROOM NUMBERS ON WALL

Section	Room	Width (m)	Depth (m)	Height (m)	Font	Side colour	Front colour	Quantity (item)	NOTE
ANTIQUITY AND DECORATIVE ARTS	1	variable	0,05	0,30	Goudy Bold Oldstyle Figures	NCS S2030-B10G	NCS S8500N	1	
	2	variable	0,05	0,30	Goudy Bold Oldstyle Figures	NCS S2030-B10G	NCS-1500N	1	
	3	variable	0,05	0,30	Goudy Bold Oldstyle Figures	NCS S2030-B10G	NCS S8500N	1	
	4	variable	0,05	0,30	Goudy Bold Oldstyle Figures	NCS S2030-B10G	NCS S8500N	1	
	5	variable	0,05	0,30	Goudy Bold Oldstyle Figures	NCS S2030-B10G	NCS S8500N	1	
	6	variable	0,05	0,30	Goudy Bold Oldstyle Figures	NCS S2030-B10G	NCS S8500N	1	
	7	variable	0,05	0,30	Goudy Bold Oldstyle Figures	NCS S2030-B10G	NCS S8500N	1	
	8	variable	0,05	0,30	Goudy Bold Oldstyle Figures	NCS S2030-B10G	NCS-1500N	1	
	9	variable	0,05	0,30	Goudy Bold Oldstyle Figures	NCS S2030-B10G	NCS-1500N	1	
	10	variable	0,05	0,30	Goudy Bold Oldstyle Figures	NCS S2030-B10G	NCS-1500N	1	
	11	variable	0,05	0,30	Goudy Bold Oldstyle Figures	NCS S2030-B10G	NCS S8500N	1	
	12	-	-	-	-	-	-	0	
	13	variable	0,05	0,30	Goudy Bold Oldstyle Figures	NCS S2030-B10G	NCS S8500N	1	
	14	variable	0,05	0,30	Goudy Bold Oldstyle Figures	NCS S2030-B10G	NCS-1500N	1	
	15	variable	0,05	0,30	Goudy Bold Oldstyle Figures	NCS S2030-B10G	NCS-1500N	1	
	16	variable	0,05	0,30	Goudy Bold Oldstyle Figures	NCS S2030-B10G	NCS S8500N	1	
	17	variable	0,05	0,30	Goudy Bold Oldstyle Figures	NCS S2030-B10G	NCS-1500N	1	
	18	variable	0,05	0,30	Goudy Bold Oldstyle Figures	NCS S2030-B10G	NCS S8500N	1	
DESIGN	19	variable	0,05	0,30	Conduit ITC - BOLD	NCS S1075-G90Y	NCS-1500N	1	
	20	variable	0,05	0,30	Conduit ITC - BOLD	NCS S1075-G90Y	NCS-1500N	1	
	21	variable	0,05	0,30	Conduit ITC - BOLD	NCS S1075-G90Y	NCS-1500N	1	
	22	variable	0,05	0,30	Conduit ITC - BOLD	NCS S1075-G90Y	NCS-1500N	1	
	23	variable	0,05	0,30	Conduit ITC - BOLD	NCS S1075-G90Y	NCS-1500N	1	
	24	variable	0,05	0,30	Conduit ITC - BOLD	NCS S1075-G90Y	NCS-1500N	1	
	25	variable	0,05	0,30	Conduit ITC - BOLD	NCS S1075-G90Y	NCS S8500N	1	
	26	variable	0,05	0,30	Conduit ITC - BOLD	NCS S1075-G90Y	NCS-1500N	1	
	27	-	-	-	-	-	-	0	
	28	variable	0,05	0,30	Conduit ITC - BOLD	NCS S1075-G90Y	NCS-1500N	1	
	29	variable	0,05	0,30	Conduit ITC - BOLD	NCS S1075-G90Y	NCS-1500N	1	
	30	variable	0,05	0,30	Conduit ITC - BOLD	NCS S1075-G90Y	NCS-1500N	1	
	31	variable	0,05	0,30	Conduit ITC - BOLD	NCS S1075-G90Y	NCS S8500N	1	
	32	-	-	-	-	-	-	0	
	33	variable	0,05	0,30	Centaur MT - REGULAR	NCS S2070-Y80R	NCS S5010-Y50R	1	
	34	variable	0,05	0,30	Centaur MT - REGULAR	NCS S2070-Y80R	NCS S5010-Y50R	1	
	35	variable	0,05	0,30	Centaur MT - REGULAR	NCS S2070-Y80R	NCS S5010-Y50R	1	
	36	variable	0,05	0,30	Centaur MT - REGULAR	NCS S2070-Y80R	NCS S5010-Y50R	1	
	37	variable	0,05	0,30	Centaur MT - REGULAR	NCS S2070-Y80R	NCS S5010-Y50R	1	
	38	variable	0,05	0,30	Centaur MT - REGULAR	NCS S2070-Y80R	NCS S5010-Y50R	1	
	39	variable	0,05	0,30	Centaur MT - REGULAR	NCS S2070-Y80R	NCS S3020-G80Y	1	
	40	variable	0,05	0,30	Centaur MT - REGULAR	NCS S2070-Y80R	NCS S3020-G80Y	1	
	41	variable	0,05	0,30	Centaur MT - REGULAR	NCS S2070-Y80R	NCS S3020-G80Y	1	

16.04 ROOM NUMBERS ON WALL

Section	Room	Width (m)	Depth (m)	Height (m)	Font	Side colour	Front colour	Quantity (item)	NOTE
OLD MASTERS	42	variable	0,05	0,30	Centaur MT - REGULAR	NCS S2070-Y80R	NCS S3020-G80Y	1	
	43	variable	0,05	0,30	Centaur MT - REGULAR	NCS S2070-Y80R	NCS S3020-G80Y	1	
	44	variable	0,05	0,30	Centaur MT - REGULAR	NCS S2070-Y80R	NCS S3020-G80Y	1	
	45	variable	0,05	0,30	Centaur MT - REGULAR	NCS S2070-Y80R	NCS S4010-G10Y	1	
	46	variable	0,05	0,30	Centaur MT - REGULAR	NCS S2070-Y80R	NCS S4010-G10Y	1	
	47	variable	0,05	0,30	Centaur MT - REGULAR	NCS S2070-Y80R	NCS S4010-G10Y	1	
	48	variable	0,05	0,30	Centaur MT - REGULAR	NCS S2070-Y80R	NCS S2010-Y30R	1	
	49	variable	0,05	0,30	Centaur MT - REGULAR	NCS S2070-Y80R	NCS S6005-B20G	1	
	50	variable	0,05	0,30	Centaur MT - REGULAR	NCS S2070-Y80R	NCS S6005-B20G	1	
	51	variable	0,05	0,30	Centaur MT - REGULAR	NCS S2070-Y80R	NCS S6005-B20G	1	
	52	variable	0,05	0,30	Centaur MT - REGULAR	NCS S2070-Y80R	NCS S6005-B20G	1	
	53	variable	0,05	0,30	Centaur MT - REGULAR	NCS S2070-Y80R	NCS S1005-Y20R	1	
	54	variable	0,05	0,30	Centaur MT - REGULAR	NCS S2070-Y80R	NCS S1005-Y20R	1	
	55	variable	0,05	0,30	Centaur MT - REGULAR	NCS S2070-Y80R	NCS S1005-Y20R	1	
	56	-	-	-	-	-	-	0	
	57	variable	0,05	0,30	Centaur MT - REGULAR	NCS S2070-Y80R	NCS S5020-B	1	
	58	variable	0,05	0,30	Centaur MT - REGULAR	NCS S2070-Y80R	NCS S5020-B	1	
	59	variable	0,05	0,30	Centaur MT - REGULAR	NCS S2070-Y80R	TBD	1	
	60	variable	0,05	0,30	Centaur MT - REGULAR	NCS S2070-Y80R	TBD	1	
	61	variable	0,05	0,30	Centaur MT - REGULAR	NCS S2070-Y80R	NCS S7010-R70B	1	
62	-	-	-	-	-	-	0		
MODERN ART	63	variable	0,05	0,30	Town 80 Text (OTF) - BOLD	NCS S3060-R90B	NCS S2000-N	1	
	64	variable	0,05	0,30	Town 80 Text (OTF) - BOLD	NCS S3060-R90B	NCS S6500-N	1	
	65	variable	0,05	0,30	Town 80 Text (OTF) - BOLD	NCS S3060-R90B	NCS S4005-B20G	1	
ARCHITECTURE	66	variable	0,05	0,30	Auto 1 - BLACK	NCS S2005-Y	NCS S2000-N	1	
MODERN ART	67	variable	0,05	0,30	Town 80 Text (OTF) - BOLD	NCS S3060-R90B	NCS S2000-N	1	
	68	variable	0,05	0,30	Town 80 Text (OTF) - BOLD	NCS S3060-R90B	NCS S1510-Y20R	1	
	69	-	-	-	-	-	0		
	70	variable	0,05	0,30	Town 80 Text (OTF) - BOLD	NCS S3060-R90B	NCS S0500-N	1	
	71	variable	0,05	0,30	Town 80 Text (OTF) - BOLD	NCS S3060-R90B	NCS S0500-N	1	
	72	variable	0,05	0,30	Town 80 Text (OTF) - BOLD	NCS S3060-R90B	NCS S8010-R90B	1	
	73	variable	0,05	0,30	Town 80 Text (OTF) - BOLD	NCS S3060-R90B	NCS S2000-N	1	
	74	variable	0,05	0,30	Town 80 Text (OTF) - BOLD	NCS S3060-R90B	NCS S4050-Y70R	1	
CONTEMPORARY	75	variable	0,05	0,30	Museet Sans - LIGHT	NCS S 7502-B	NCS S0500-N	1	
	76	variable	0,05	0,30	Museet Sans - LIGHT	NCS S 7502-B	NCS S0500-N	1	
ARCHITECTURE	77	variable	0,05	0,30	Auto 1 - BLACK	NCS S2005-Y	NCS S2000-N	1	
	78	variable	0,05	0,30	Museet Sans - LIGHT	NCS S 7502-B	NCS S0500-N	1	
	79	-	-	-	Museet Sans - LIGHT	-	-	0	
	80	variable	0,05	0,30	Museet Sans - LIGHT	NCS S 7502-B	NCS S0500-N	1	
	81	variable	0,05	0,30	Museet Sans - LIGHT	NCS S 7502-B	NCS S0500-N	1	
	82	variable	0,05	0,30	Museet Sans - LIGHT	NCS S 7502-B	NCS S0500-N	1	

16.04 ROOM NUMBERS ON WALL

Section	Room	Width (m)	Depth (m)	Height (m)	Font	Side colour	Front colour	Quantity (item)	NOTE
CONTEMPORARY	83	variable	0,05	0,30	Museet Sans - LIGHT	NCS S 7502-B	NCS S0500-N	1	
	84	variable	0,05	0,30	Museet Sans - LIGHT	NCS S 7502-B	NCS S0500-N	1	
	85	variable	0,05	0,30	Museet Sans - LIGHT	NCS S 7502-B	NCS S0500-N	1	
	86	variable	0,05	0,30	Museet Sans - LIGHT	NCS S 7502-B	NCS S0500-N	1	
	87	variable	0,05	0,30	Museet Sans - LIGHT	NCS S 7502-B	NCS S0500-N	1	
	88	variable	0,05	0,30	Museet Sans - LIGHT	NCS S 7502-B	NCS S0500-N	1	
	89	variable	0,05	0,30	Museet Sans - LIGHT	NCS S 7502-B	NCS S0500-N	1	
TOTAL								82	

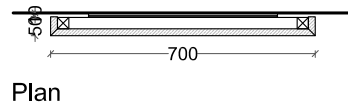
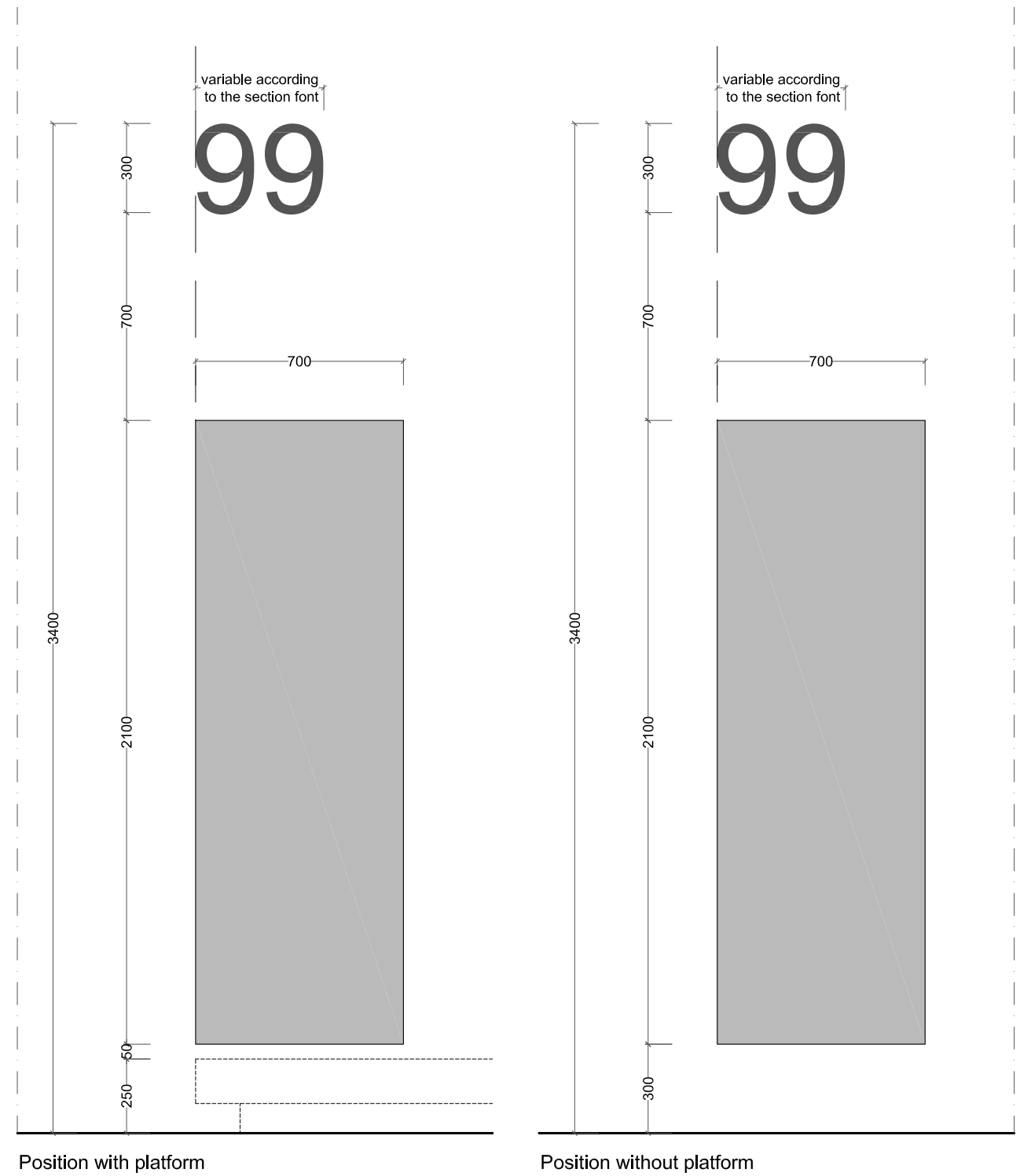
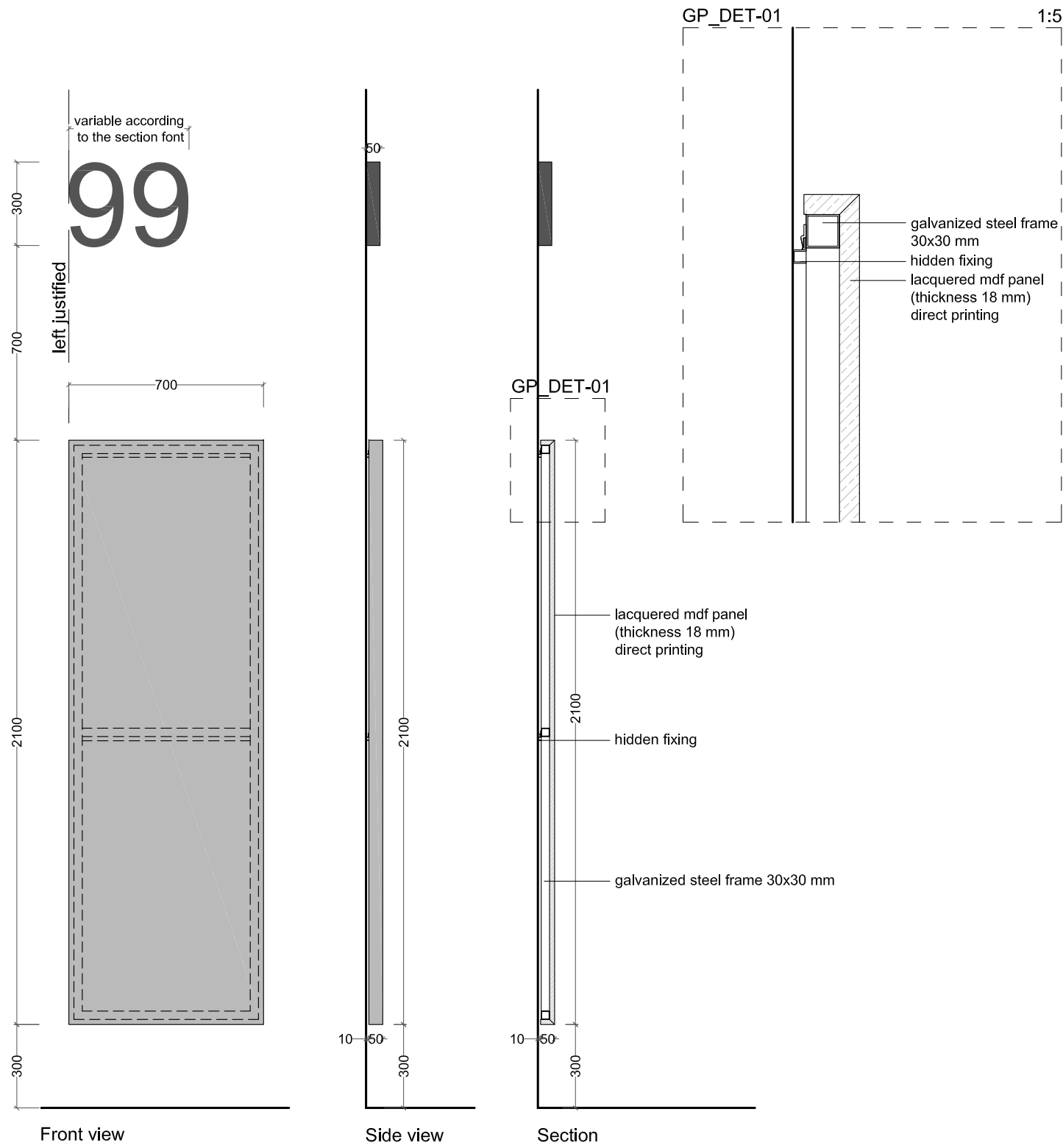

PANELS

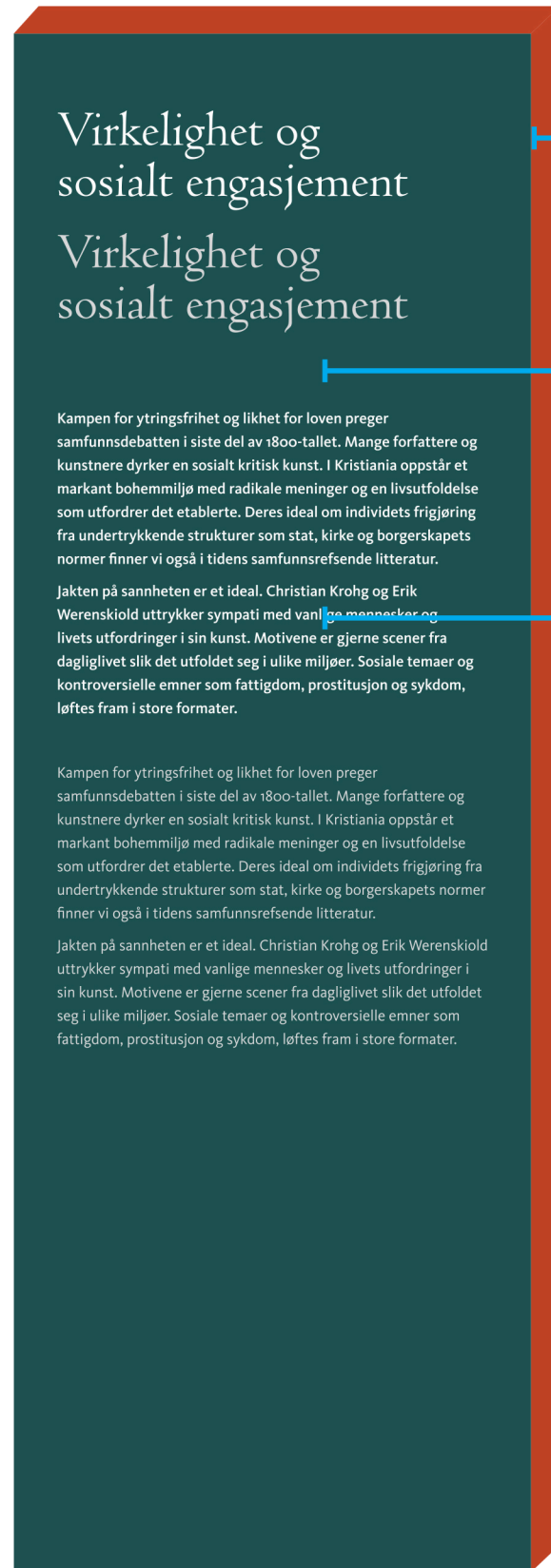
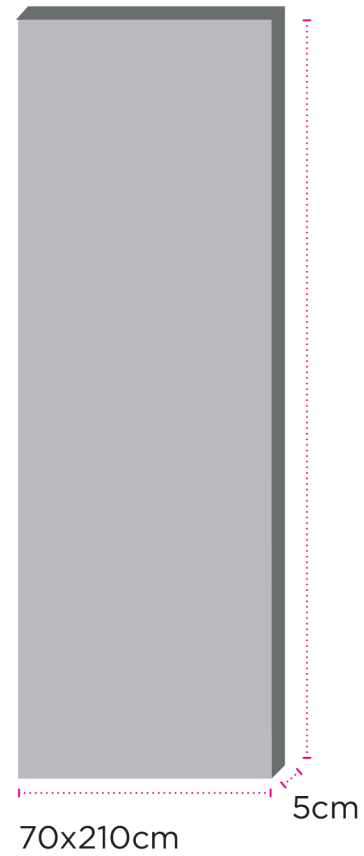

lacquered edges in the colour of the museum section

lacquered surface: rooms 1+31 all in the same colour
rooms 33-74 each panel in the colour of the room

Text: direct print

SECTION COLOURS

ANTIQUITY AND DECORATIVE ARTS
NCS S2030-B10G
ROOMS: 1-18

FASHION, STUDIO CRAFTS AND DESIGN
NCS S1075-G90Y
ROOMS: 19-31

KUNST/ART 1500-1900
NCS S2070-Y80R
ROOMS: 33-61

KUNST/ART 1900-1970
NCS S 3060-R90B
ROOMS: 63-76

ARCHITECTURE
NCS S 2005-Y
ROOMS: 66 + 77

KUNST/ART 1970-TODAY
NCS S 7502-B
ROOMS: 78-88

ANTIQUITY AND DECORATIVE ARTS ROOMS 1-18

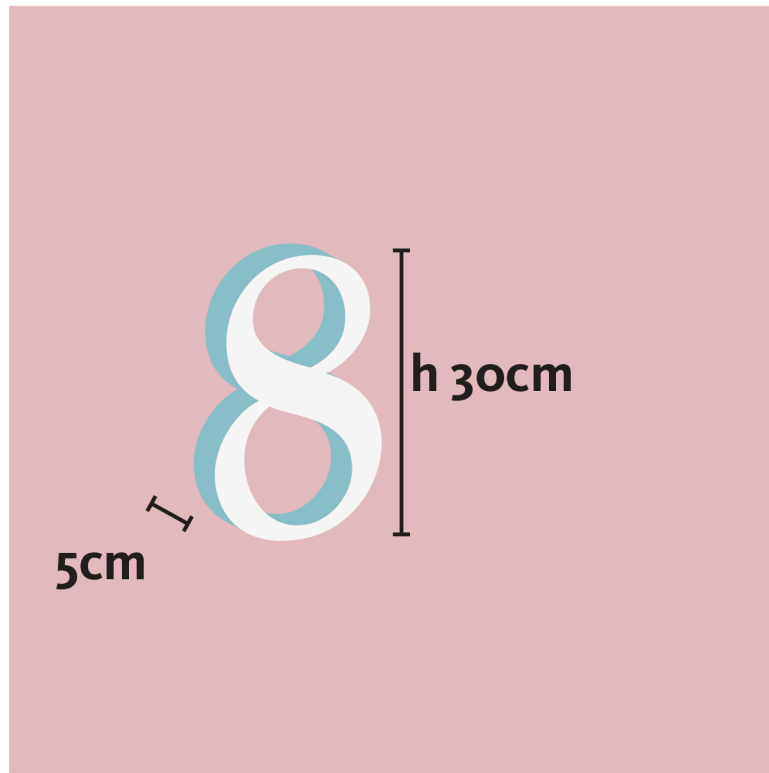

WALL COLOUR
NCS S2020-R

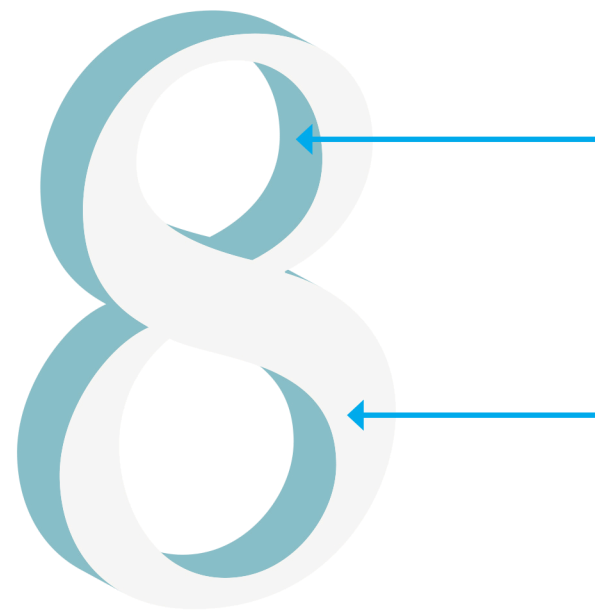

SIDE COLOUR
NCS S2030-B10G

FRONT COLOUR
NCS S 1500N

FONT
Goudy - Bold Oldstyle Figures



SCALA 1:4

FASHION, STUDIO CRAFTS AND DESIGN
ROOMS 19-31

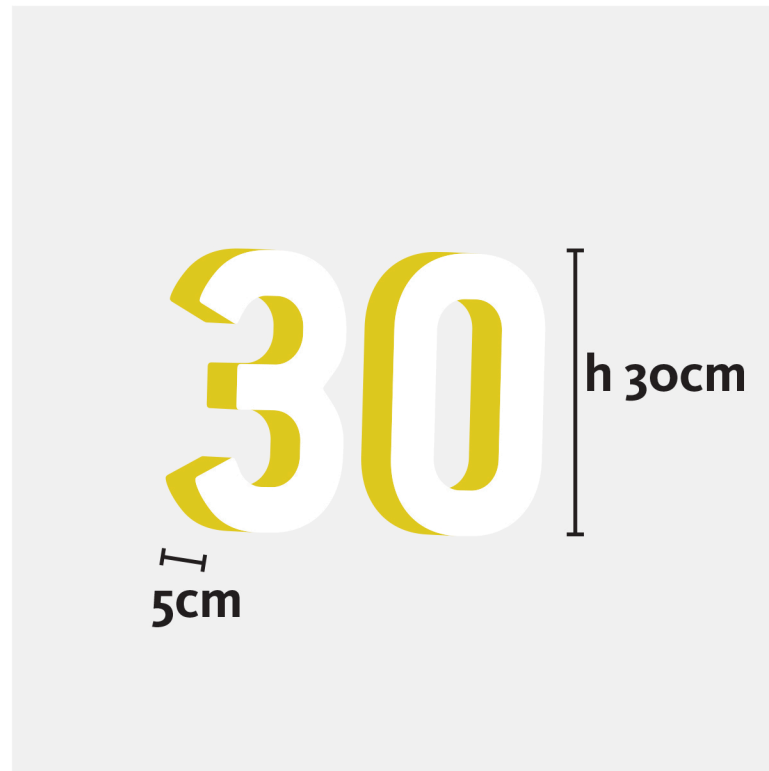

WALL COLOUR
NCS S2502-B

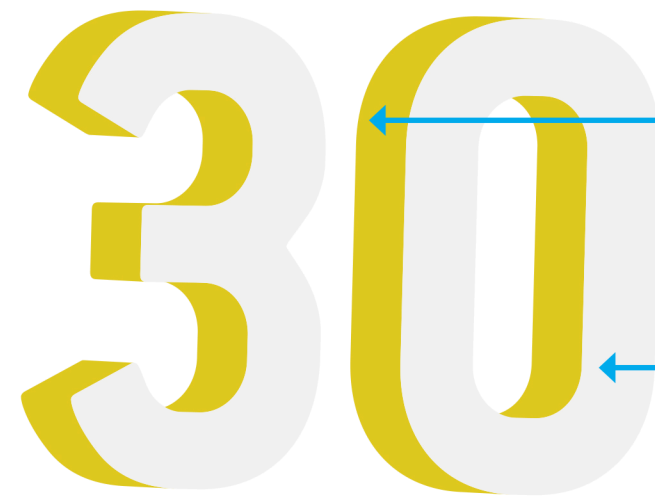

SIDE COLOUR
NCS S1075-G90Y

FRONT COLOUR
NCS S 1500N

FONT
Conduit ITC - BOLD

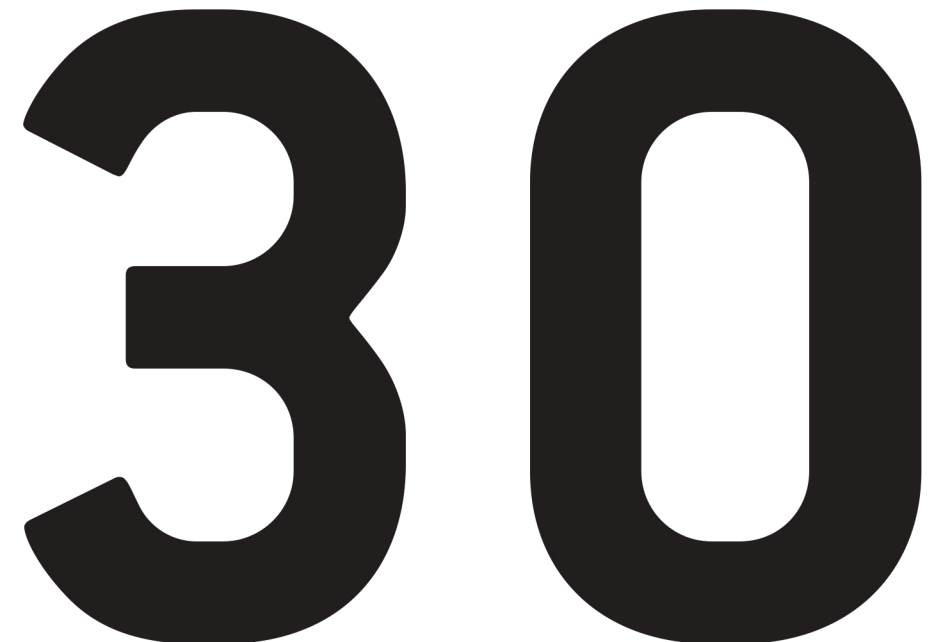

KUNST ART 1500-1900
ROOMS 33-61

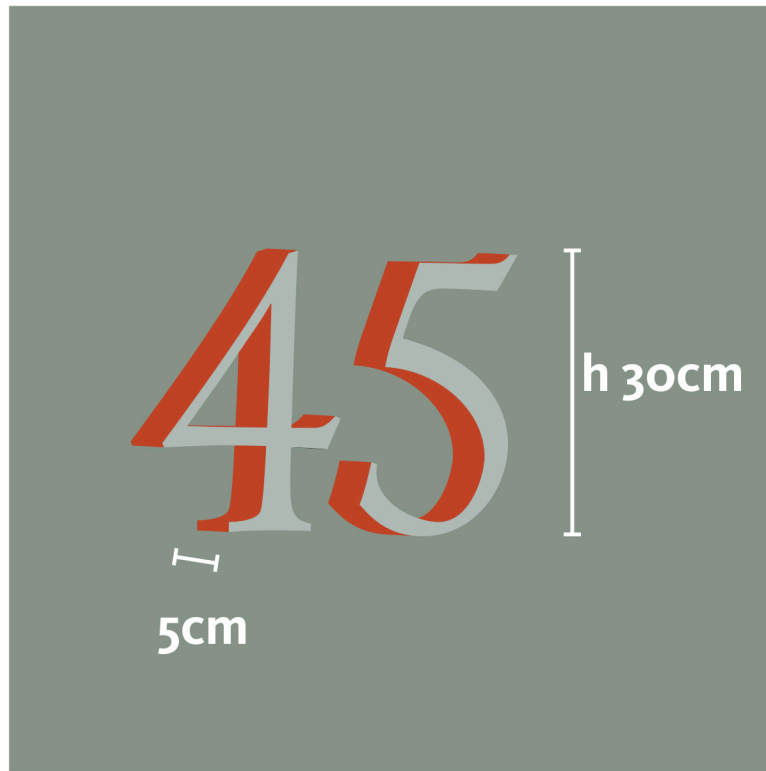

WALL COLOUR
NCS S4010-G10Y



FONT
Centaur MT - REGULAR



KUNST ART 1900-1970
ROOMS 63-74

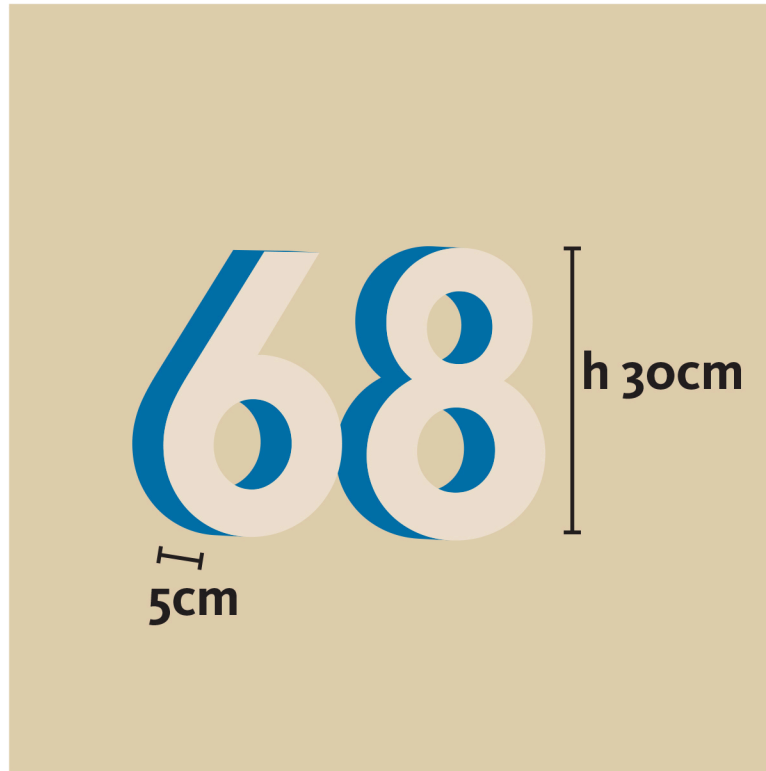

WALL COLOUR
NCS S1510-Y20R

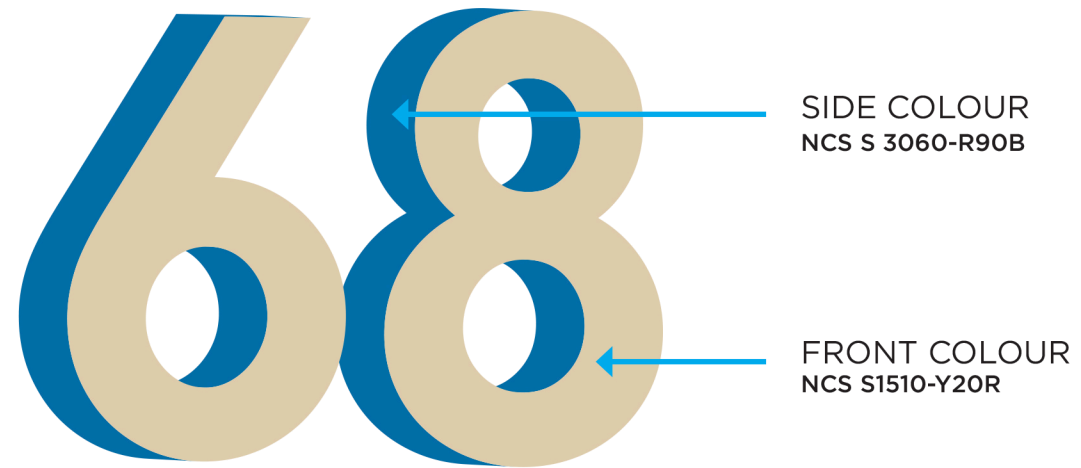

FONT
Town 80 Text (OTF) - BOLD

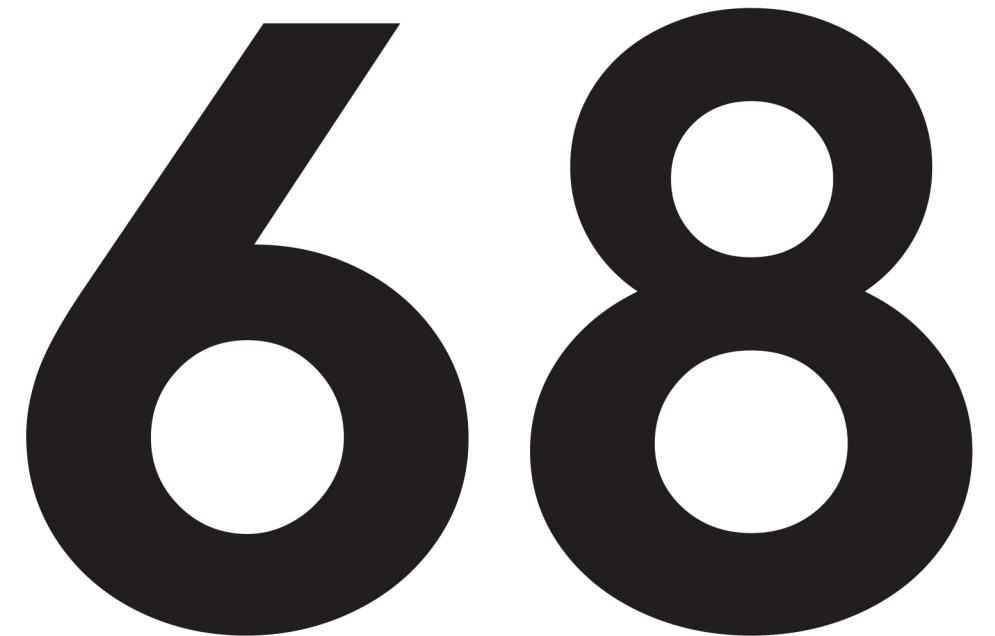

ARCHITECTURE
ROOMS 66 and 77

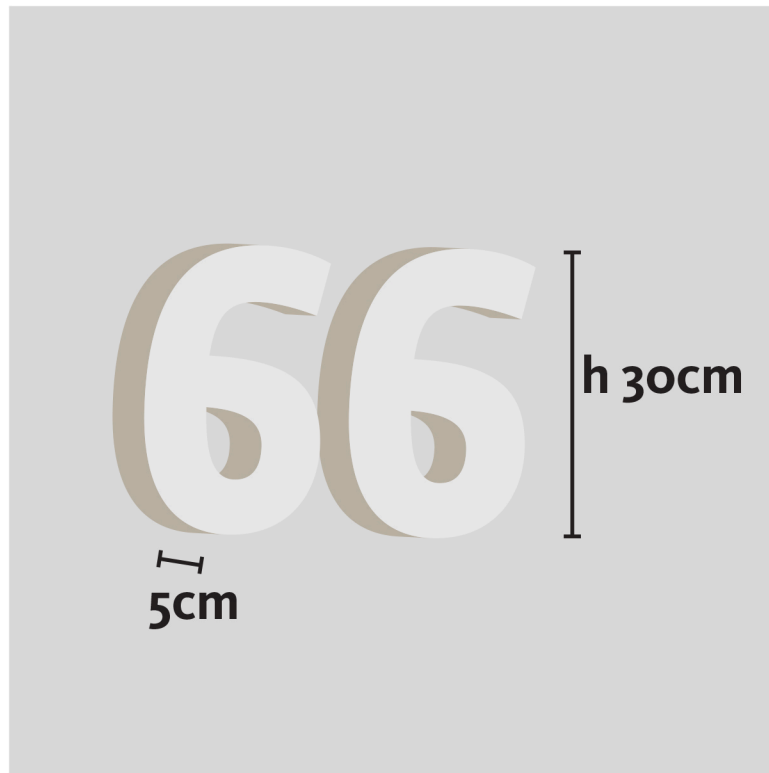

WALL COLOUR
NCS S2000-N

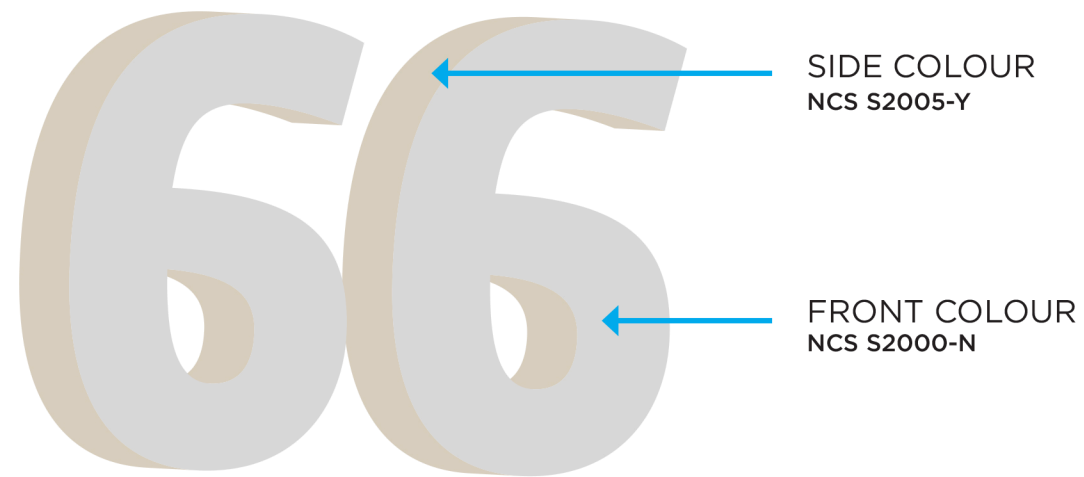

FONT
Auto 1 - BLACK



KUNST ART 1970-TODAY
ROOMS 75-88

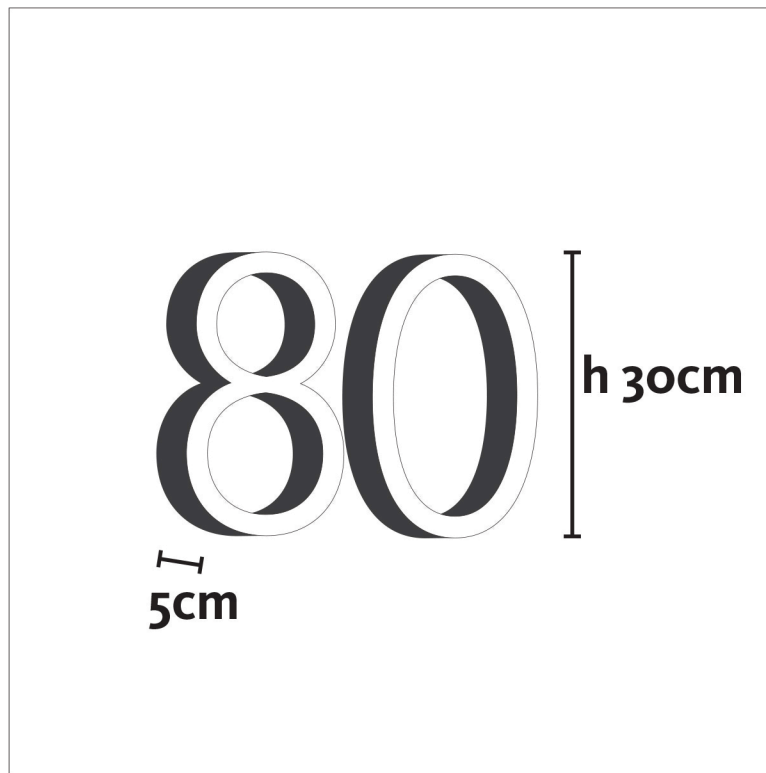

WALL COLOUR
NCS S0500-N

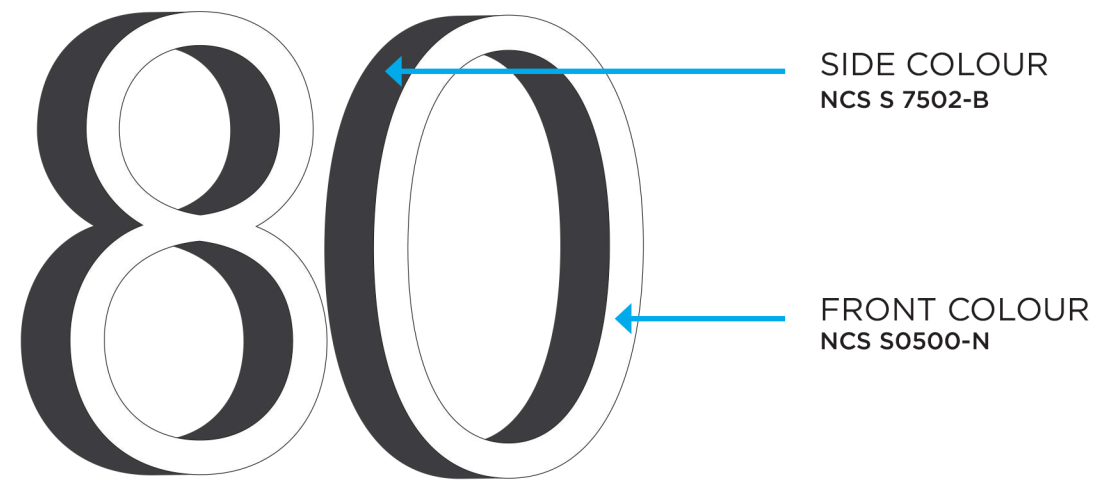

FONT
Museet Sans - LIGHT



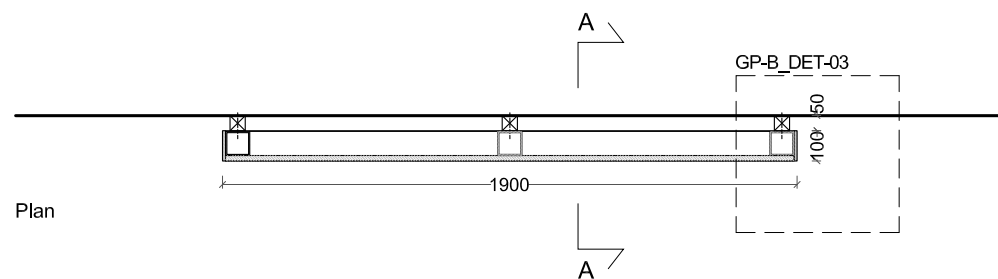
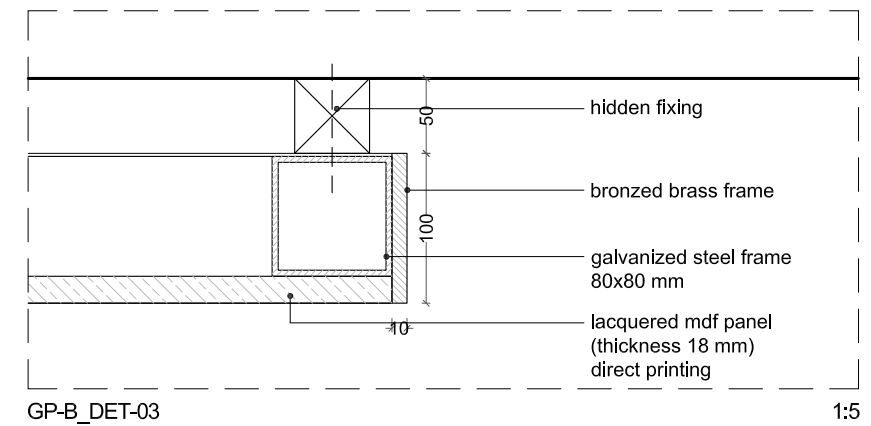
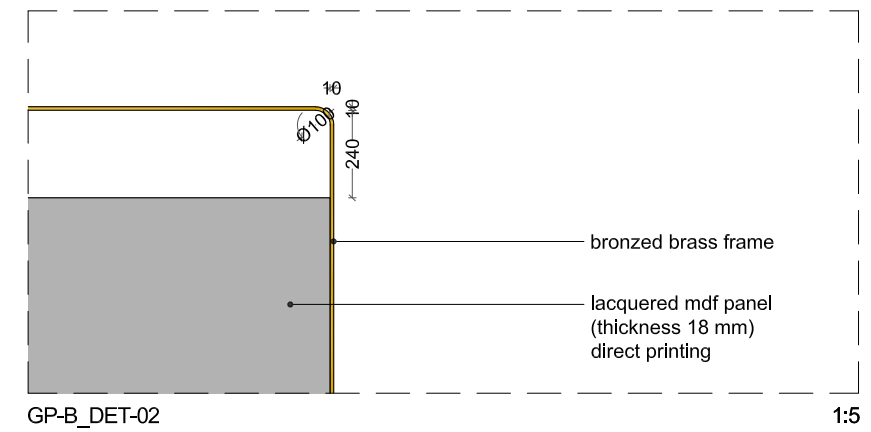
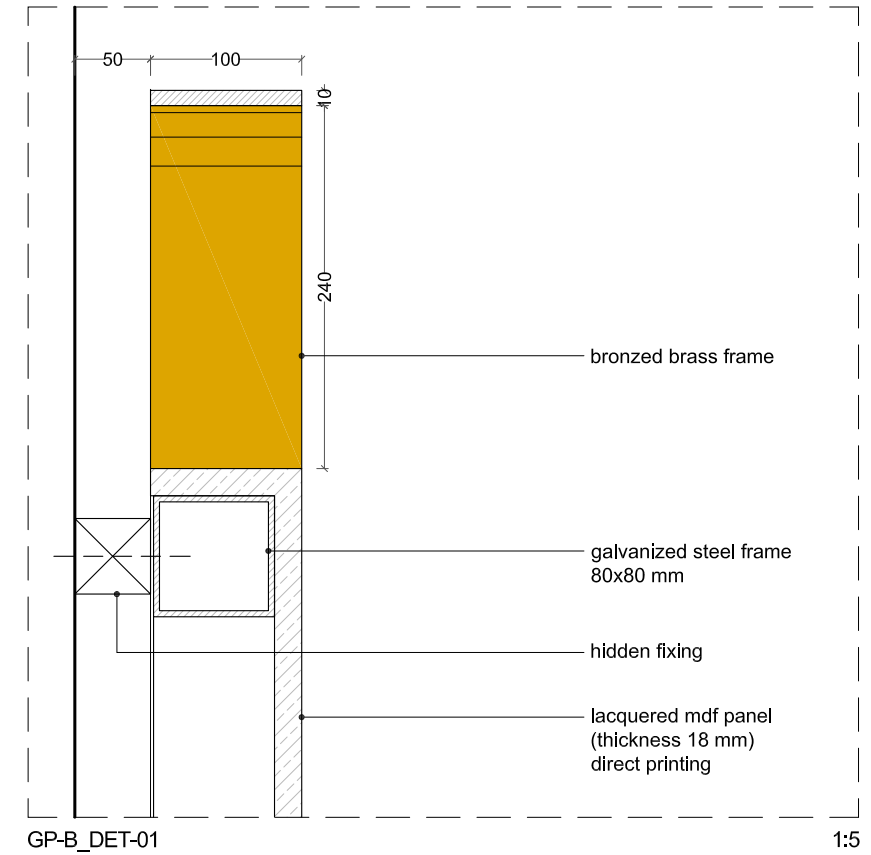
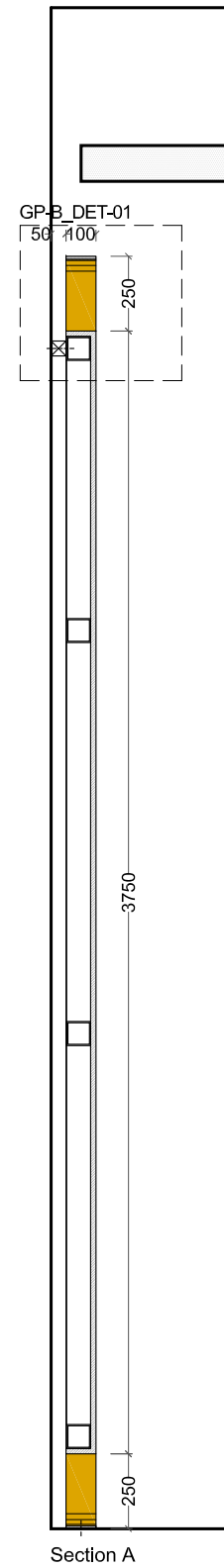
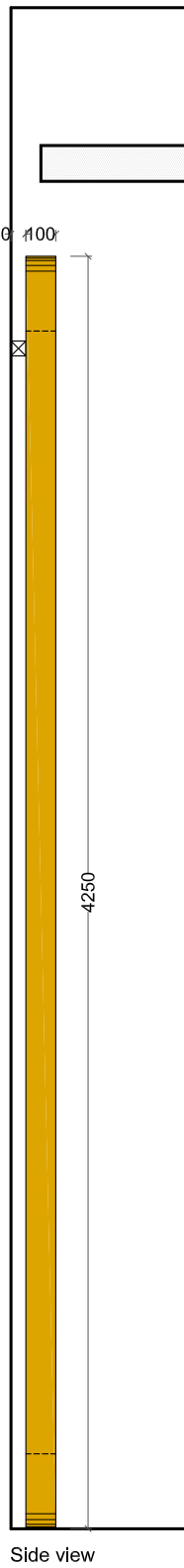
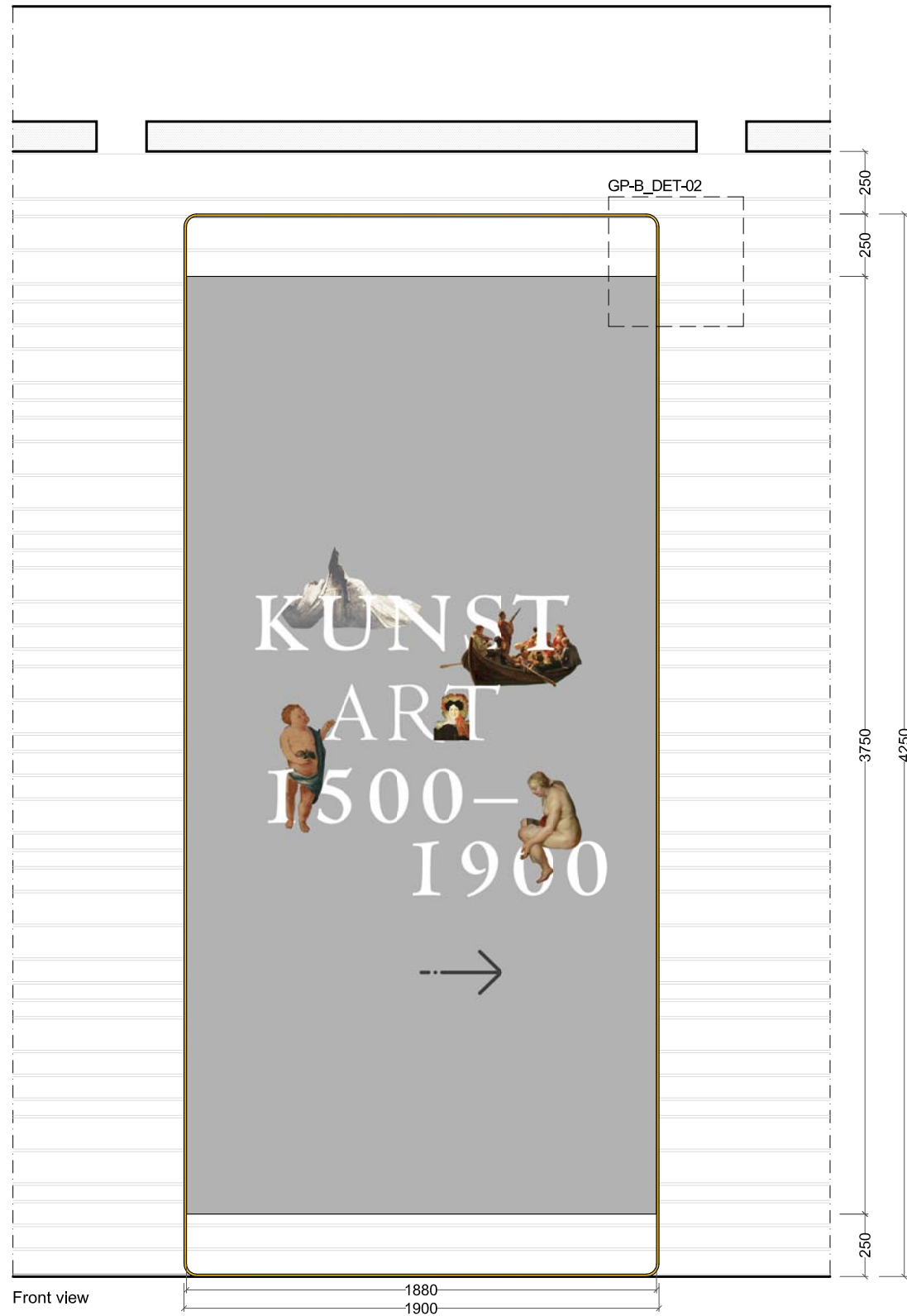

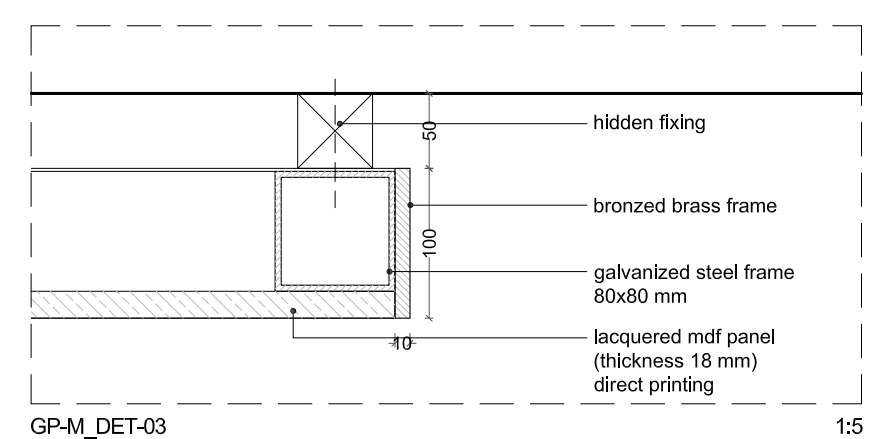
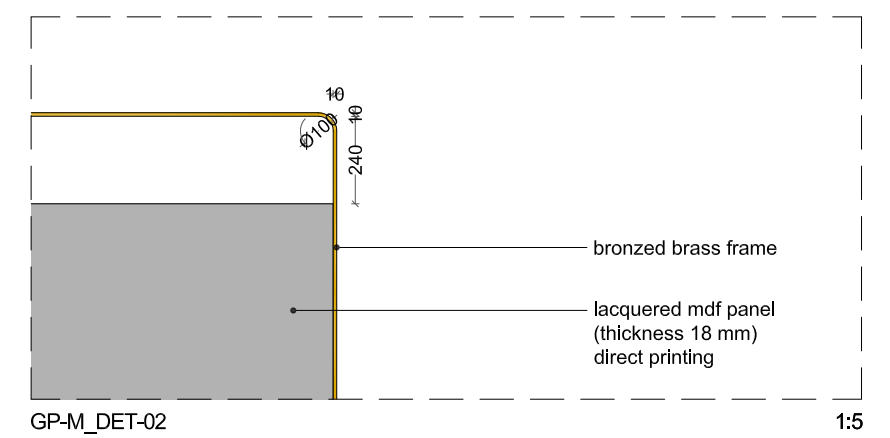
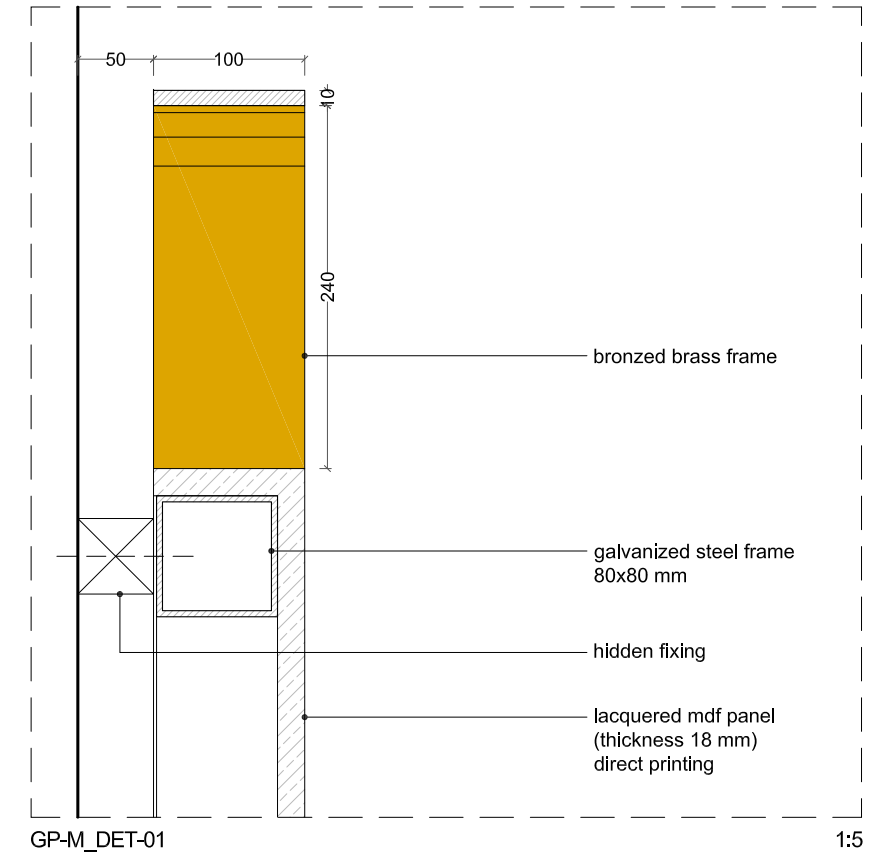
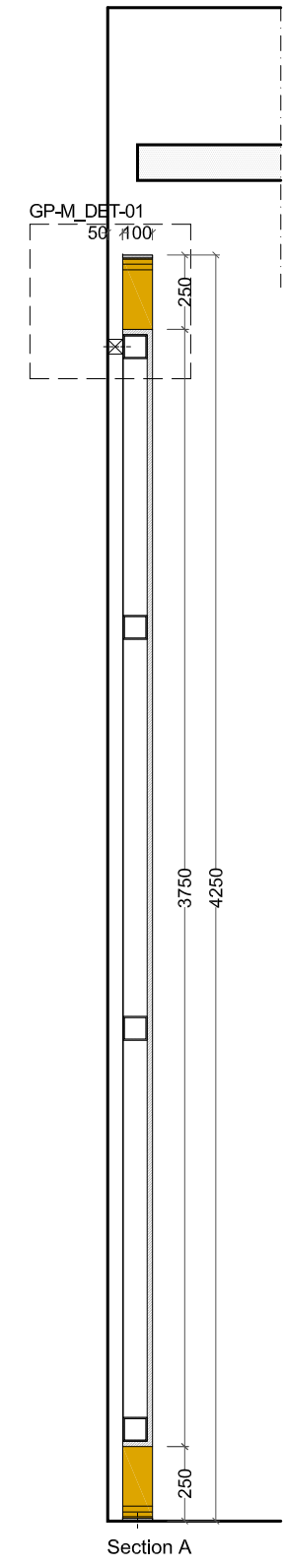
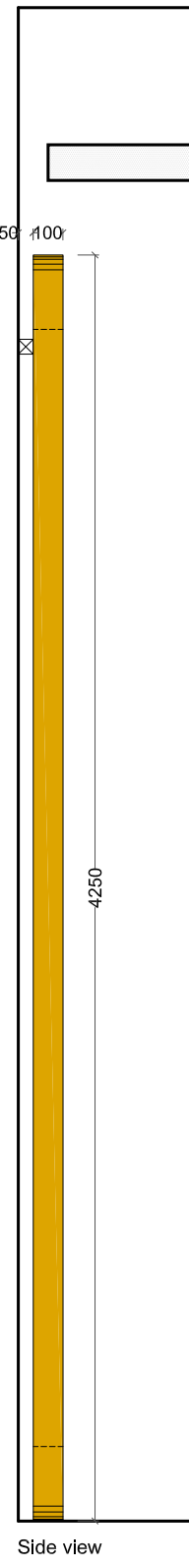
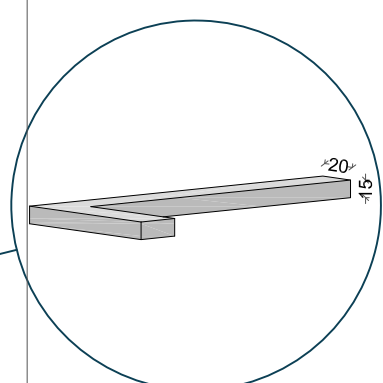
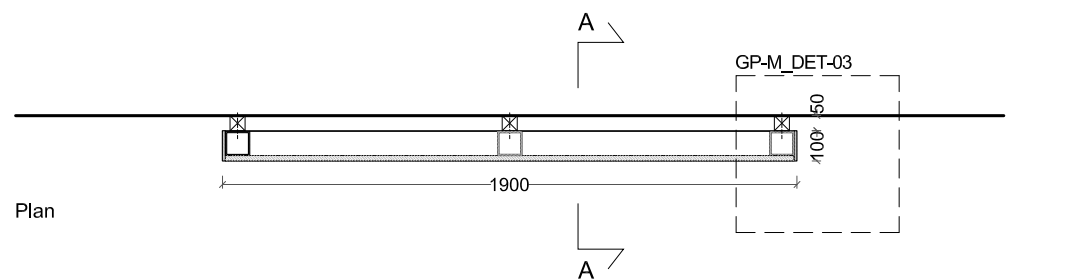
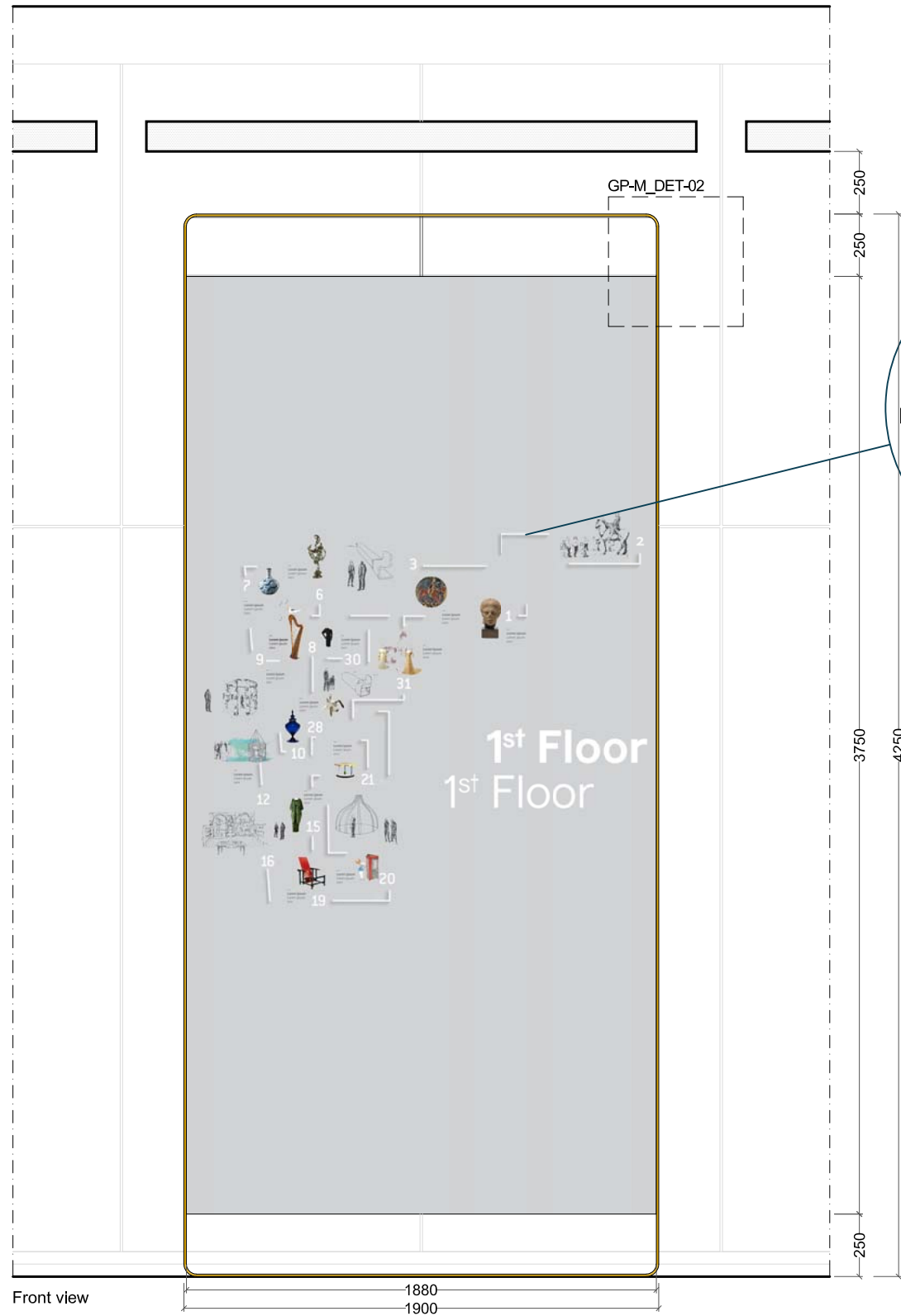

Bronzed brass

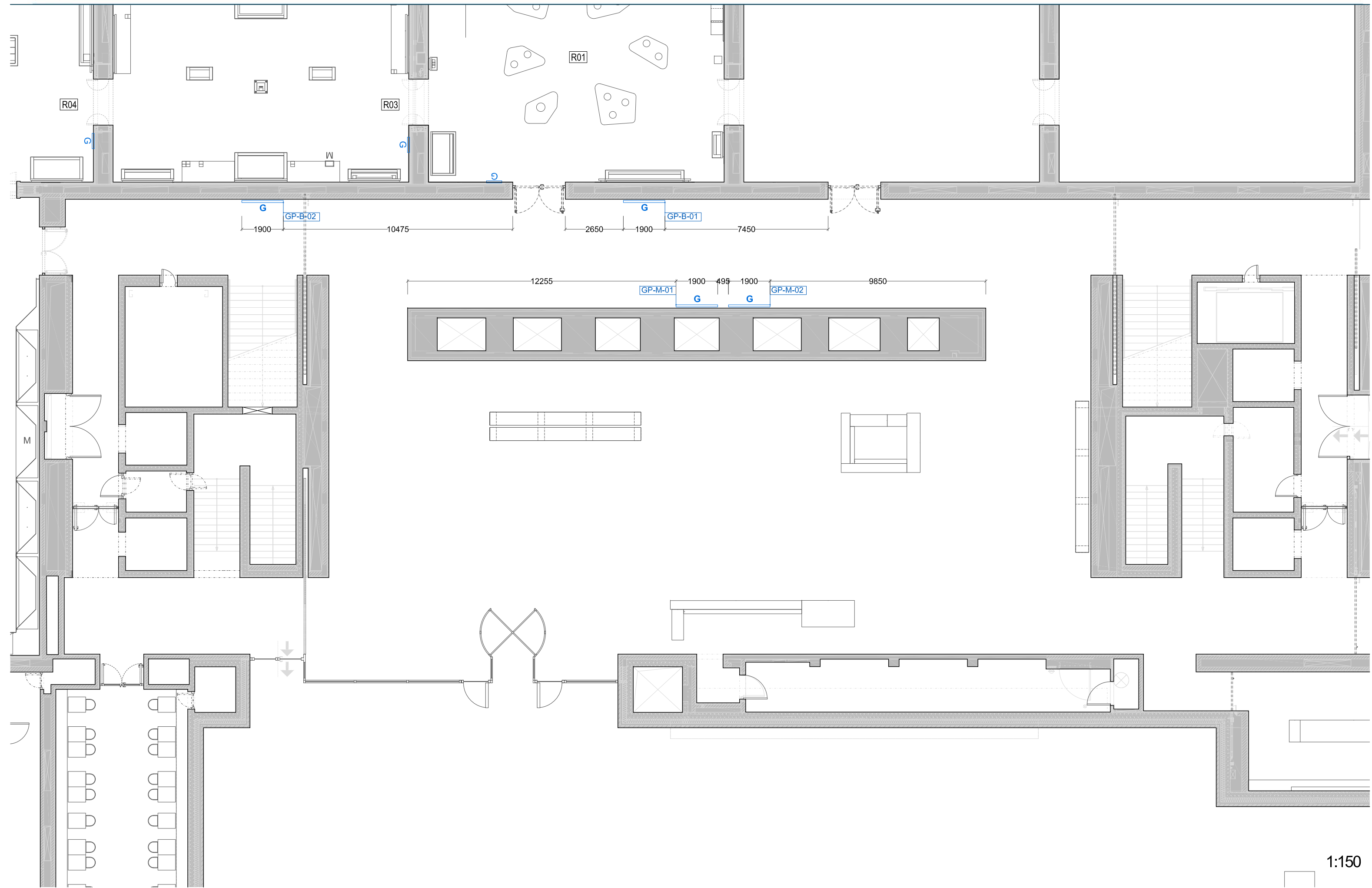

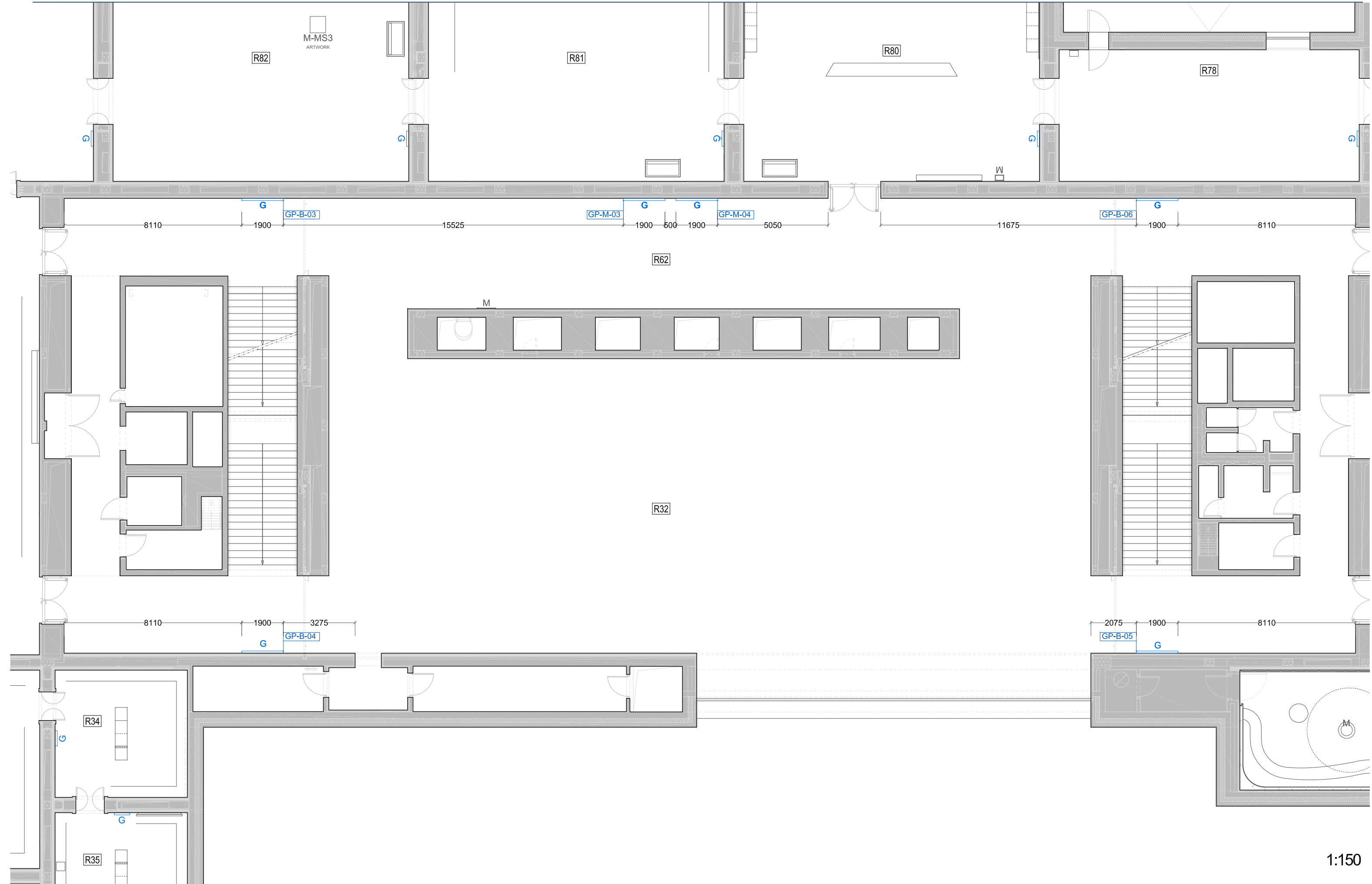

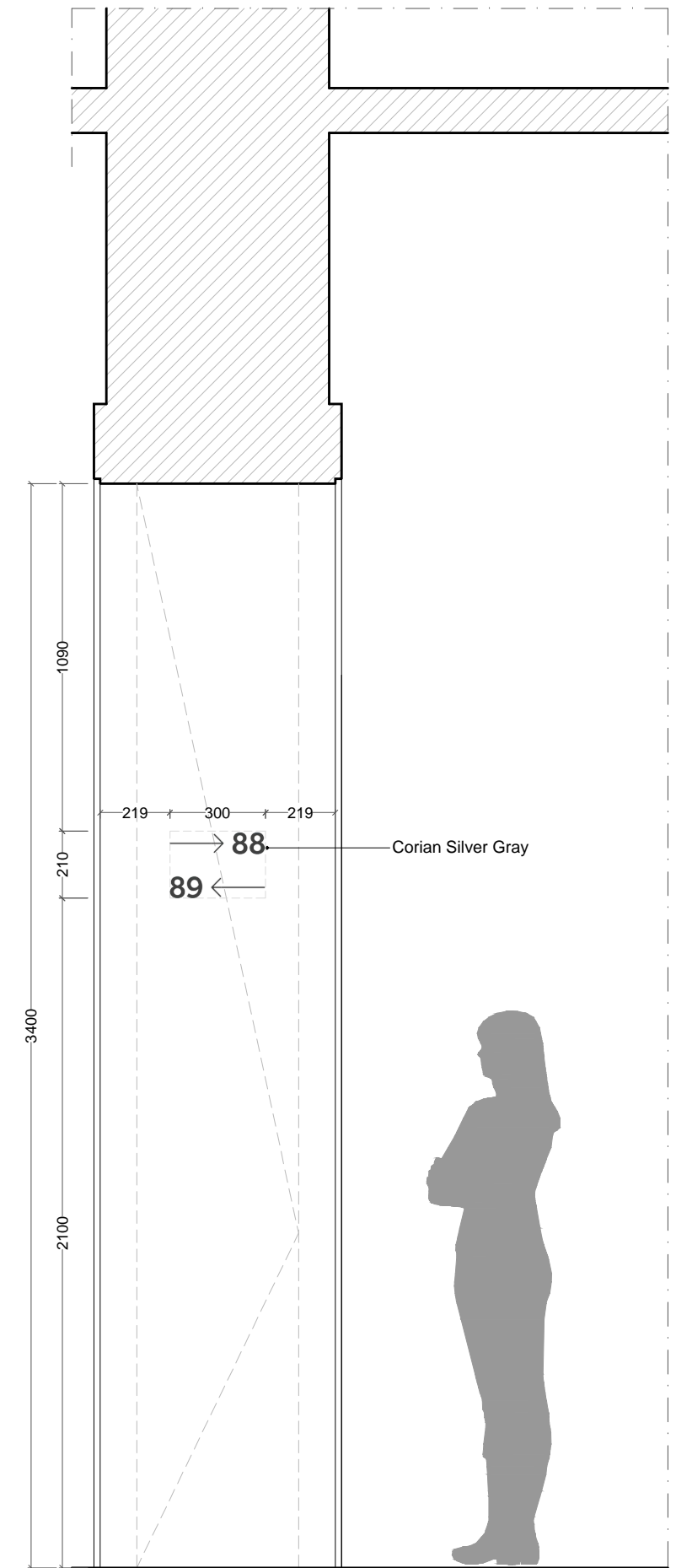
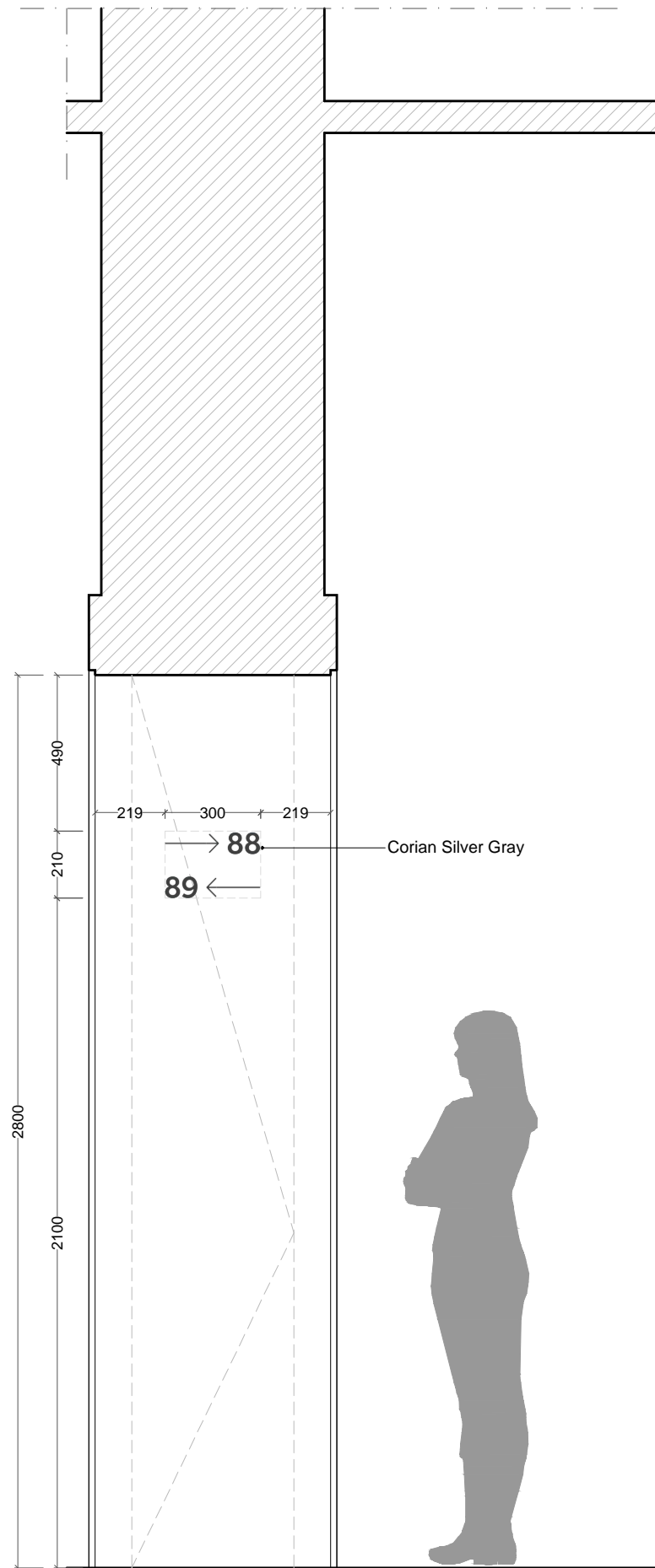
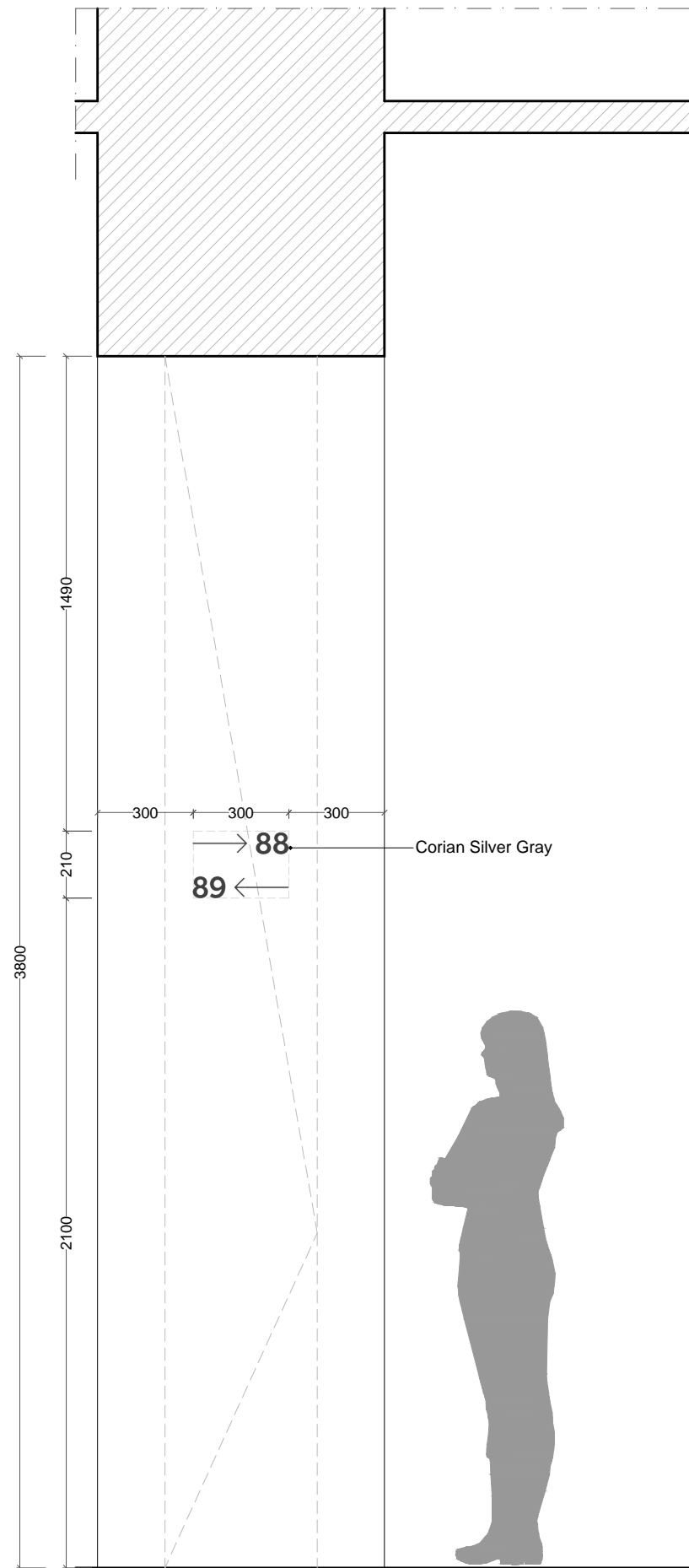

Single element

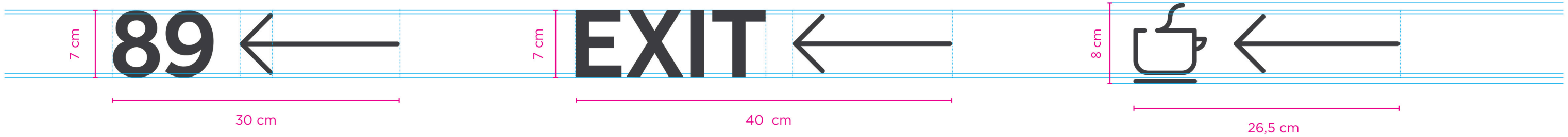

Double elements

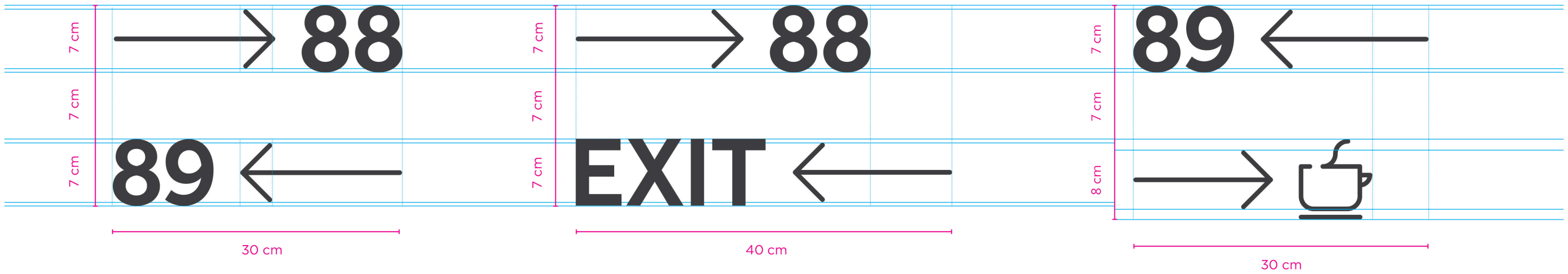

Mixed combinations

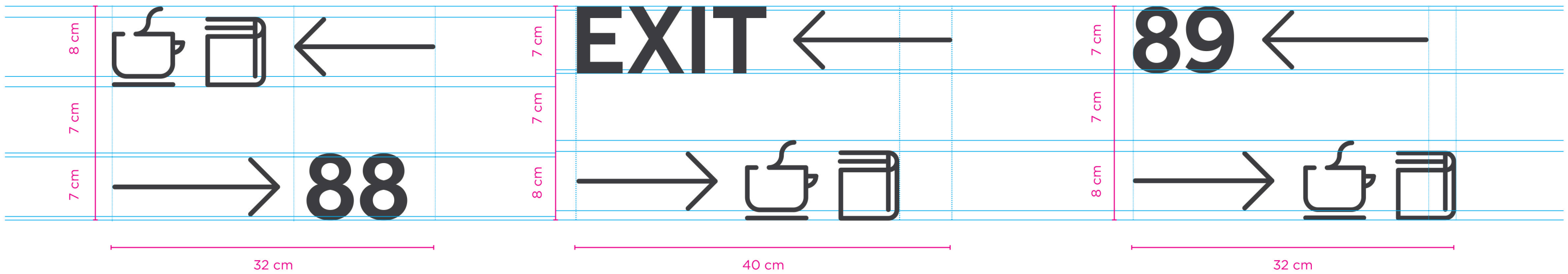



Aluminium sheet direct printing thickness 1mm (context photos size A4) to hang over the panels

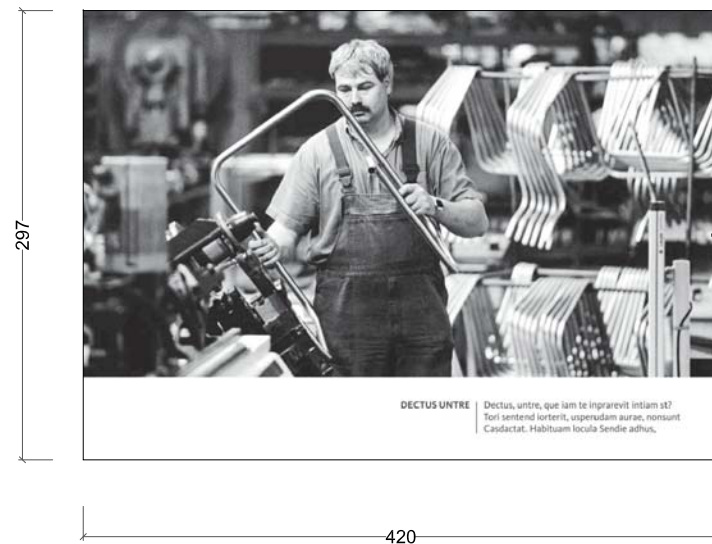

Aluminium sheet direct printing thickness 1mm (context photos size A3) to hang over the panels



16.05 LABEL HOLDERS (LH)

Colour	Room	LH_T1					LH_T2					LH_T3					LH_T4						LH_T5			Note		
		H260 L180	H260 L360	H260 L540	H260 L720	H260 L900	H130 L180	H130 L360	H130 L540	H130 L720	H130 L900	H130 L180	H130 L360	H260 L180	H130 L540	H260 L360	H390 L180	H180 L180	H180 L1400	H180 L1900	H180 L3670	H180 L5000	H180 L6000	H180 L6500	H130 L180		H130 L360	H130 L900
NCS S 7502-B	83											1																
	84											22																
	85											20																
	86											19																
	87											3																
	88											18																
	89											1																
to be defined	Extra	1278		10	10	10		10	10		10	821			10	10	10											
TOTAL		1420	2	10	10	10	53	10	10	3	10	1642	6	3	10	10	10	2	2	8	1	1	2	1	2	1	3	
		255,6	0,72	5,4	7,2	9	9,54	3,6	5,4	2,16	9	296	2,16	0,54	5,4	3,6	1,8	4,88						3,42				
		ml	ml	ml	ml	ml	ml	ml	ml	ml	ml	ml	ml	ml	ml	ml	ml	ml						ml				

LH_T1-H260L180

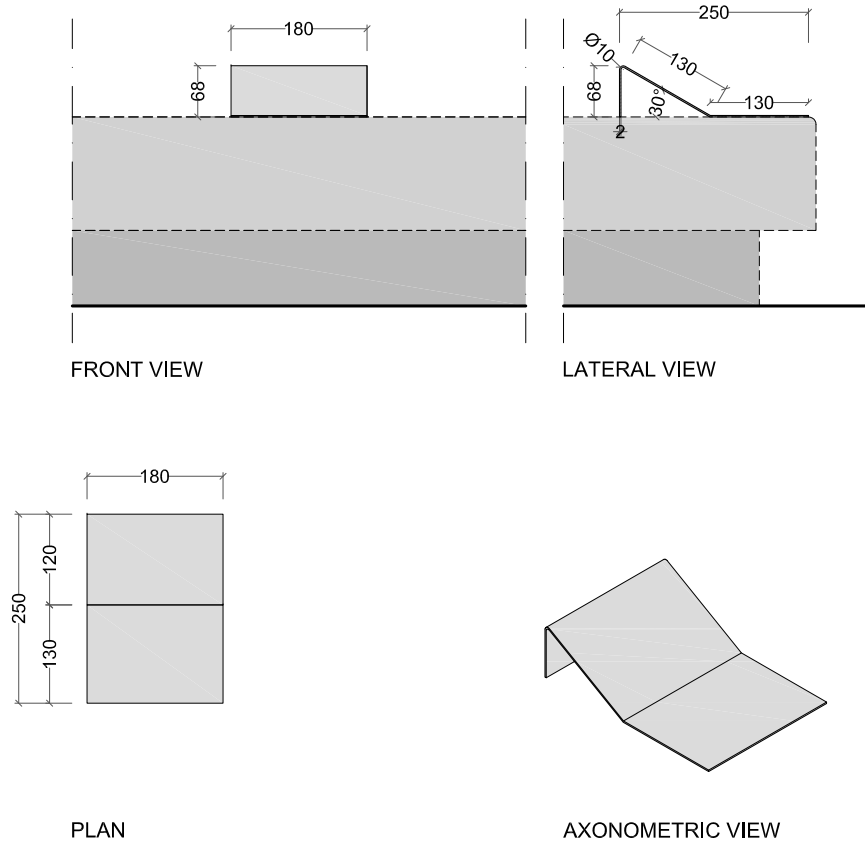

LH_T1-H260L360

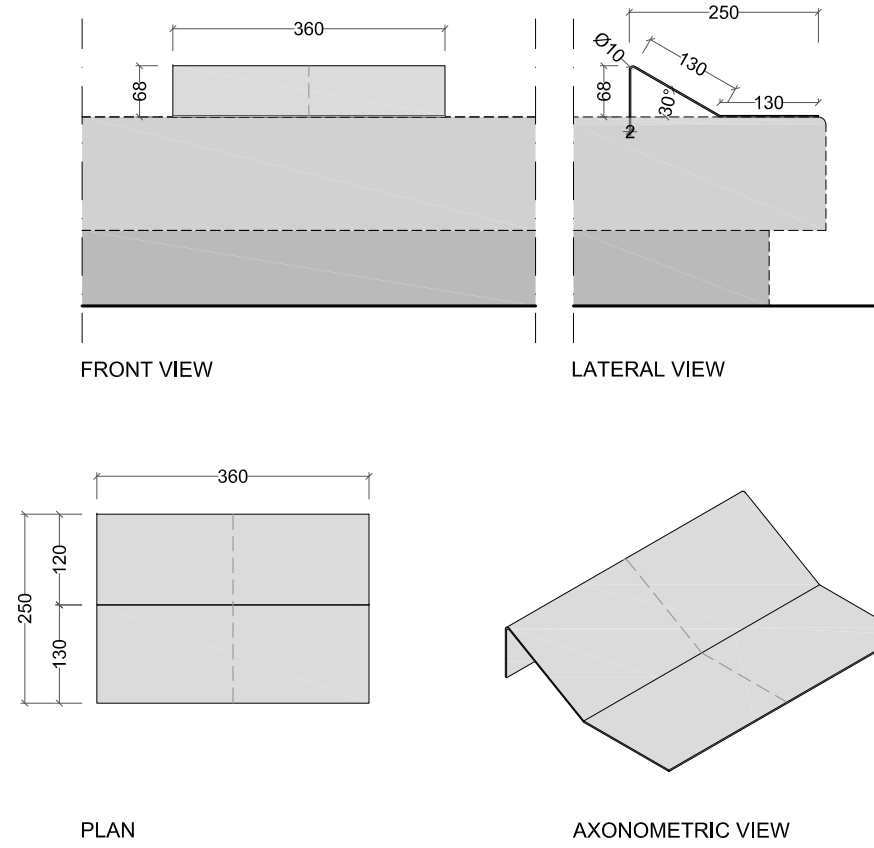

LH_T1-H260L540

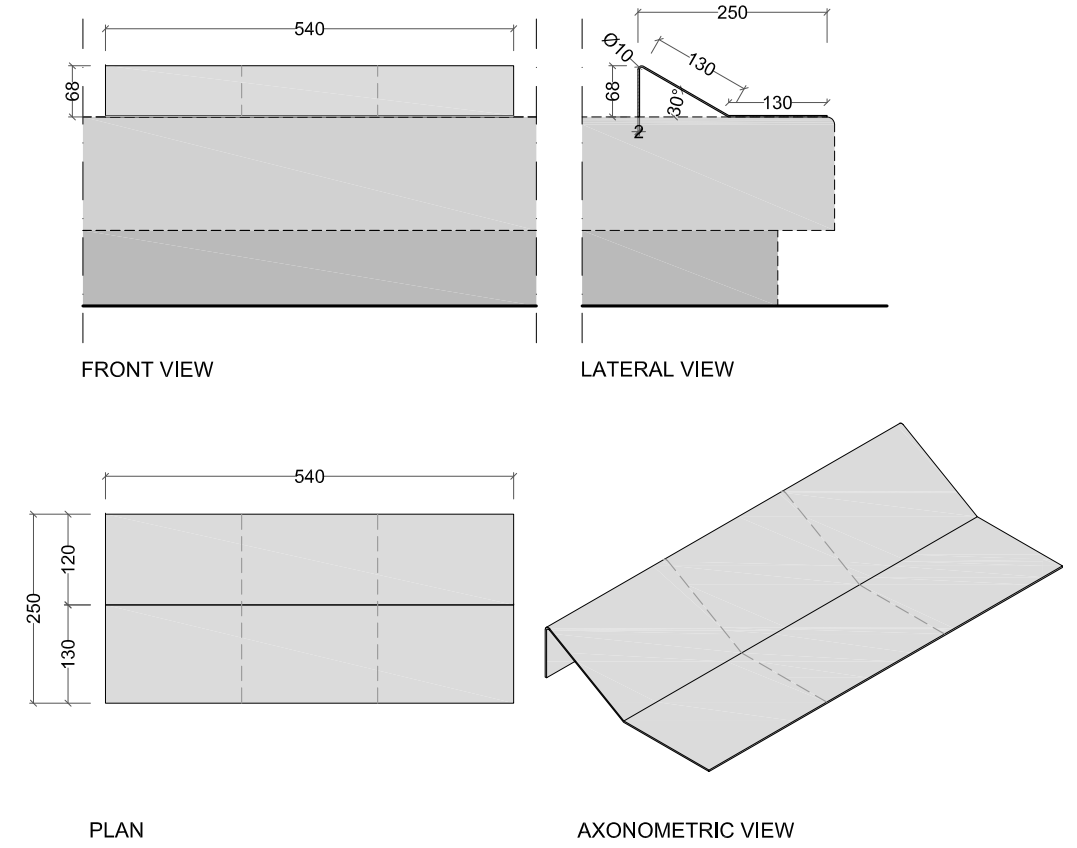

LH_T1-H260L720

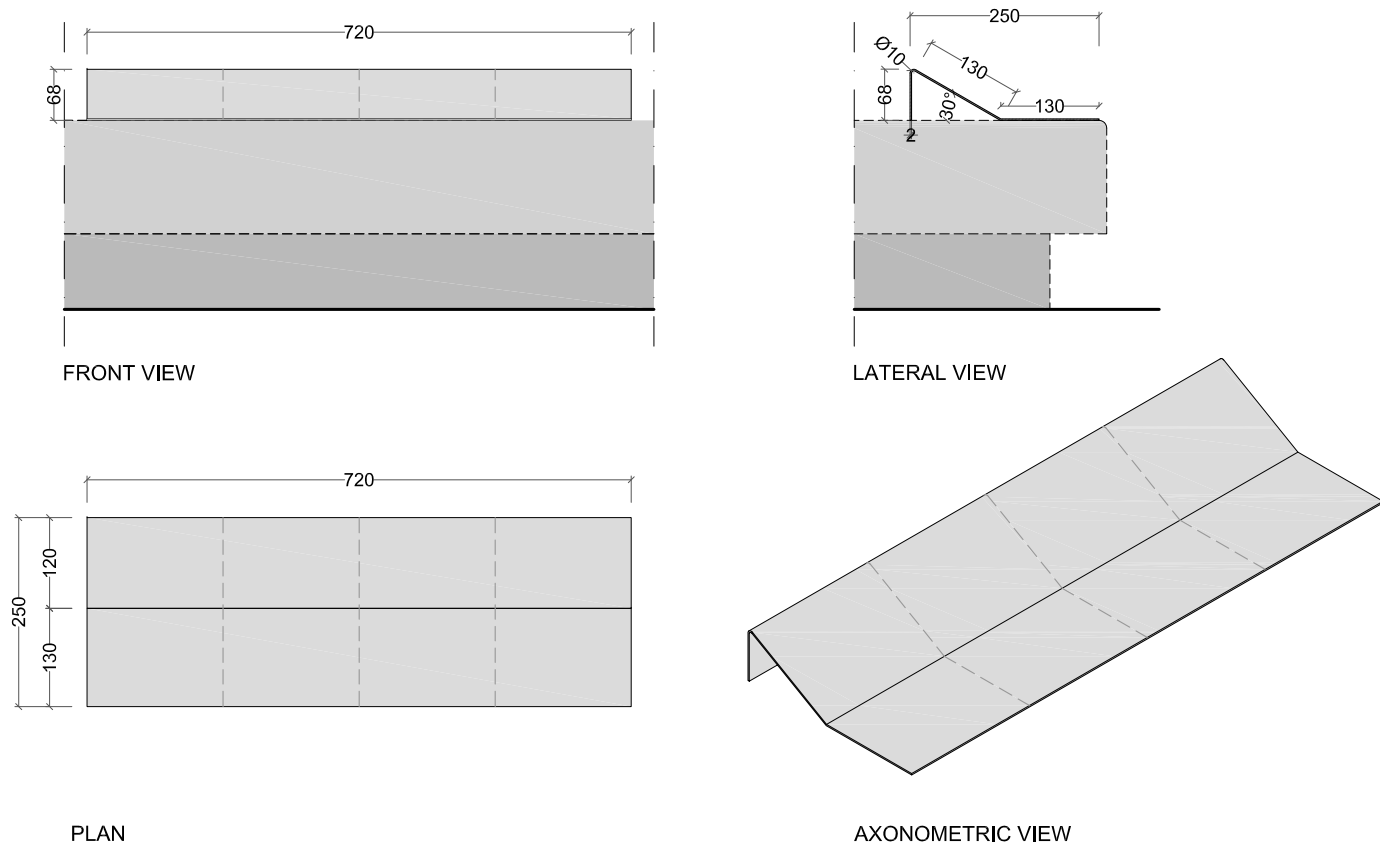

LH_T1-H260L900

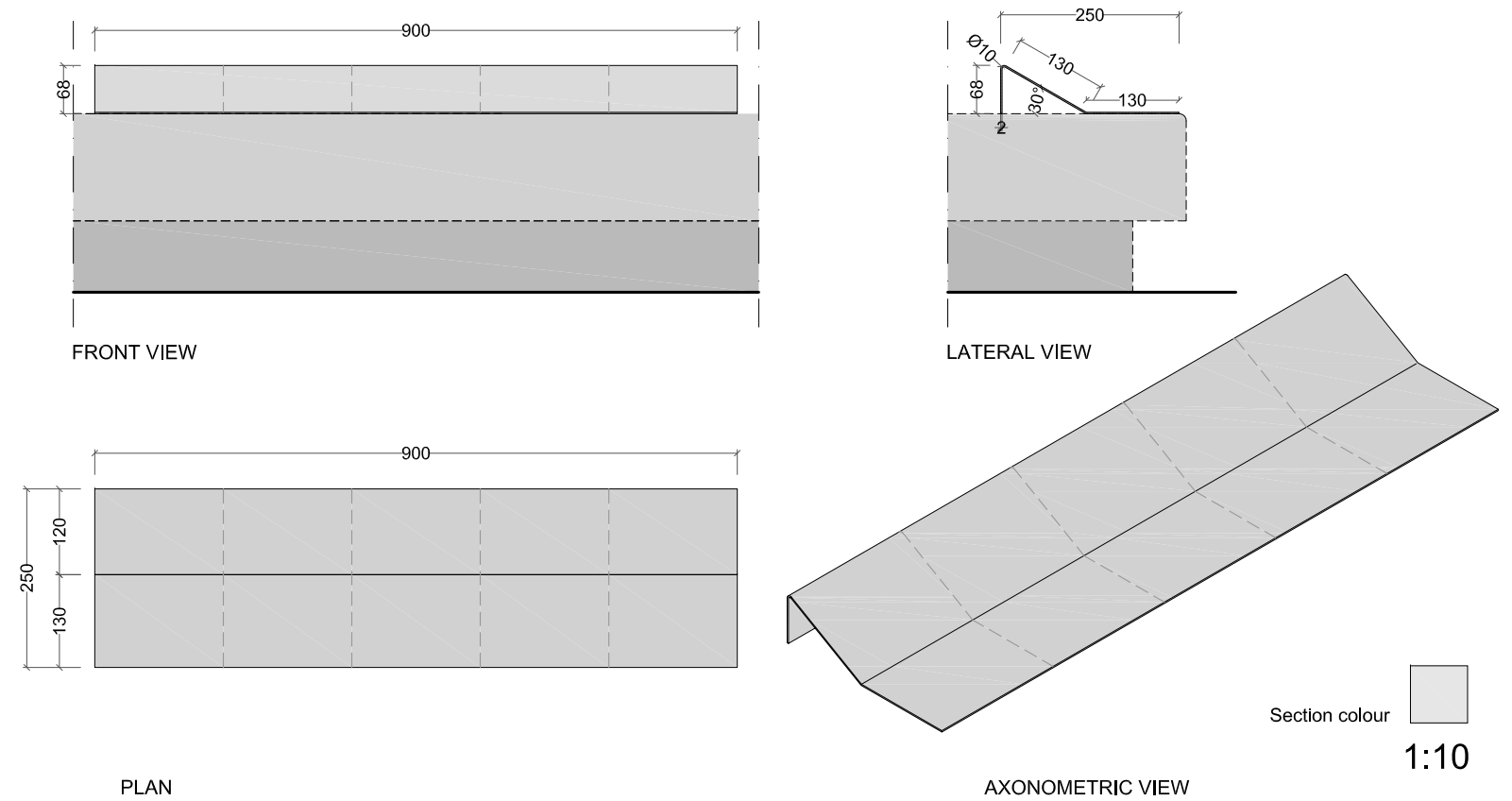

Section colour

1:10

LH_T2-H130L180

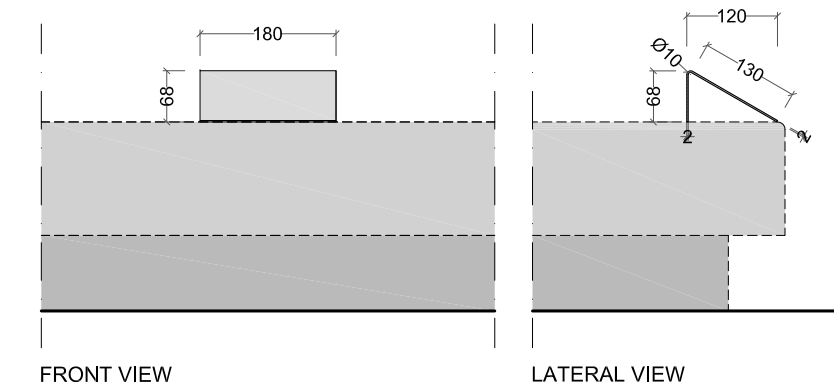

LH_T2-H130L360

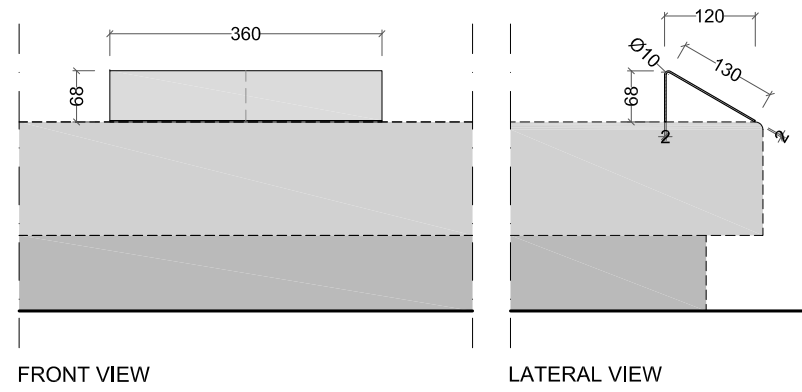

LH_T2-H130L540

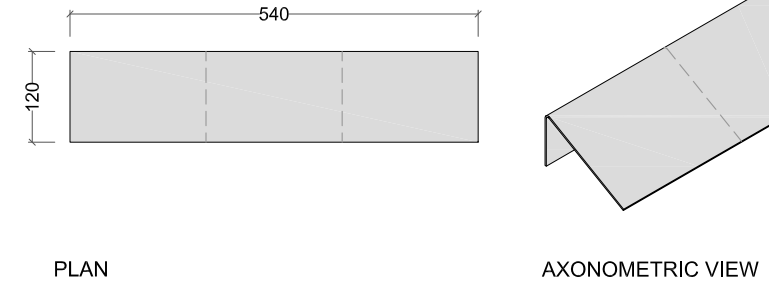
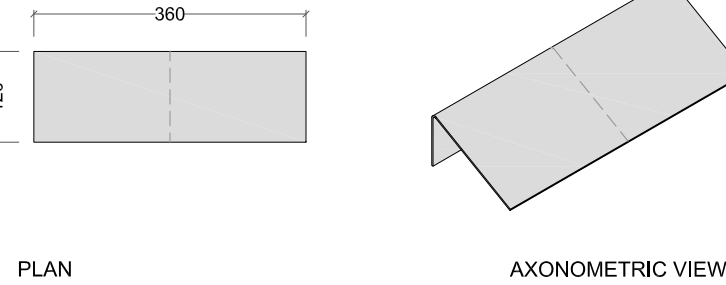
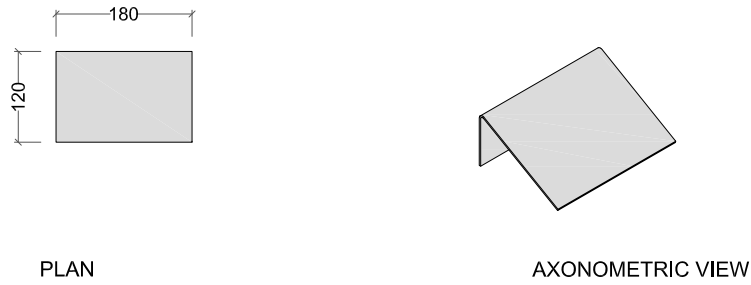
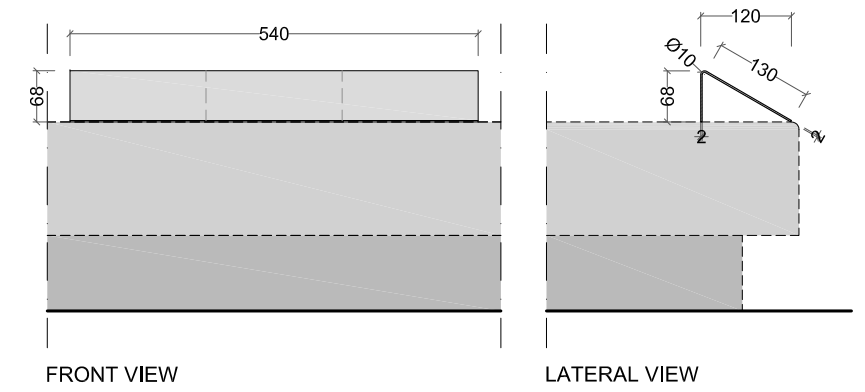

LH_T2-H130L720

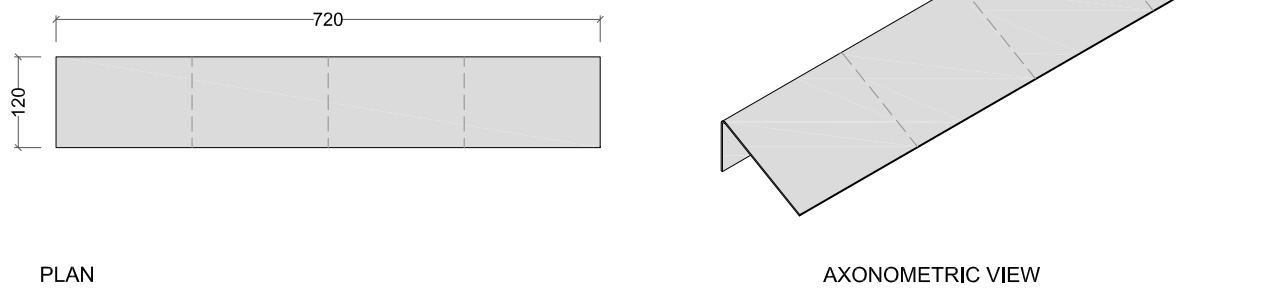
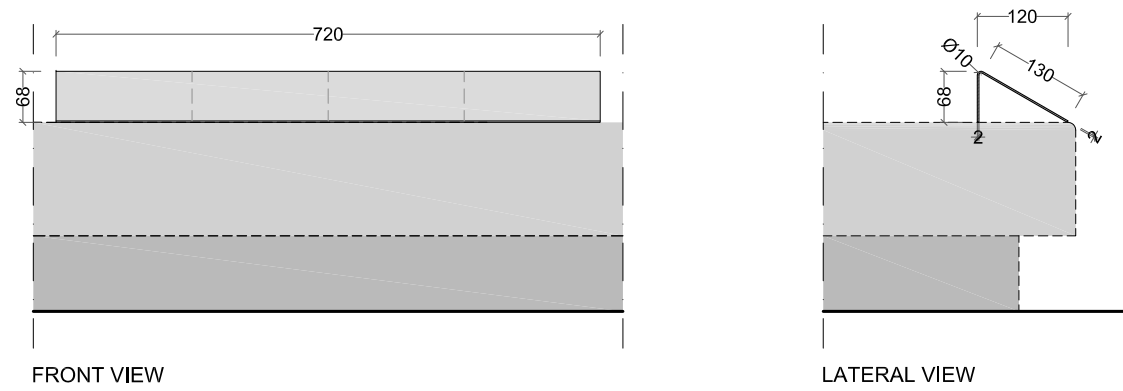

LH_T2-H130L900

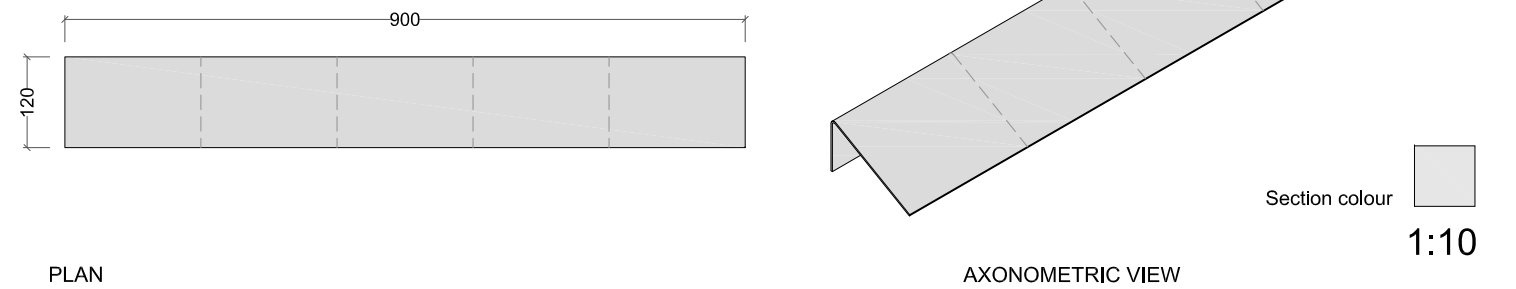
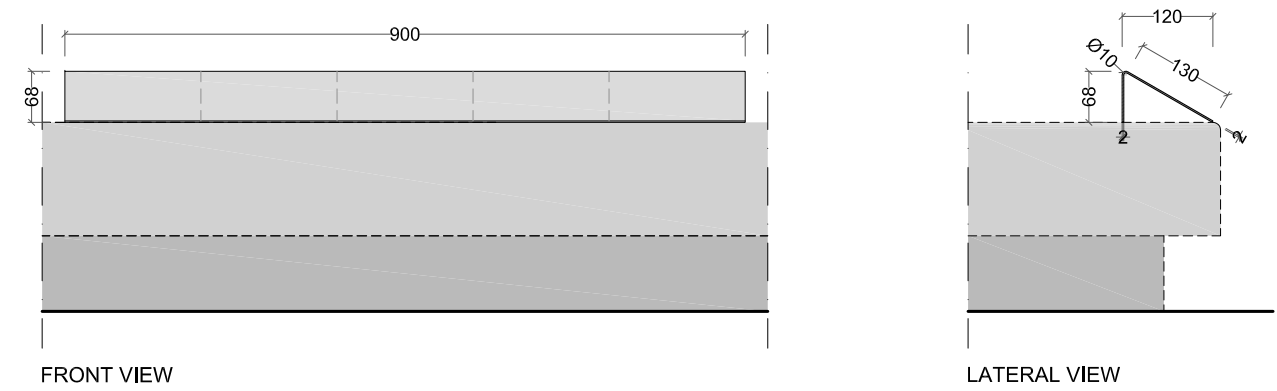

Section colour

1:10

LH_T3-H130L180

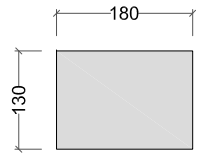

FRONT VIEW

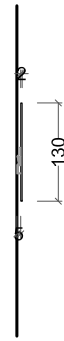

LATERAL VIEW

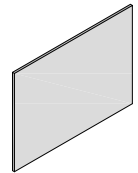

AXONOMETRIC VIEW

LH_T3-H130L360

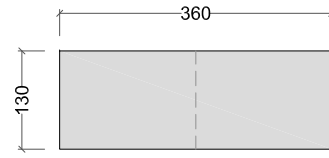

FRONT VIEW



LATERAL VIEW

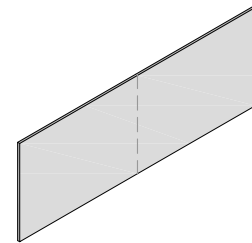

AXONOMETRIC VIEW

LH_T3-H260L180

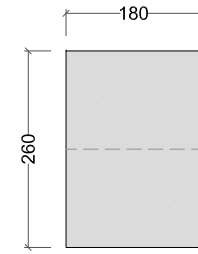

FRONT VIEW



LATERAL VIEW

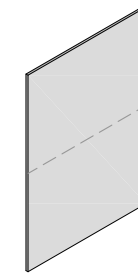

AXONOMETRIC VIEW

LH_T3-H130L540

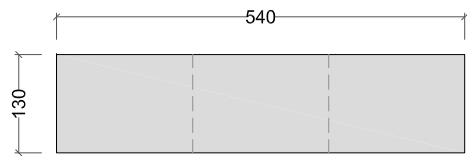

FRONT VIEW

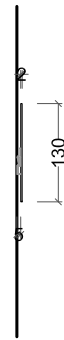

LATERAL VIEW

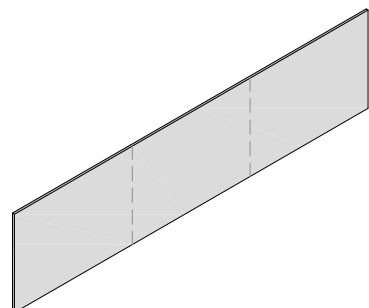

AXONOMETRIC VIEW

LH_T3-H260L360

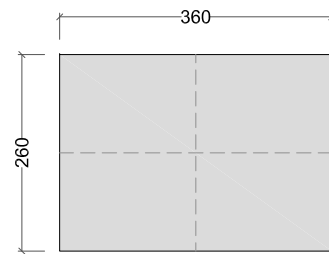

FRONT VIEW



LATERAL VIEW

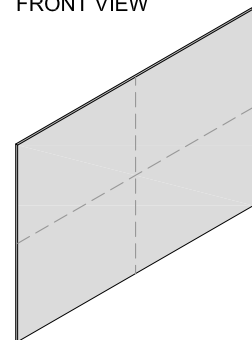

AXONOMETRIC VIEW

LH_T3-H390L180

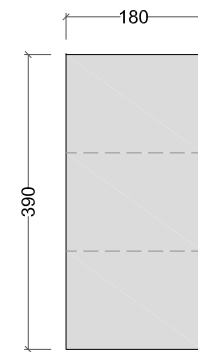

FRONT VIEW



LATERAL VIEW

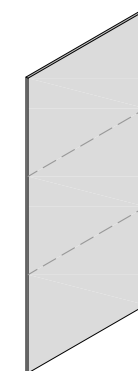

AXONOMETRIC VIEW

Section colour 

1:10

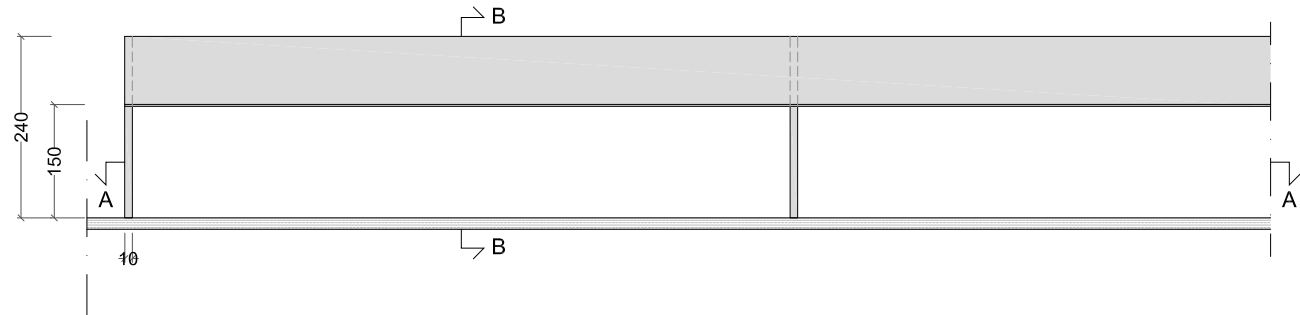

FRONT VIEW

1:10

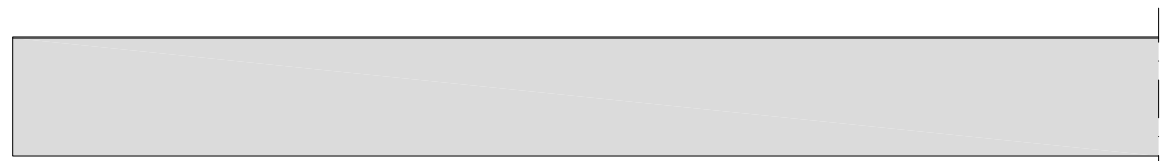

TOP VIEW

1:10

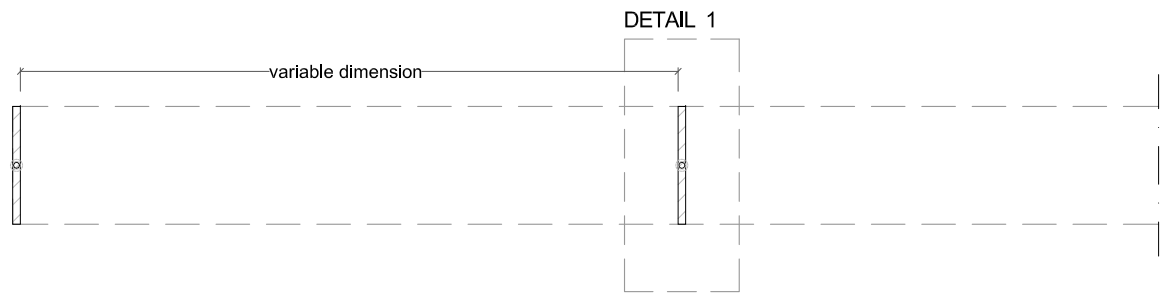

SECTION A

1:10

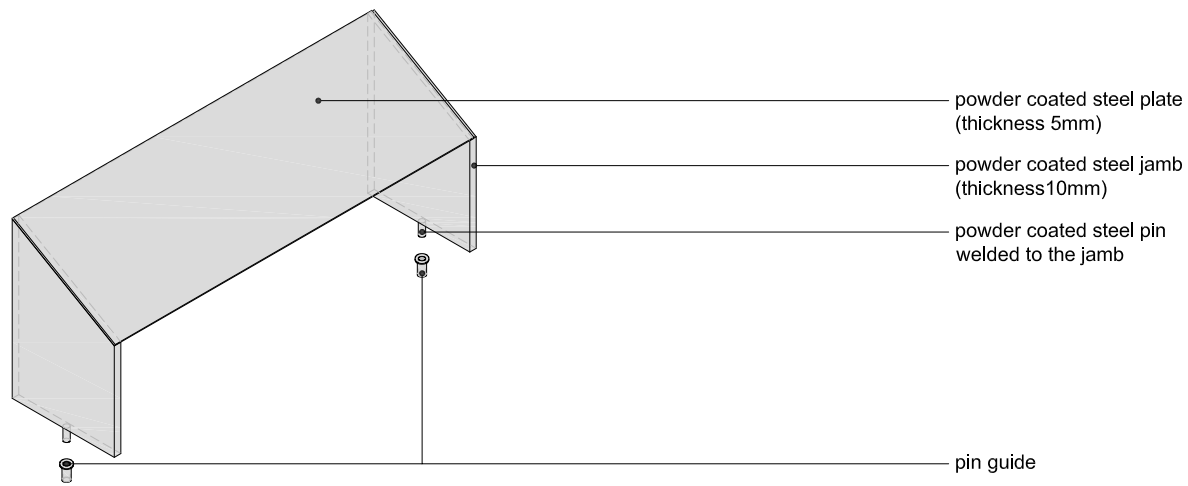

AXONOMETRIC VIEW

1:10

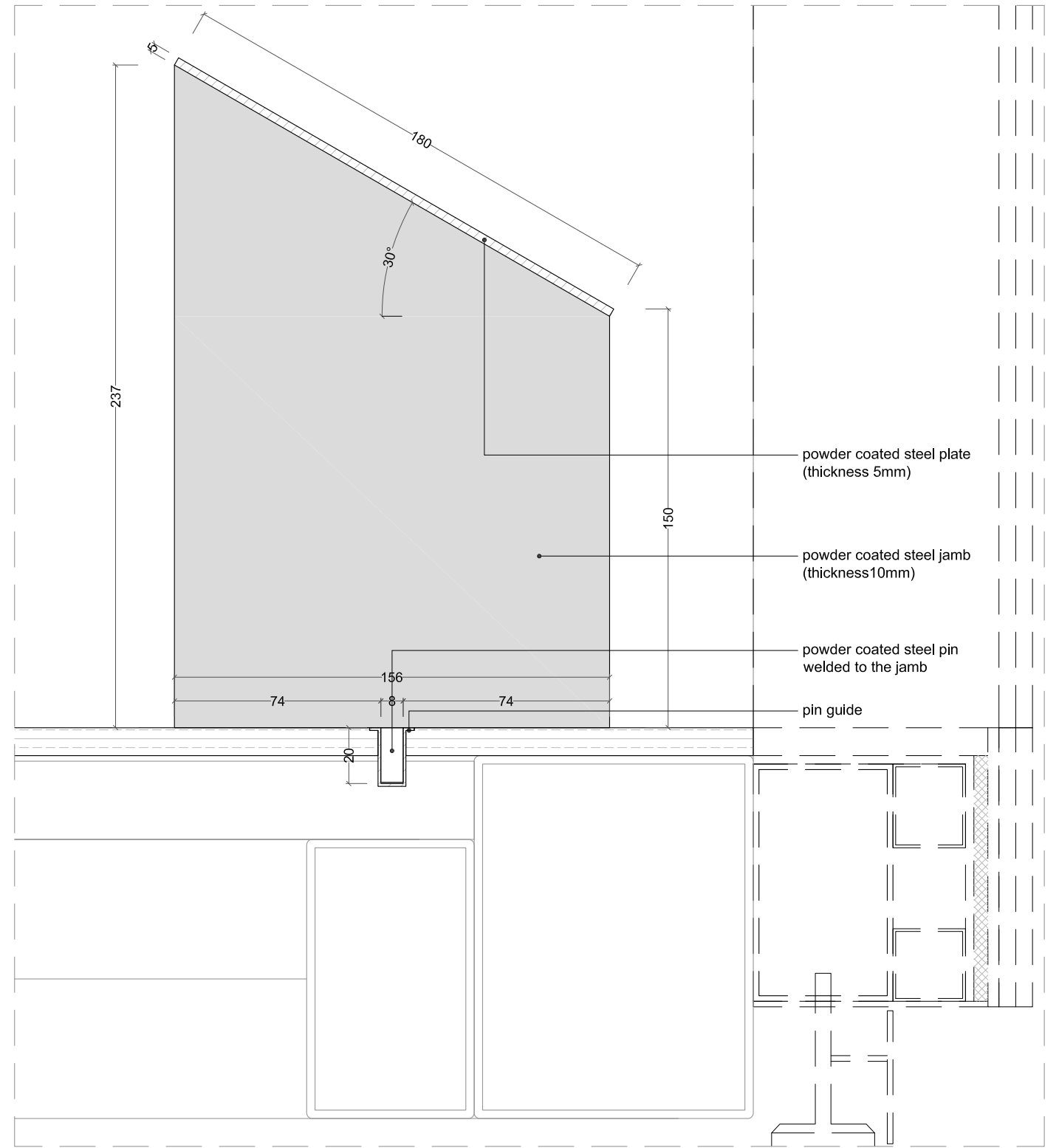

SECTION B

1:2

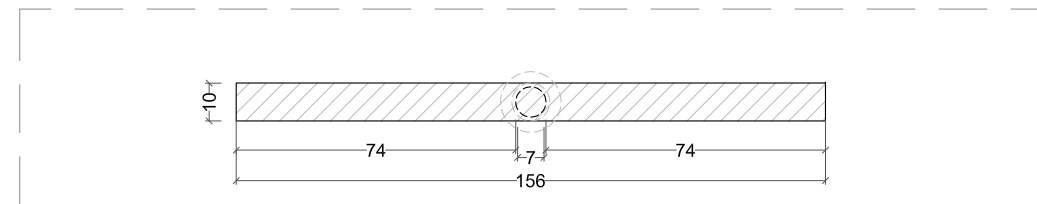

DETAIL 1

1:2

Section colour

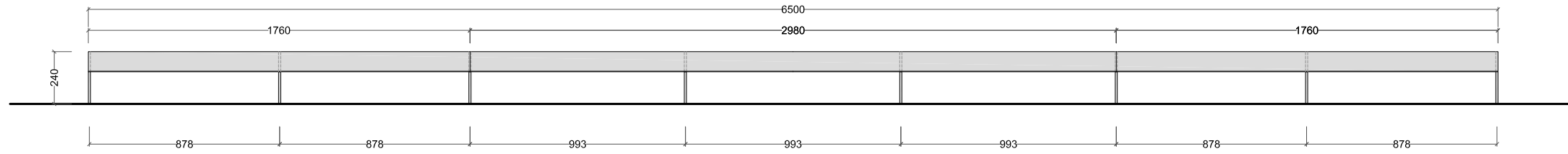

ROOM 11

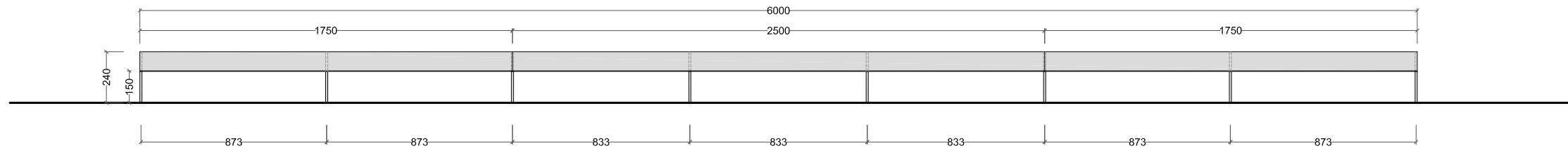

ROOM 13

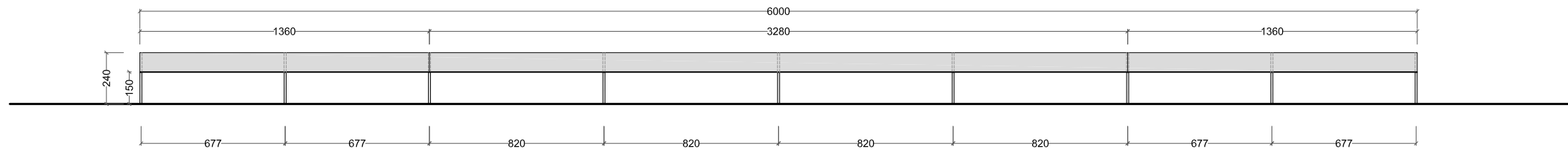

ROOM 16

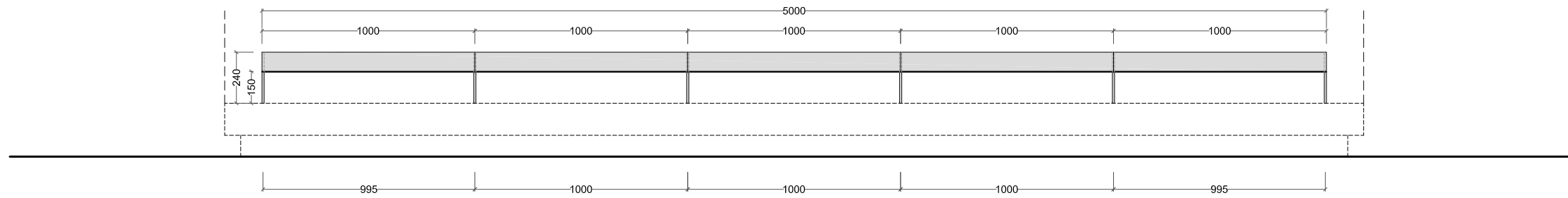

ROOM 19



ROOM 24

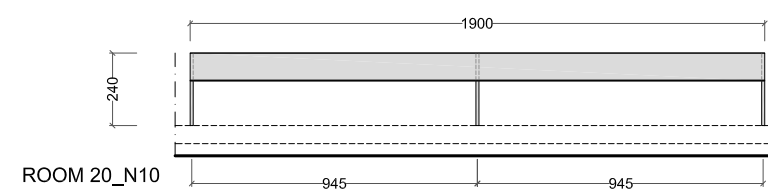
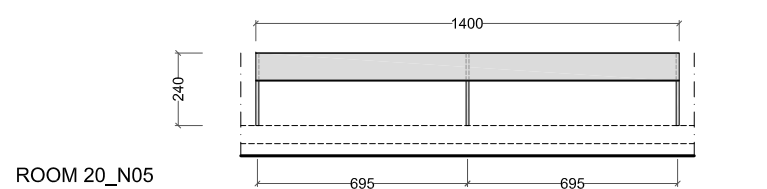
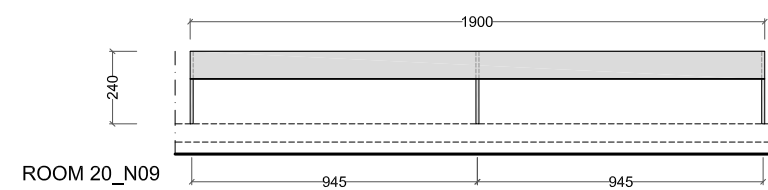
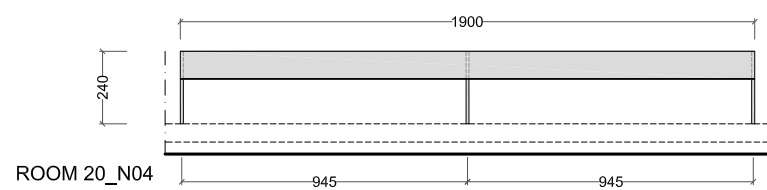
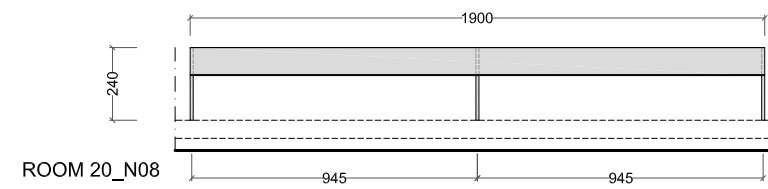
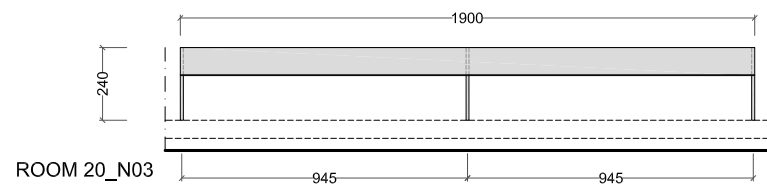
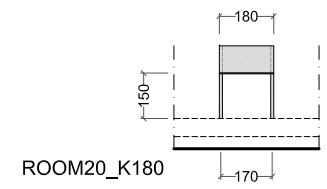
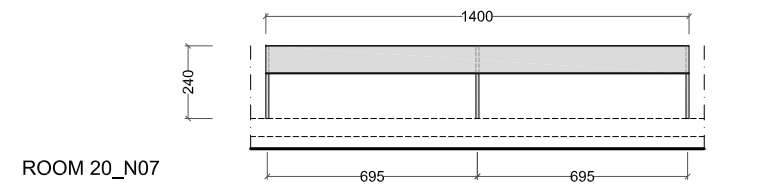
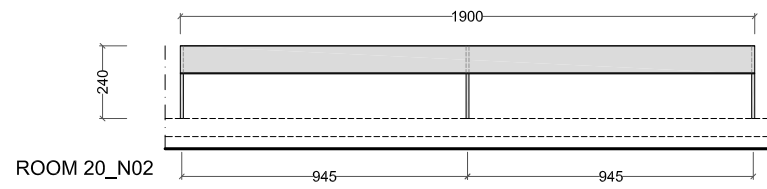
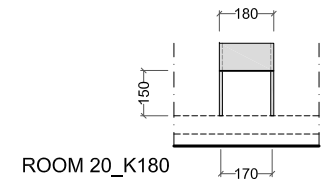
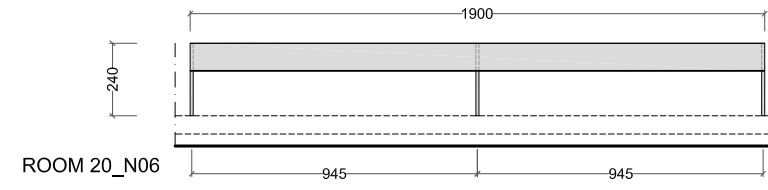
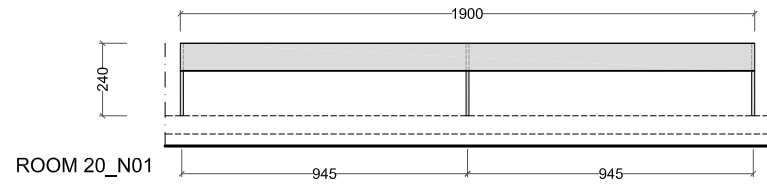

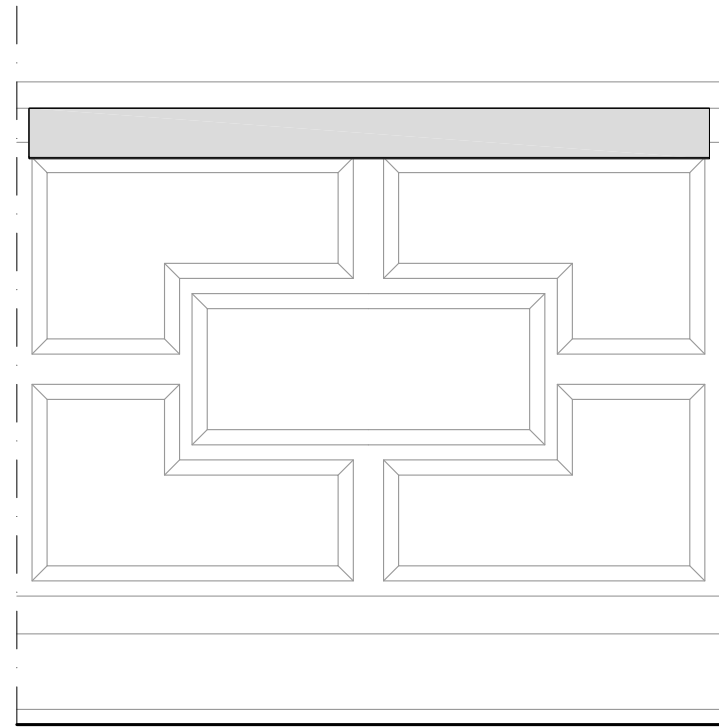

FRONT VIEW

1:10

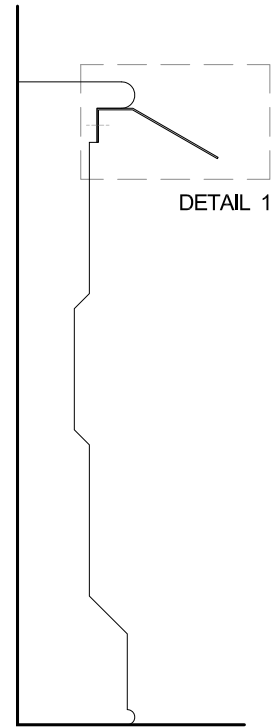

SECTION A

1:10

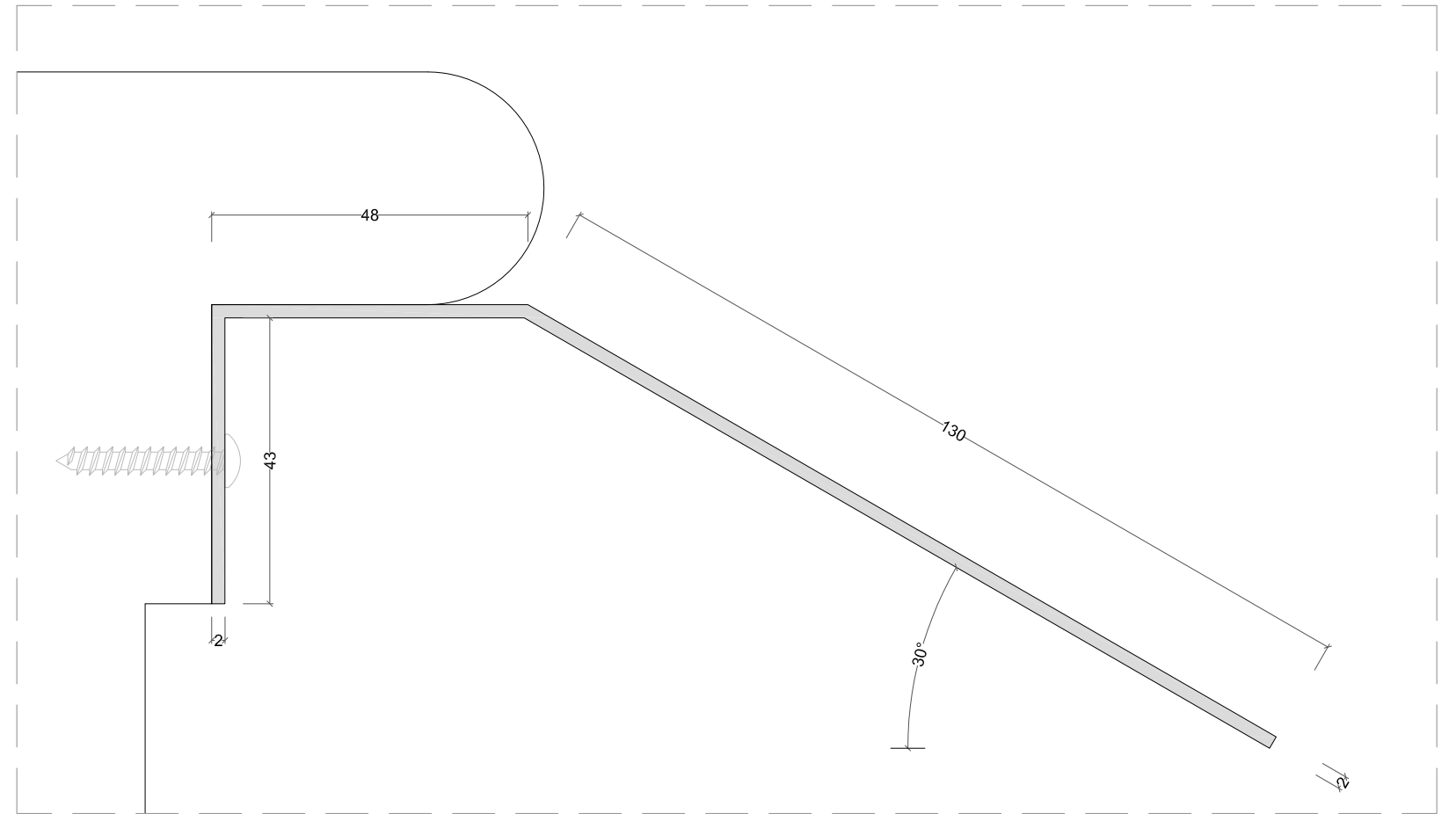

DETAIL 1

1:1

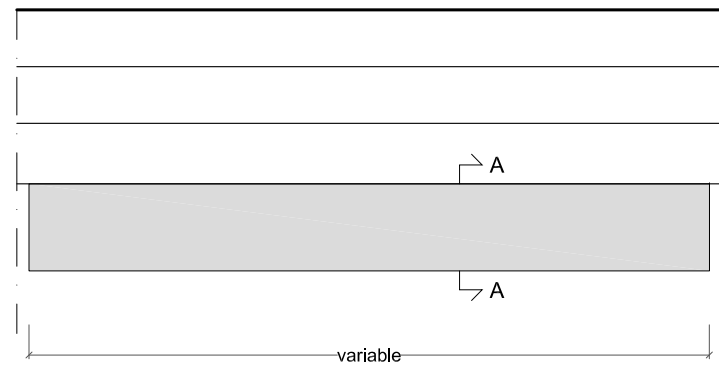

TOP VIEW

1:10

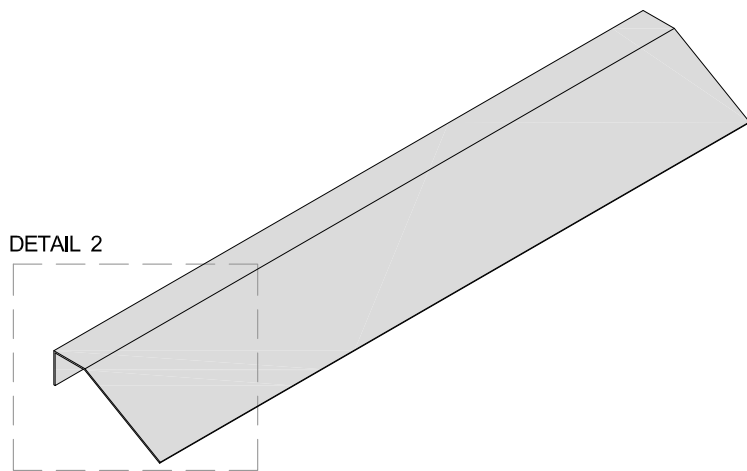

DETAIL 2

AXONOMETRIC VIEW

1:10

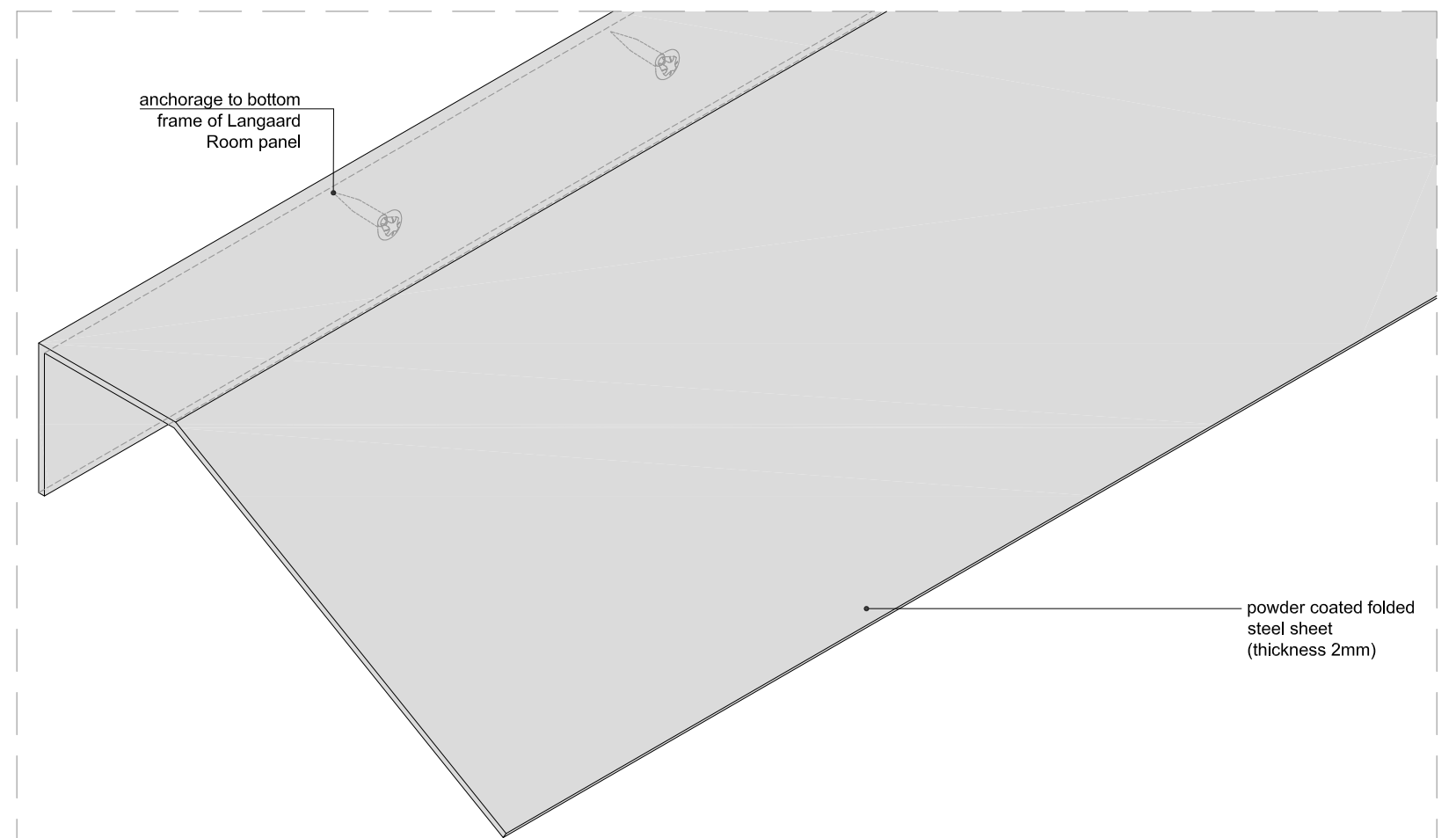

DETAIL 2

1:2

Section colour

powder coated folded
 steel sheet
 (thickness 2mm)

LH_T5-L180

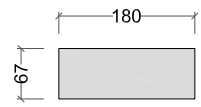

FRONT VIEW

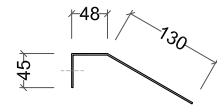

LATERAL VIEW

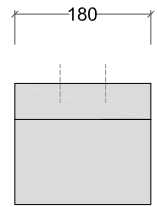

PLAN

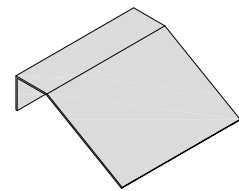

AXONOMETRIC VIEW

LH_T5-L360

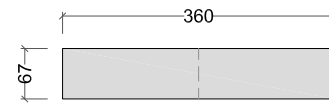

FRONT VIEW

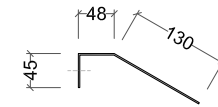

LATERAL VIEW

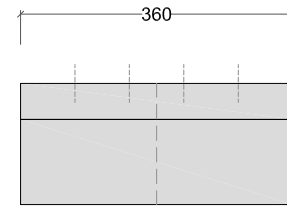

PLAN

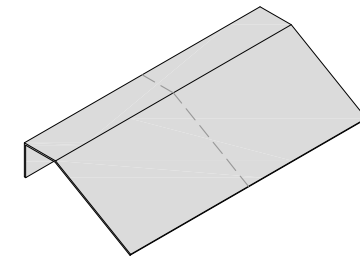

AXONOMETRIC VIEW

LH_T5-L900

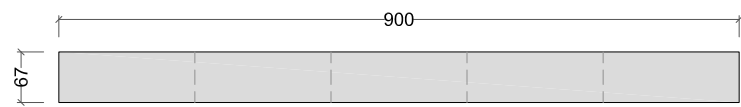

FRONT VIEW

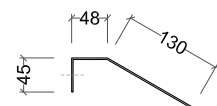

LATERAL VIEW

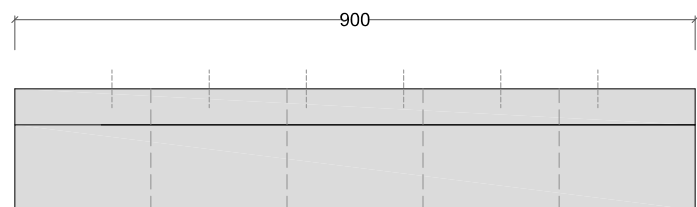

PLAN

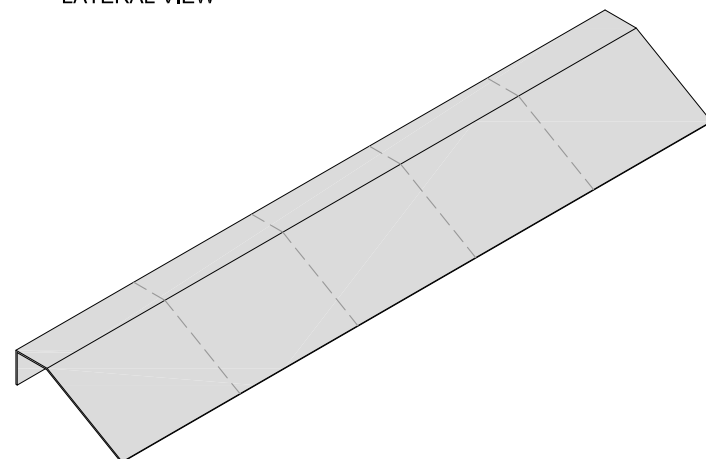

AXONOMETRIC VIEW

Section colour 

1:10