

**NB! ALLE MÅL MÅ
KONTROLLERES
PÅ STEDET!**

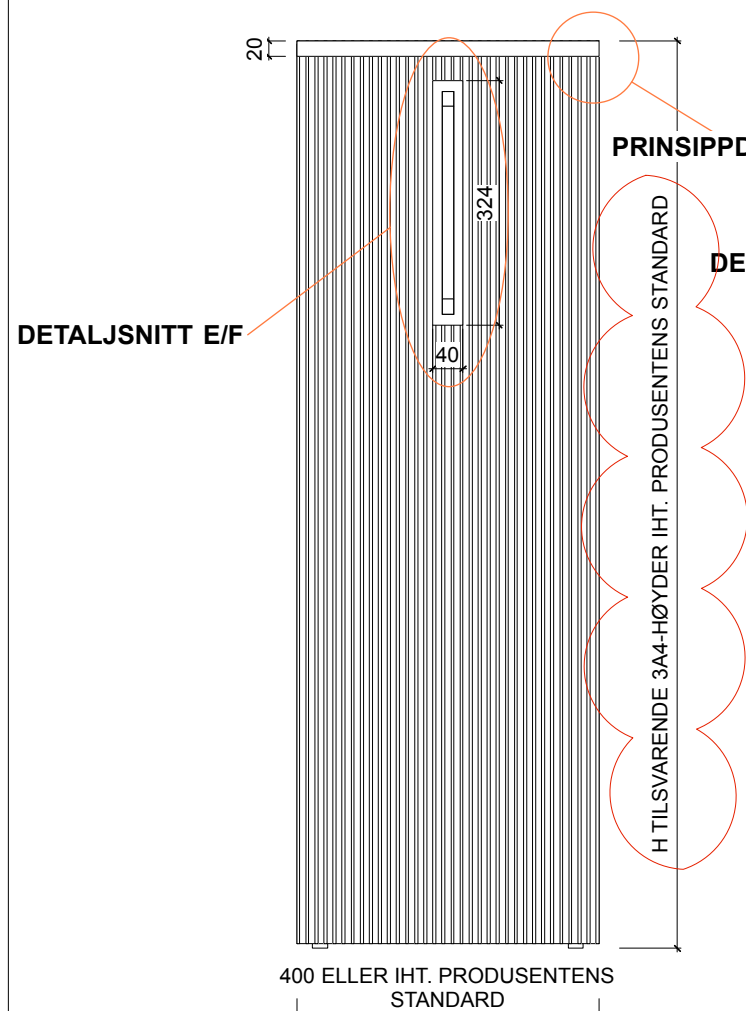

OPPRISS FRONT

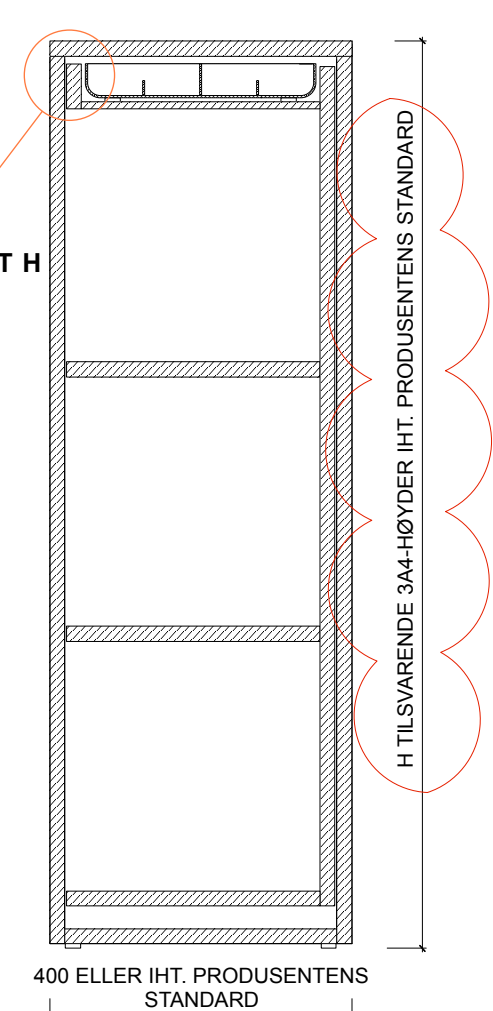

SNITT AA

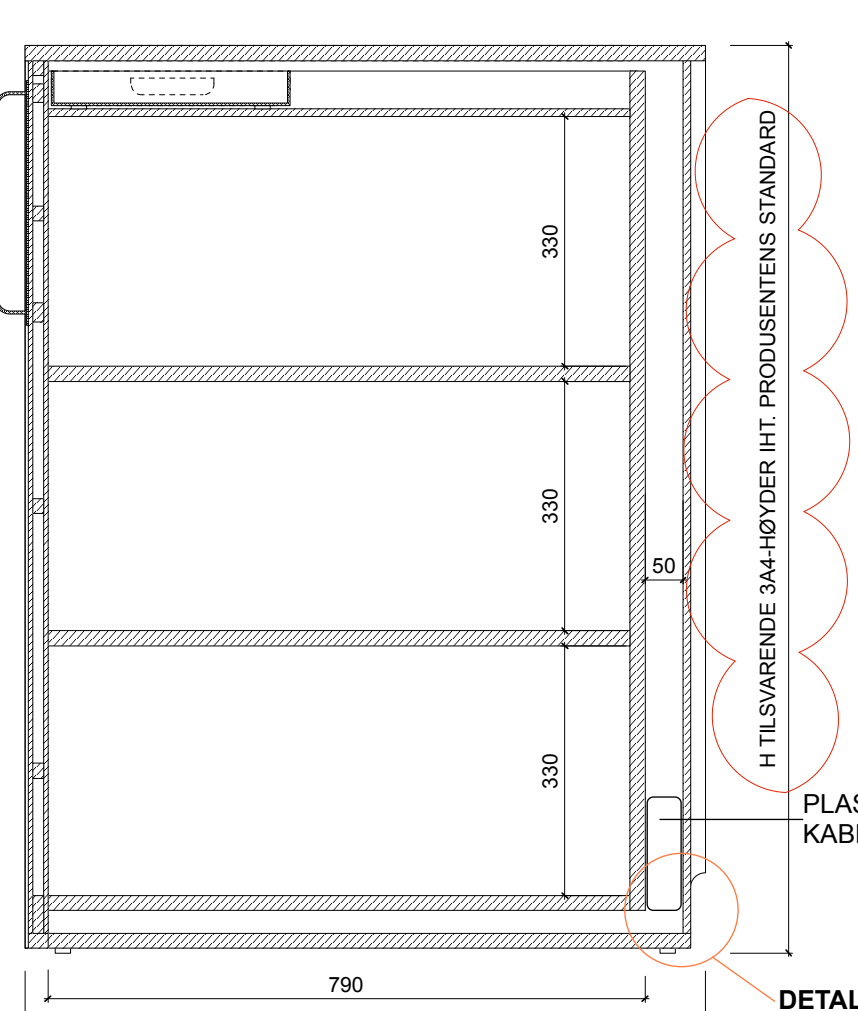

SNITT BB

DETALJSNITT D

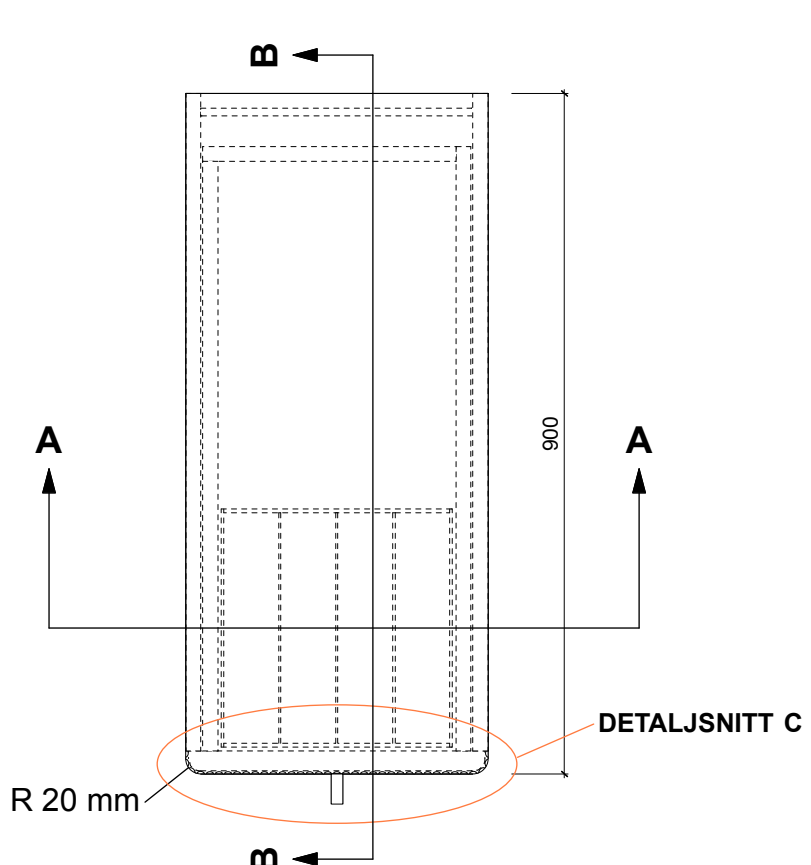

PLAN PRINSIPP UTTREKSKAP 3xA4

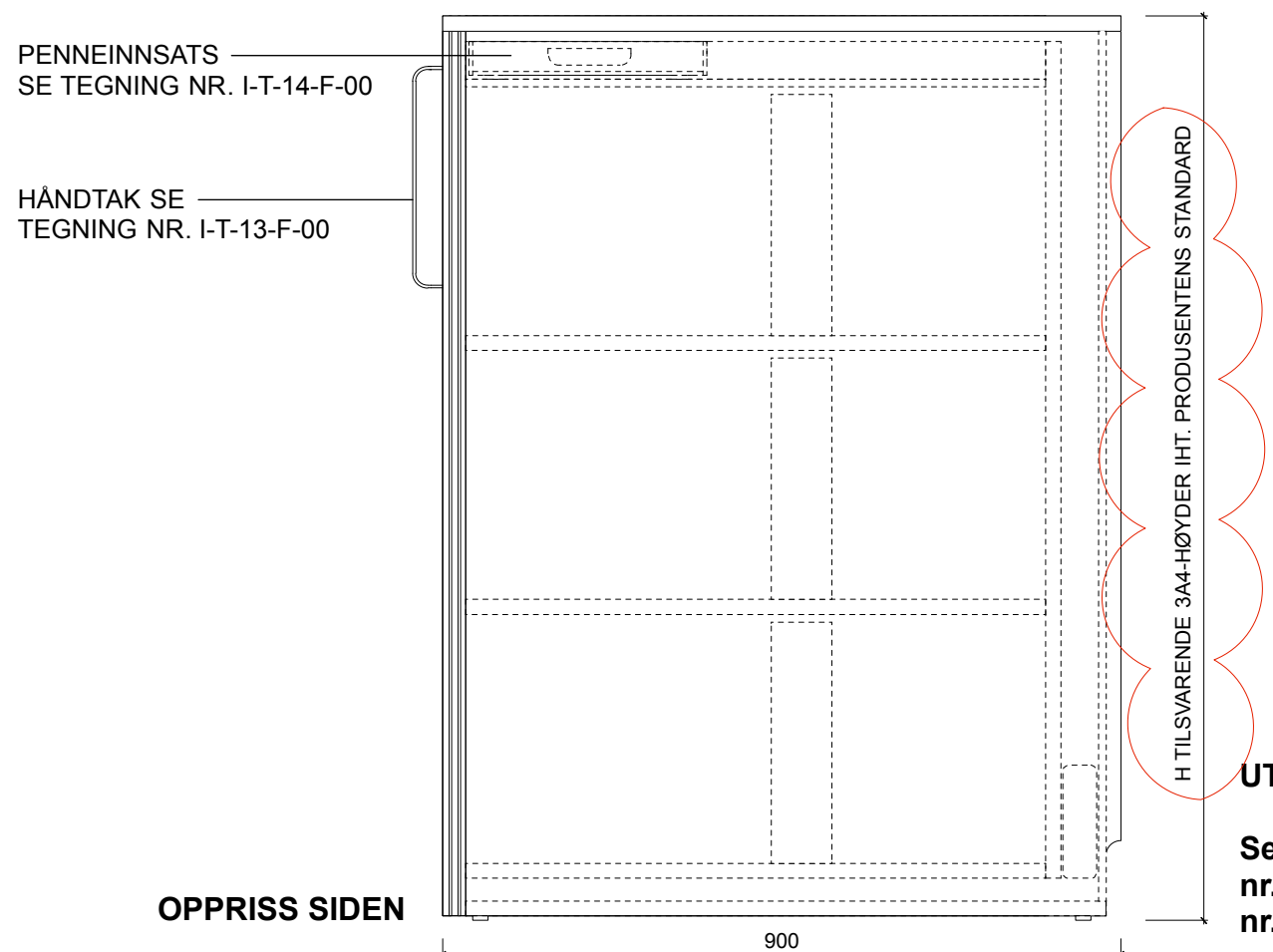

OPPRISS SIDEN

UTTREKSKAP 3xA4

Se detaljtegning
nr. I-T-14-F-00
nr. I-T-15-F-00

01	29.05.2017	Revidert tekst ang. høyde til skap	SC
Rev	Dato	Revidering	Sign
Prosj. nr.	Byggesak	Rammeavtale arbeidsplassmøbler	
1632			
Byggherre	STORTINGET		
Tegning	UTTREKSKAP 3A4		
Tegn.nr.			
Disiplin	Tegningstype	Løpenummer	Status
I	T	12	F
Revisjon	01		
Mål	1:10 @ A3		
Dato	Sign.	Sign. KS	
07.03.17	FMF	KG	



**NB! ALLE MÅL MÅ
KONTROLLERES
PÅ STEDET!**

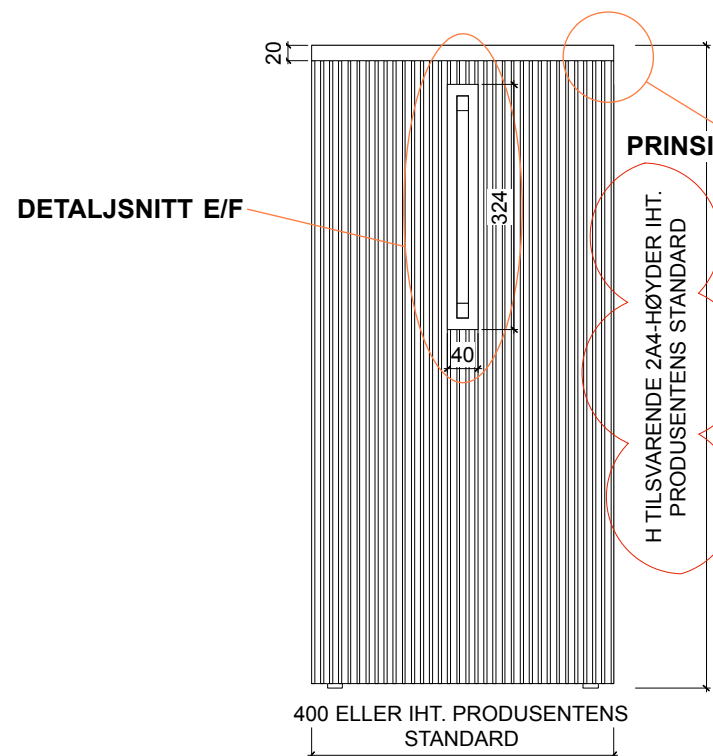

OPPRISS FRONT

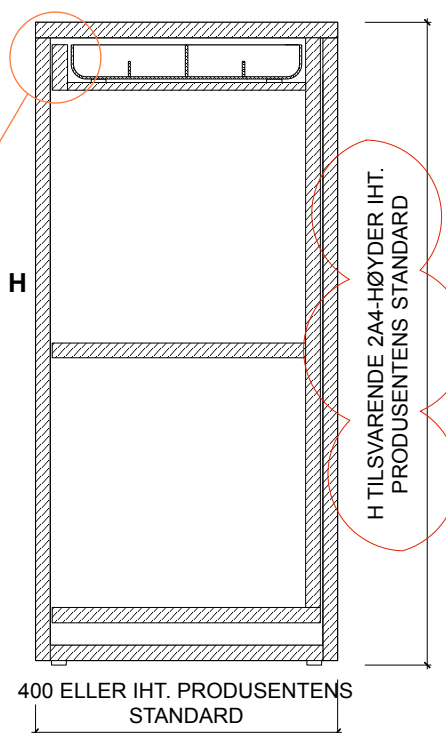

SNITT AA

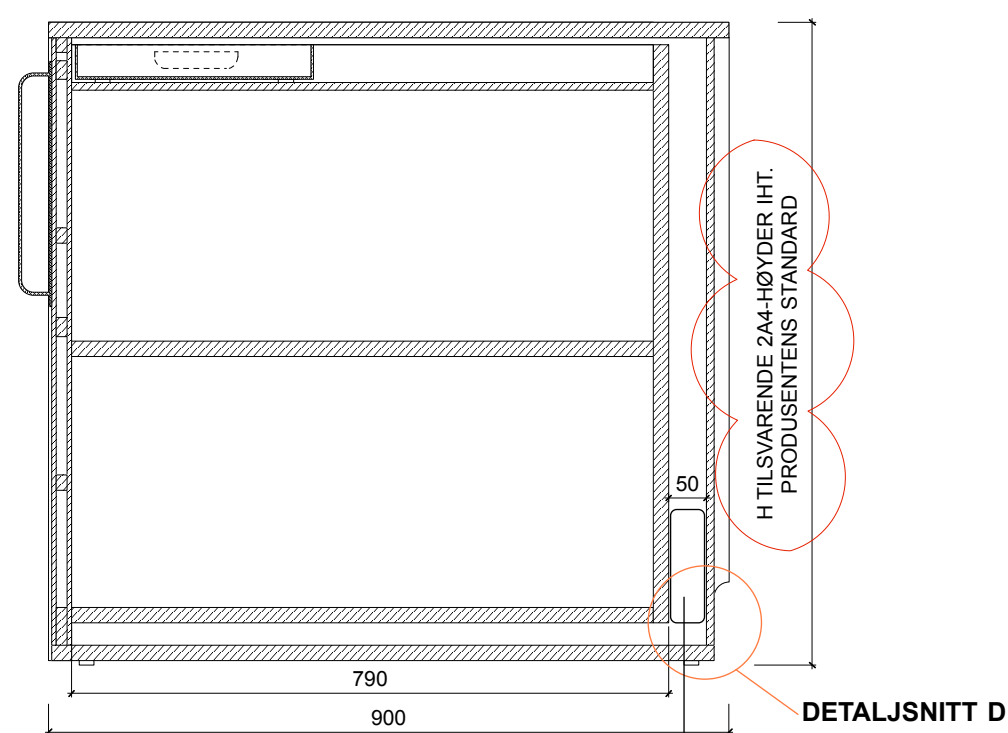

SNITT BB

PLASS + UTSPARING FOR
KABELGJENNOMFØRING

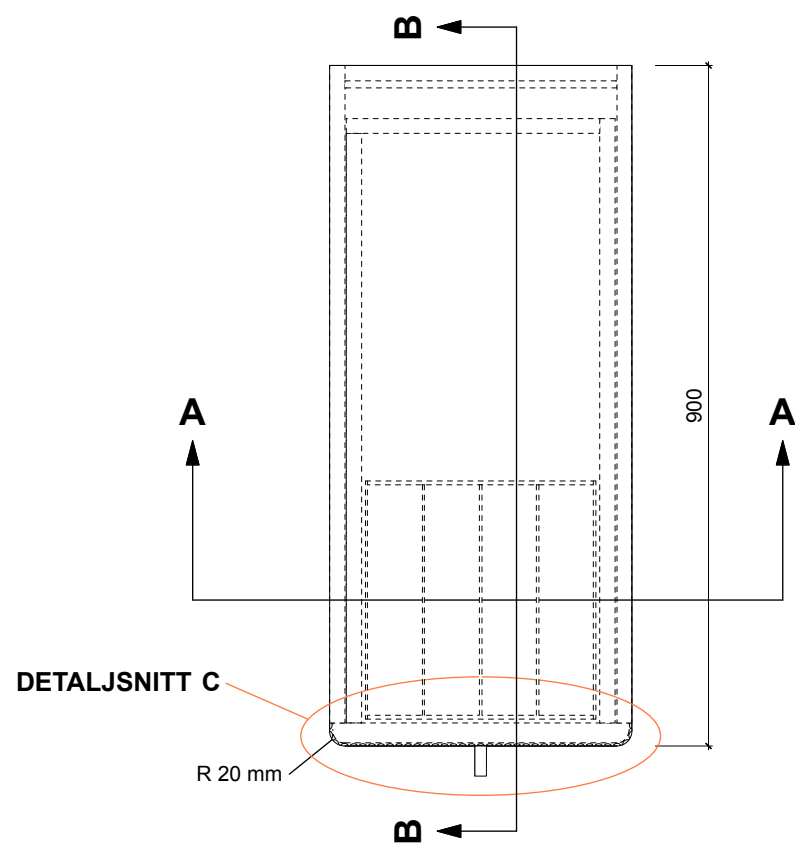

PLAN PRINSIPP UTTREKSKAP 2xA4

PENNEINNSATS
SE TEGNING NR. I-T-14-F-00

HÅNDTAK SE
TEGNING NR. I-T-13-F-00

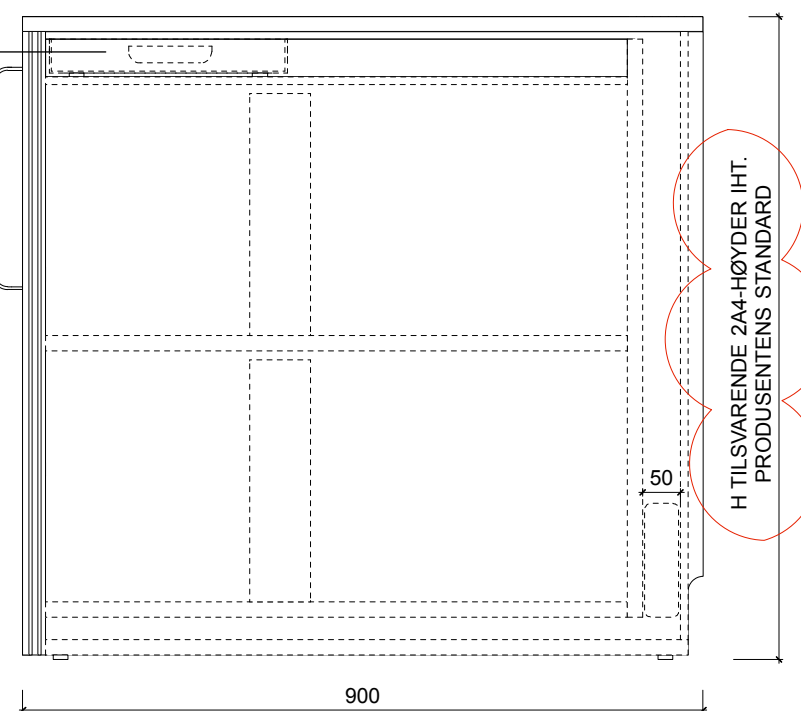

OPPRISS SIDEN

UTTREKSKAP 2xA4

Se detaljtegning nr. I-T-14-F-00
I-T-15-F-00

01	29.05.2017	Revidert tekst ang. høyde til skap	SC
Rev	Dato	Revidering	Sign
Prosj. nr.	1632	Byggesak	Rammeavtale arbeidsplassmøbler
Byggherre	STORTINGET		
Tegning	UTTREKSKAP 2A4		
Tegn.nr.			
Disiplin	Tegningstype	Løpenummer	Status
I	T	13	F
Mål	1:10 @ A3		
Dato	07.03.17	Sign.	Sign. KS
		FMF	KG



**NB! ALLE MÅL MÅ
KONTROLLERES
PÅ STEDET!**

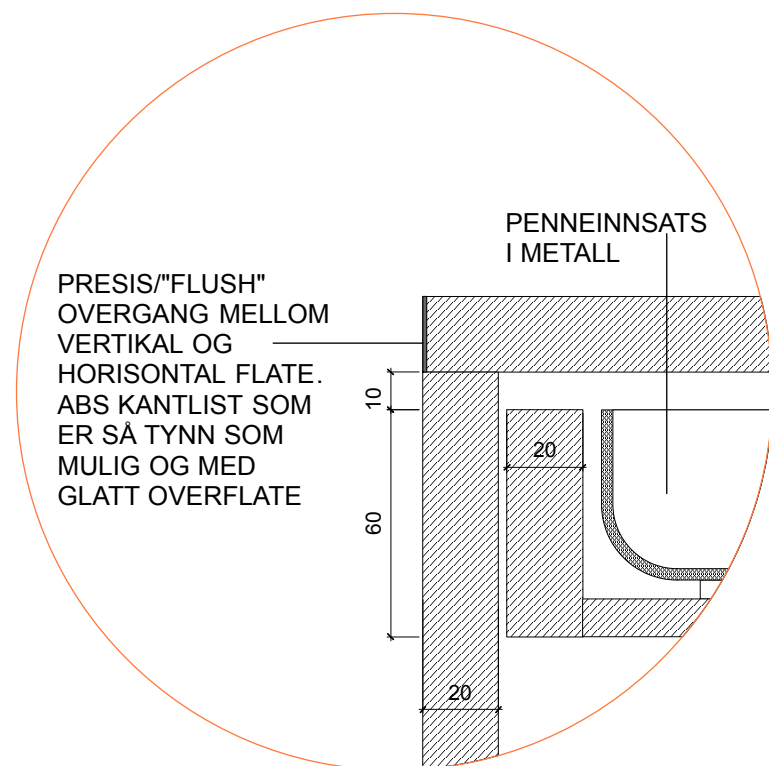

DETALJSNITT H - ALTERNATIV 1 (1:2)

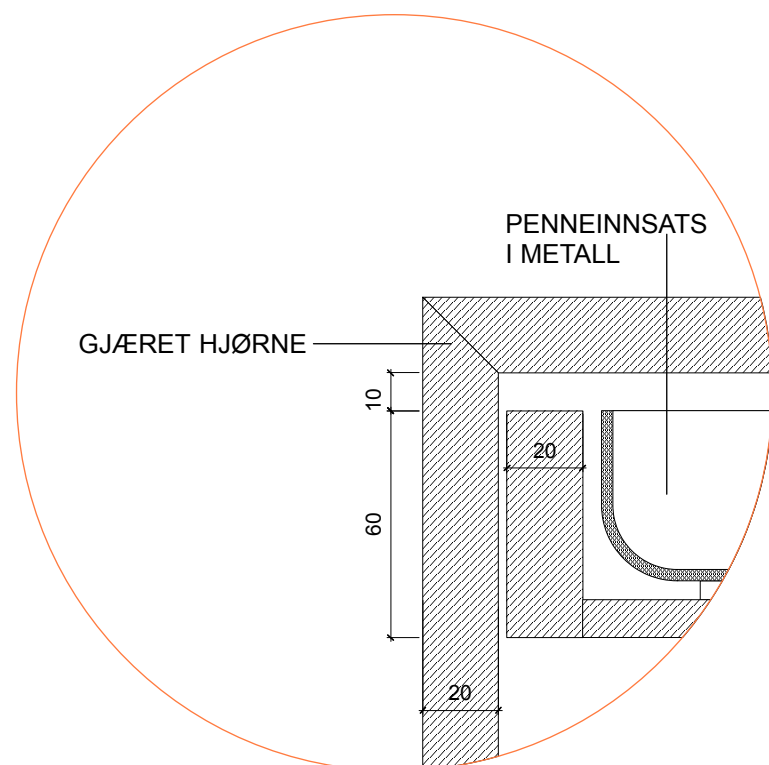

DETALJSNITT H - ALTERNATIV 2 (1:2)

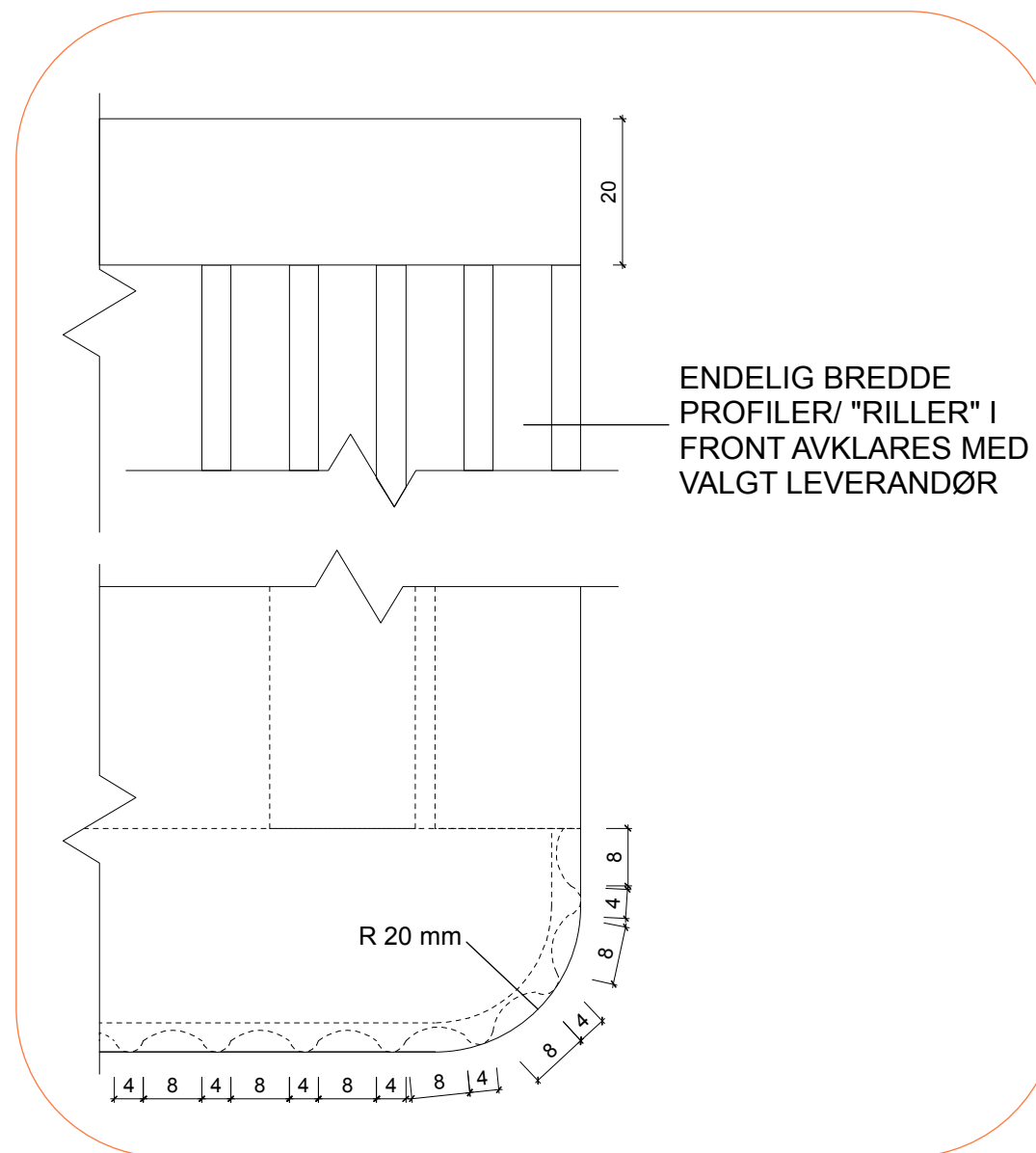

PRINSIPDETALJ F (1:1)

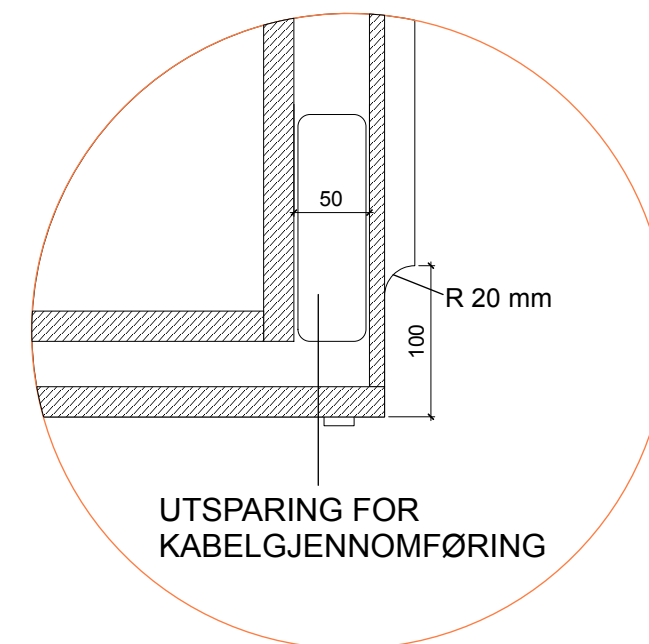

DETALJSNITT D (1:5)

PRINSIPDETALJER

01	05.04.2017	Rev. detaljsnitt H - to alternativer	SC
Rev	Dato	Revidering	Sign
Prosj. nr.	1632	Byggesak	Rammeavtale arbeidsplassmøbler
Byggherre	STORTINGET		
Tegning	PRINSIPDETALJER		
Tegn.nr.			
Disiplin	Tegningstype	Løpenummer	Status
I	T	14	F
Mål	1:5/1:2/1:1 @ A3		
Dato	07.03.17	Sign.	Sign. KS
		FMF	KG



Copyright • CADI AS

CADI AS • TLF 23274040 • E-POST eb@cadi.no

**NB! ALLE MÅL MÅ
KONTROLLERES
PÅ STEDET!**

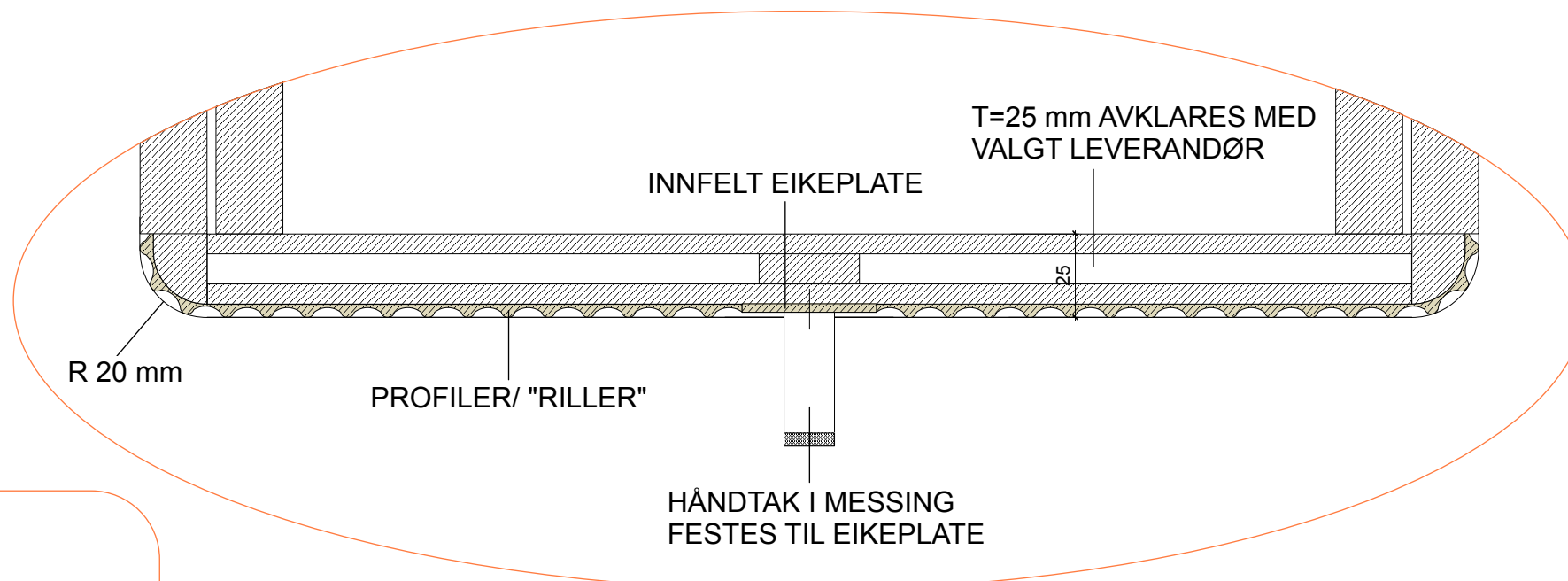

DETALJSNITT C (1:2)

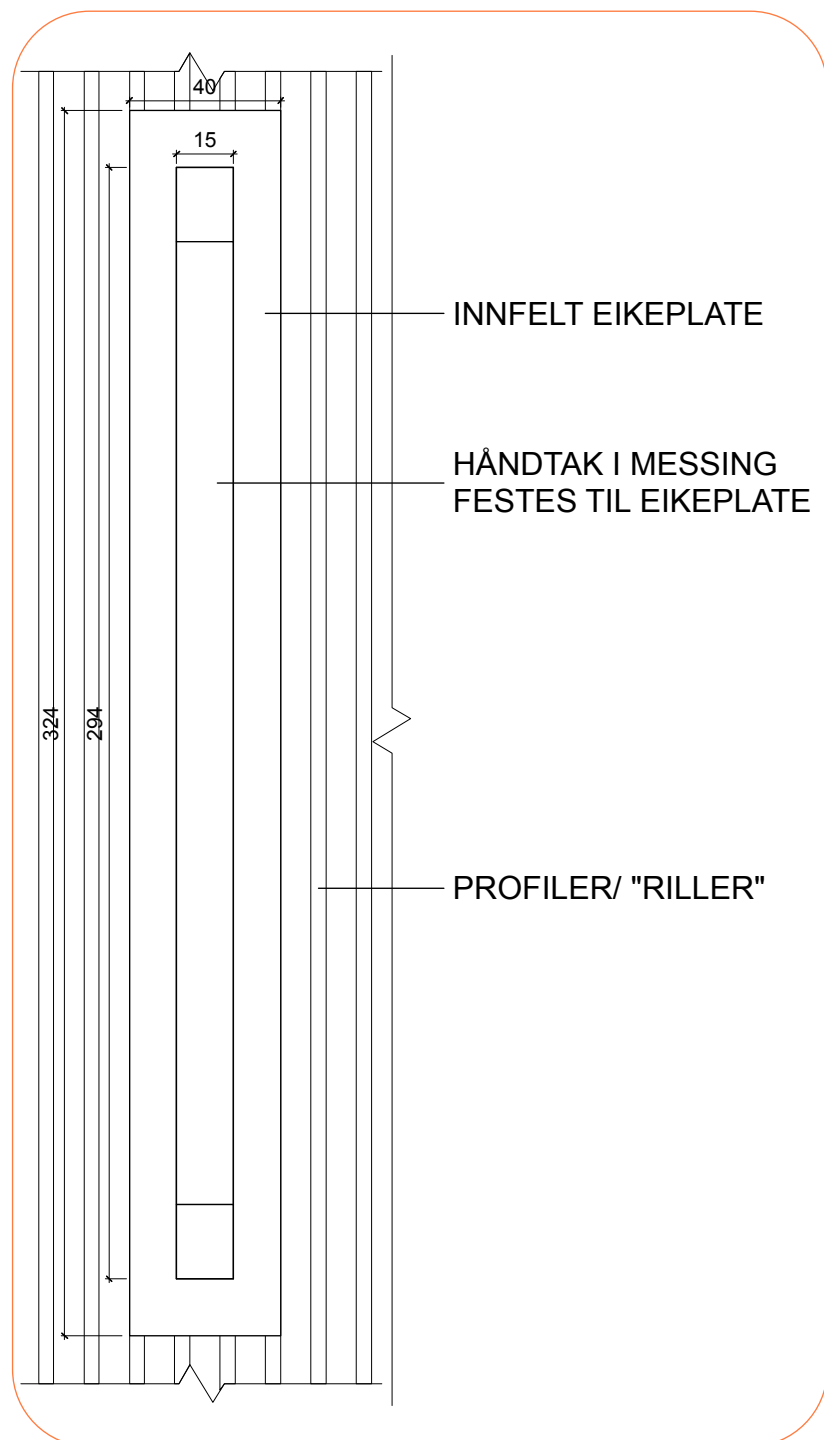

DETALJSNITT F (1:2)

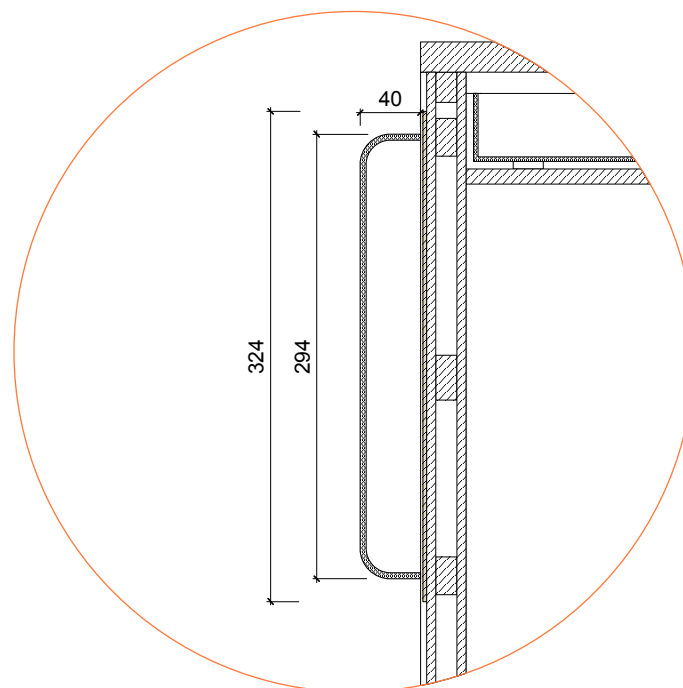

DETALJSNITT E (1:5)

**NB! HÅNDTAK I TO STØRRELSER:
L 294 mm og L 198 mm**

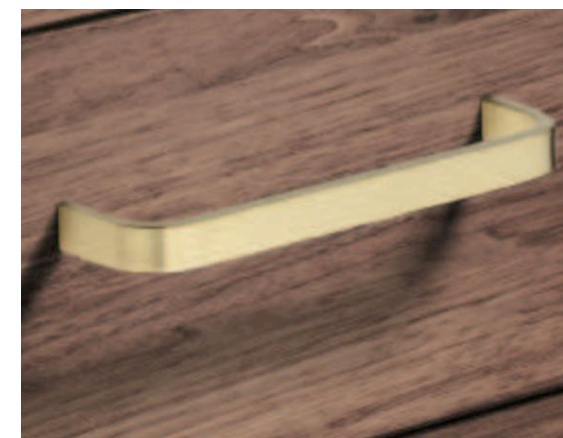

HÅNDTAK

Rev	Dato	Revidering	Sign	
Proj. nr.	1632	Byggesak	Rammeavtale arbeidsplassmøbler	
Byggherre	STORTINGET			
Tegning	HÅNDTAK			
Tegn.nr.				
Disiplin	Tegningstype	Løpenummer	Status	Revisjon
I	T	15	F	00
Mål	1:5/1:2 @ A3			
Dato	07.03.17	Sign.	FMF	Sign. KS KG

CADi
contemporary architecture design interior

Copyright • CADi AS

CADi AS • TLF 23274040 • E-POST eb@cadi.no

**NB! ALLE MÅL MÅ
KONTROLLERES
PÅ STEDET!**

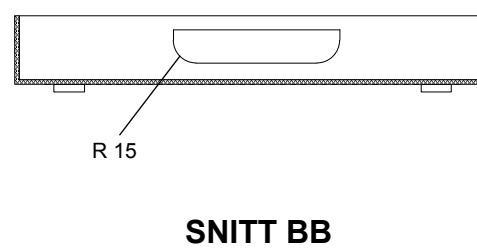
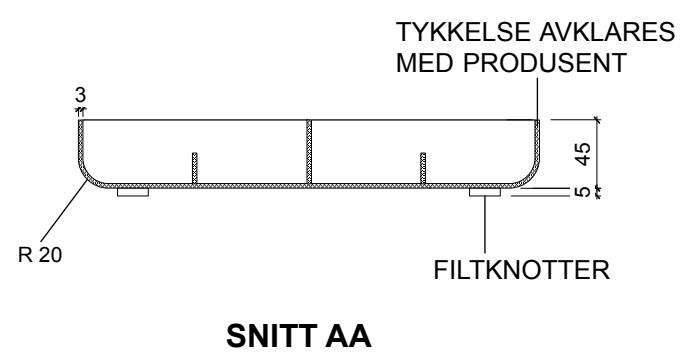
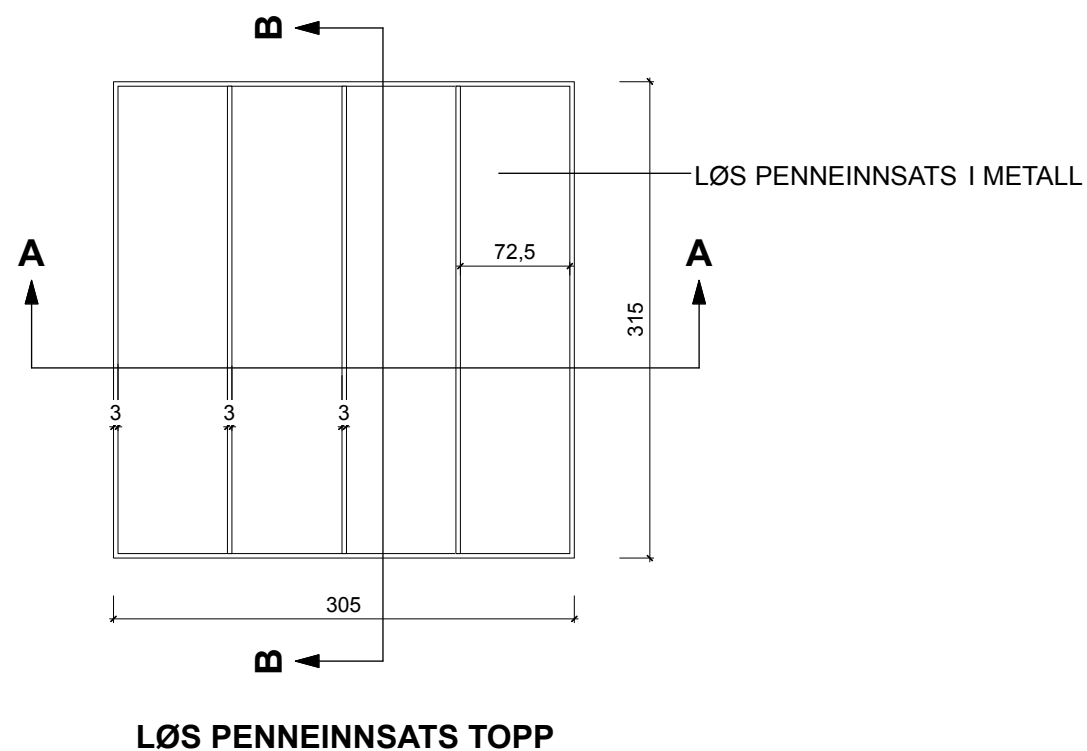

PENNEINNSATS

Rev	Dato	Revidering	Sign
Prosj. nr.	1632	Byggesak	Rammeavtale arbeidsplassmøbler
Byggherre	STORTINGET		
Tegning	PENNEINNSATS		
Tegn.nr.			
Disiplin	Tegningstype	Løpnummer	Status
I	T	16	F
Revisjon	00		
Mål	1:10 @ A3		
Dato	07.03.17	Sign.	FMF
		Sign.	KS
			KG

CADi
contemporary architecture design interior

**NB! ALLE MÅL MÅ
KONTROLLERES
PÅ STEDET!**

SKAP 5xA4 høyde

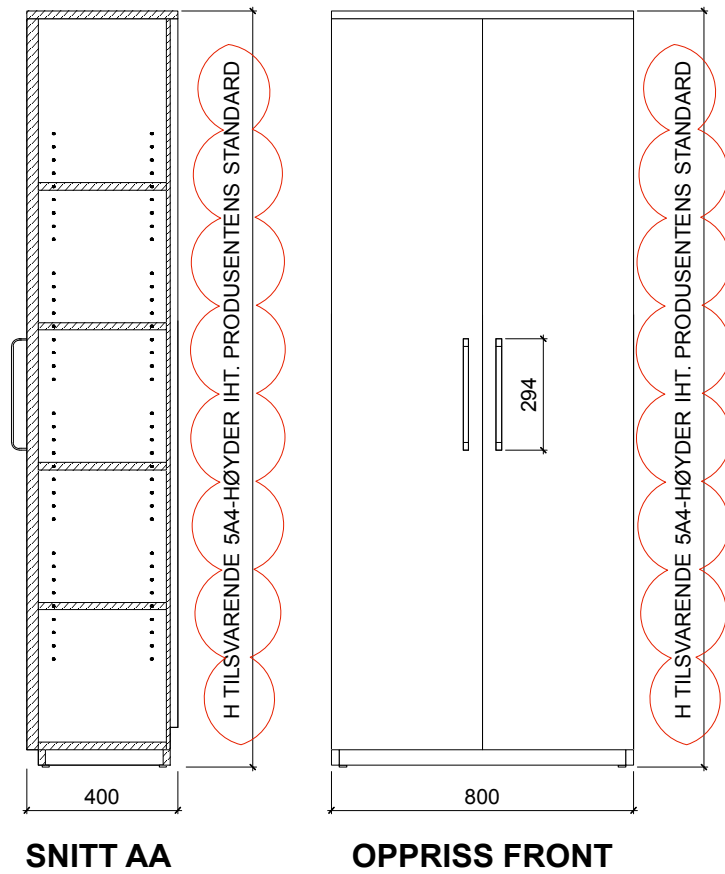

SKAP 2xA4 høyde

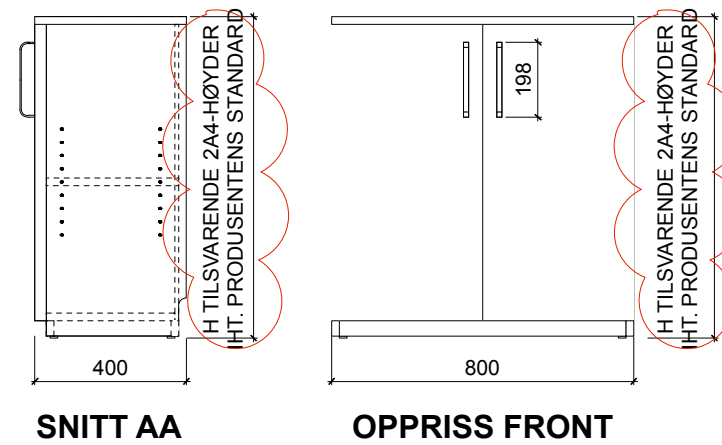

SKAP 3xA4 høyde

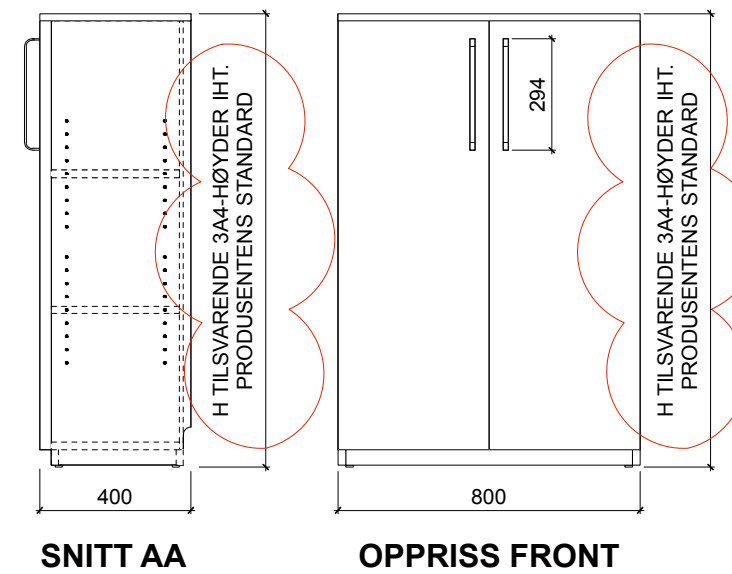

**NB! HÅNDTAK I TO
STØRRELSER:
L 294 mm og L 198 mm**

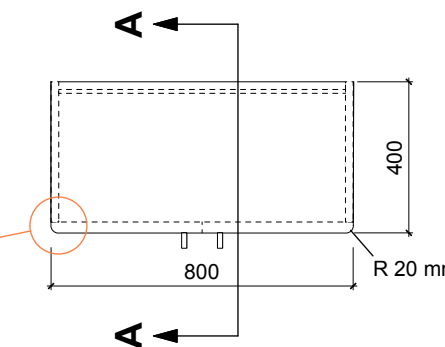
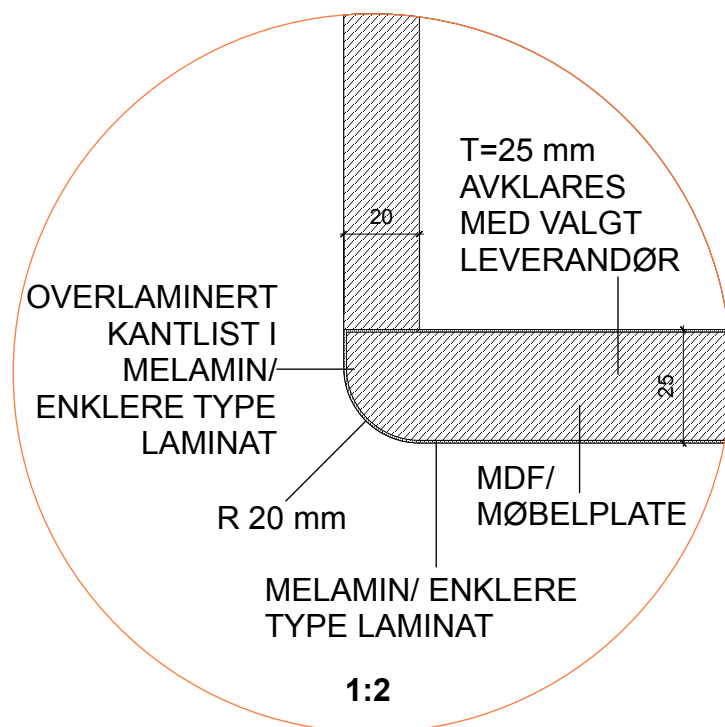

SKAP MED SLAGDØRER TYPE 1

03	29.05.2017	Revidert tekst ang. høyde til skap	SC
02	09.05.17	Endret type materiale, fra høytrykkslaminat til melamin/enklere type laminat	SC
01	05.05.17	Fjernet heitre kantlist	SC
Rev	Dato	Revidering	Sign

Prosj. nr. **1632** Byggesak **Rammeavtale arbeidsplassmøbler**

Byggherre **STORTINGET**

Tegning **SKAP MED SLAGDØRER TYPE 1**

Tegn.nr.

Disiplin	Tegningstype	Løpenummer	Status	Revisjon
I	T	17	F	03

Mål **1:20/1:2 @ A3**

Dato	Sign.	Sign.
07.03.17	FMF	KS



Copyright • CADI AS

CADI AS • TLF 23274040 • E-POST eb@cadi.no

NB! ALLE MÅL MÅ KONTROLLERES PÅ STEDET!

SKAP 5x4 høyde

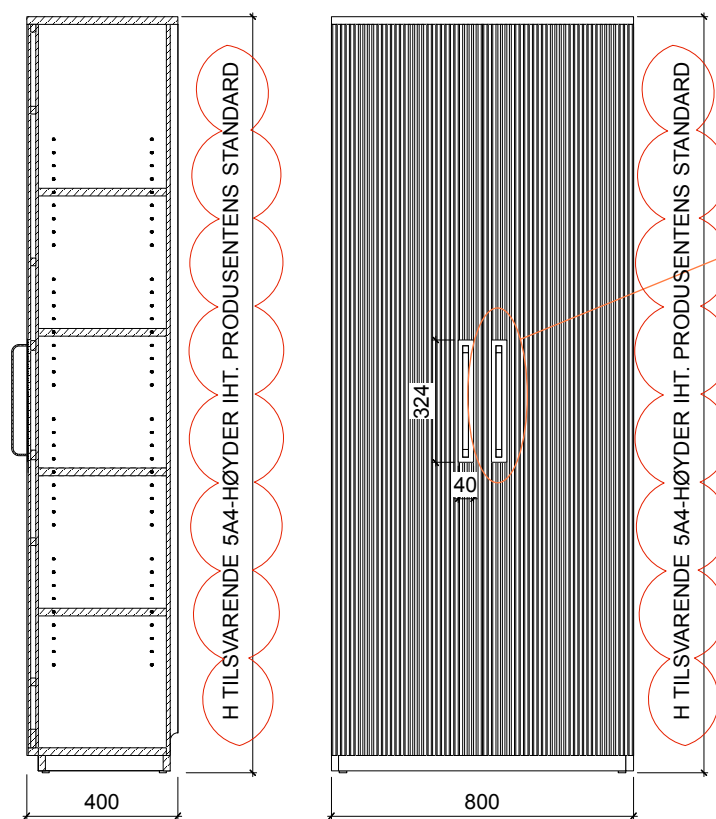

SNITT AA

OPPRISS FRONT

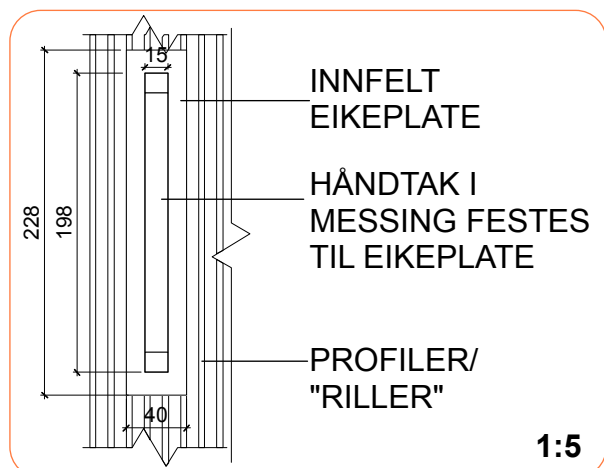

1:5

DETALJSNITT E/F

SKAP 2x4 høyde

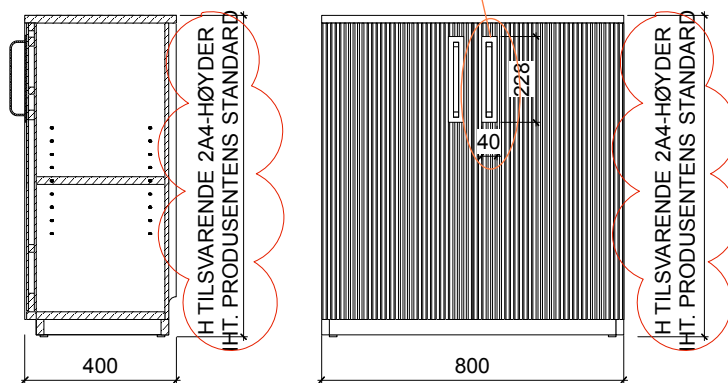

SNITT AA

OPPRISS FRONT

SKAP 3x4 høyde

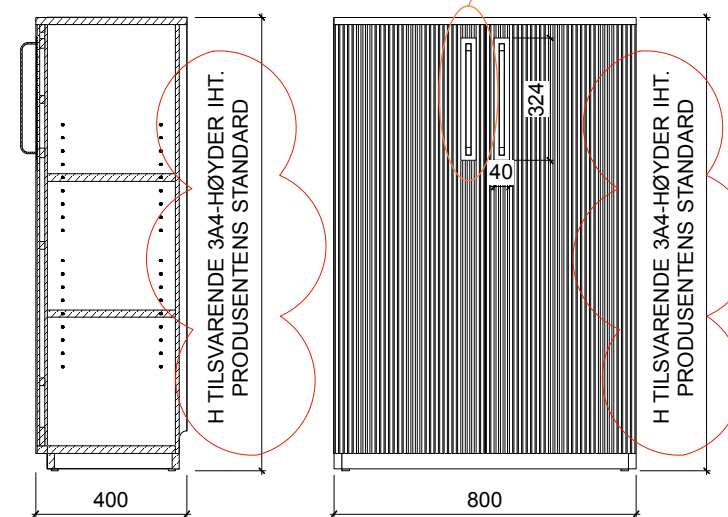

SNITT AA

OPPRISS FRONT

DETALJSNITT E/F

**NB! HÅNDTAK I TO STØRRELSER:
L 294 mm og L 198 mm**

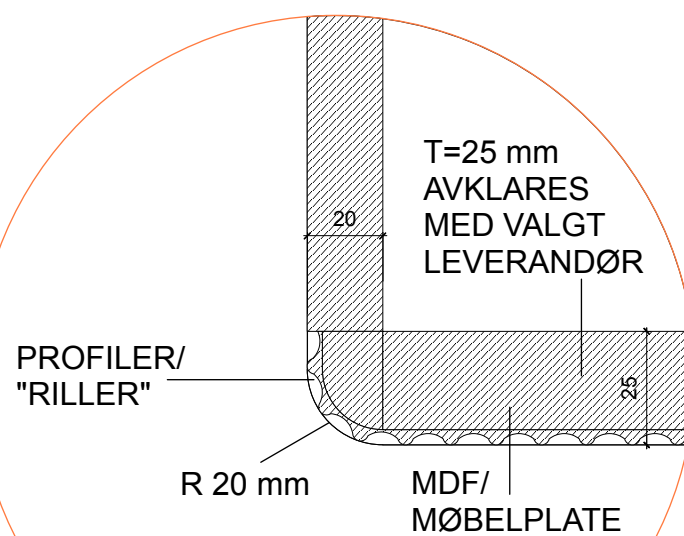

1:2

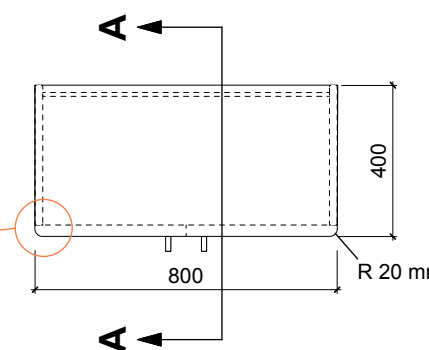

SKAP MED SLAGDØRER TYPE 2

01	29.05.2017	Revidert tekst ang. høyde til skap	SC
Rev	Dato	Revidering	Sign
Proj. nr.	1632	Byggesak	Rammeavtale arbeidsplassmøbler
Byggherre	STORTINGET		
Tegning	SKAP MED SLAGDØRER TYPE 2		
Tegn.nr.			
Disiplin	Tegningstype	Løpenummer	Status
I	T	18	F
Revisjon	01		
Mål	1:20/1:5/1:2 @ A3		
Dato	07.03.17	Sign.	Sign. KS
	FMF		KG



**NB! ALLE MÅL MÅ
KONTROLLERES
PÅ STEDET!**

UTTREKKBAR
GARDEROBESTANG

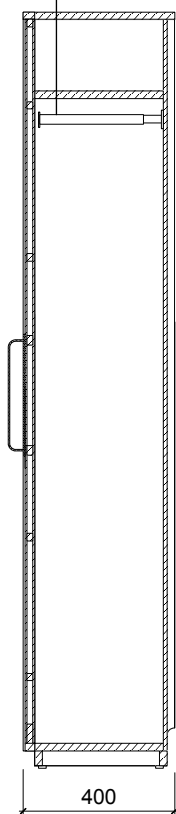

SNITT AA

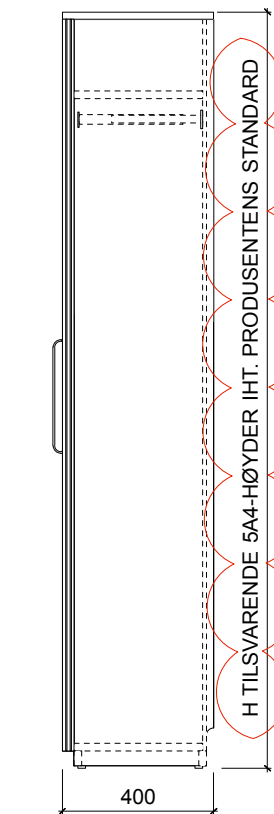

OPPRISS SIDEN

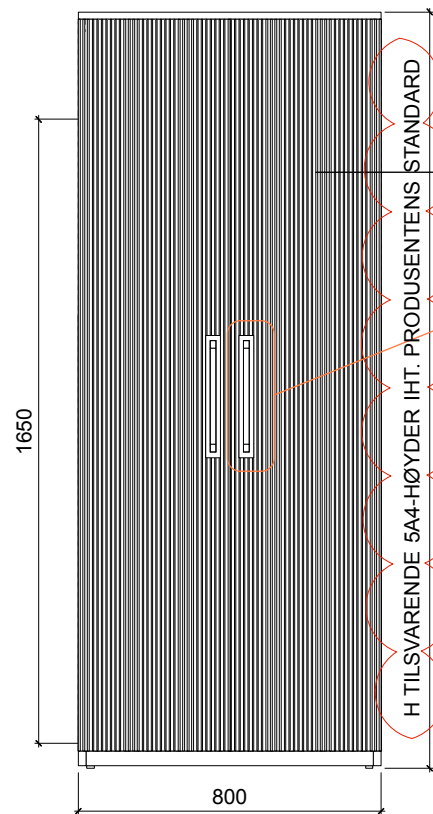

OPPRISS FRONT

DØRER MED KRAFTIG BESLAG
SKAL HA SPEIL PÅ INNSIDE

DETALJSNITT E/F

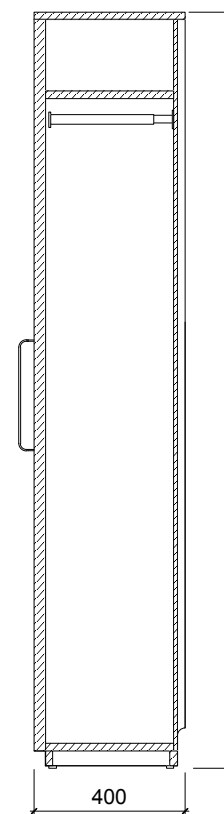

SNITT AA

UTTREKKBAR GARDEROBESTANG

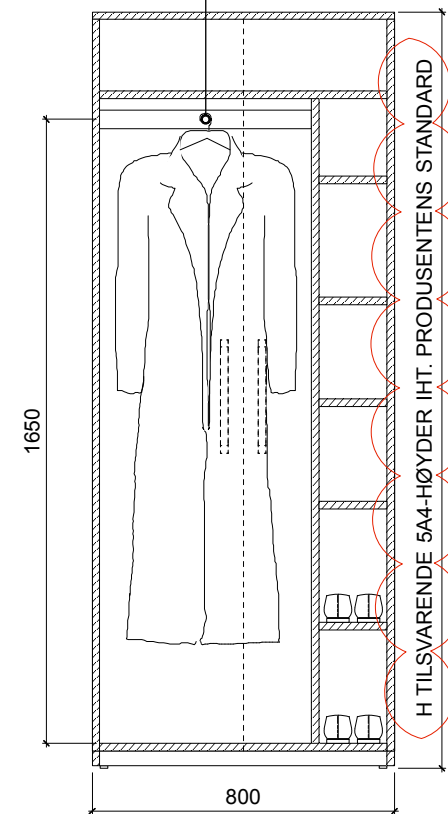

SNITT BB

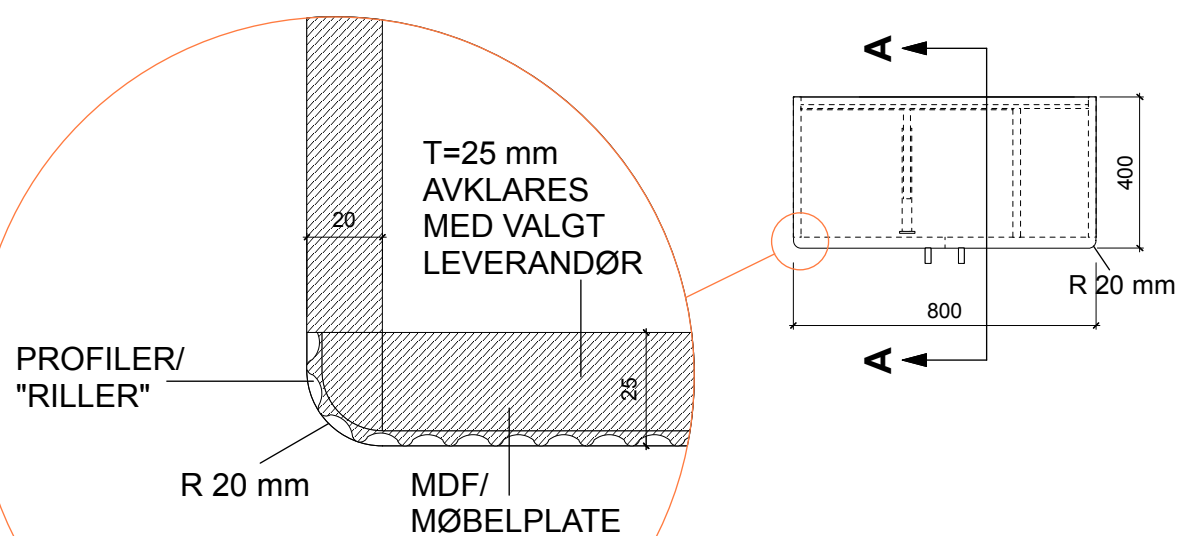

MED "RILLER" 1:2

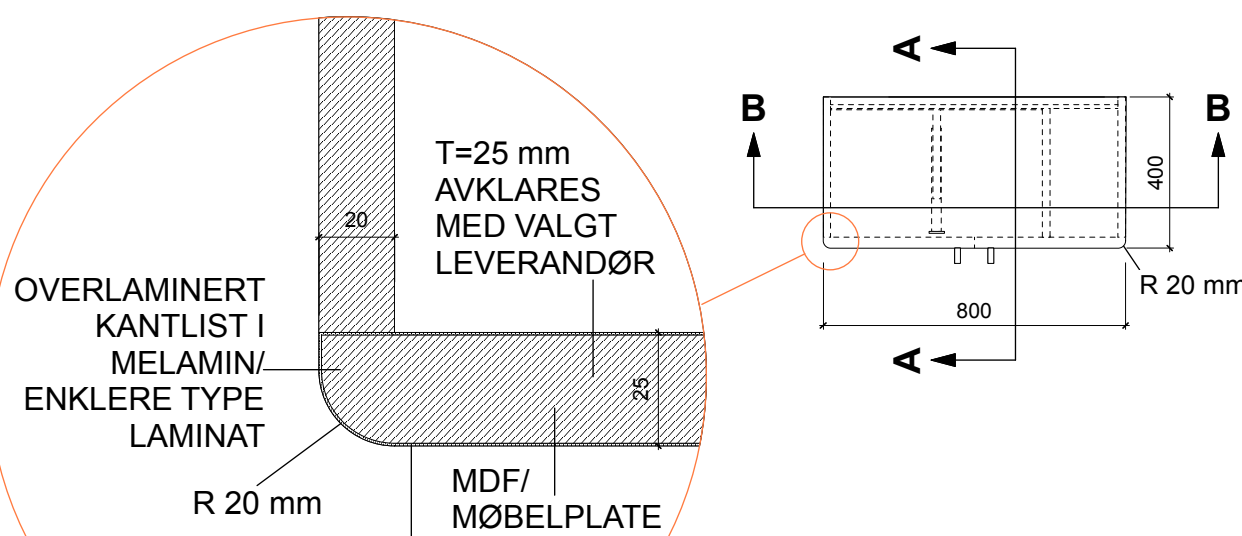
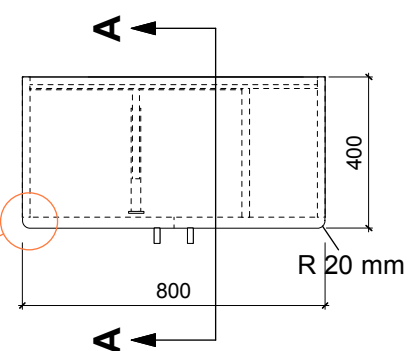

UTEN "RILLER" 1:2

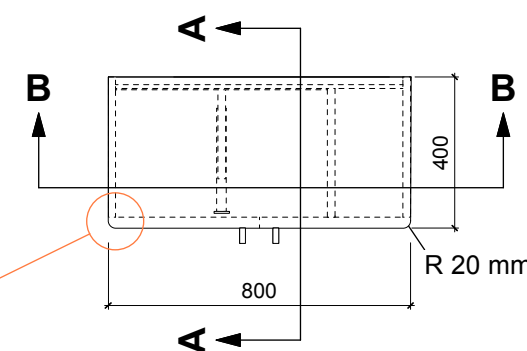

GARDEROBESKAP

03	29.05.2017	Revidert tekst ang. høyde til skap	SC
02	09.05.17	Endret type materiale, fra høytrykkslaminat til melamin/enklere type laminat	SC
01	05.05.17	Fjernet heitre kantlist	SC
Rev	Dato	Revidering	Sign

Prosj. nr. 1632 Byggesak Rammeavtale arbeidsplassmøbler

Byggherre **STORTINGET**

Tegning **GARDEROBESKAP**

Tegn.nr.

Disiplin	Tegningstype	Løpnummer	Status	Revisjon
I	T	19	F	03

Mål 1:20/1:2 @ A3

Dato	Sign.	Sign. KS
07.03.17	FMF	KG



Copyright • CADI AS

CADI AS • TLF 23274040 • E-POST eb@cadi.no

SKAP 2xA4 høyde med ÅPEN REOL OVER 3XA4 (uten riller)

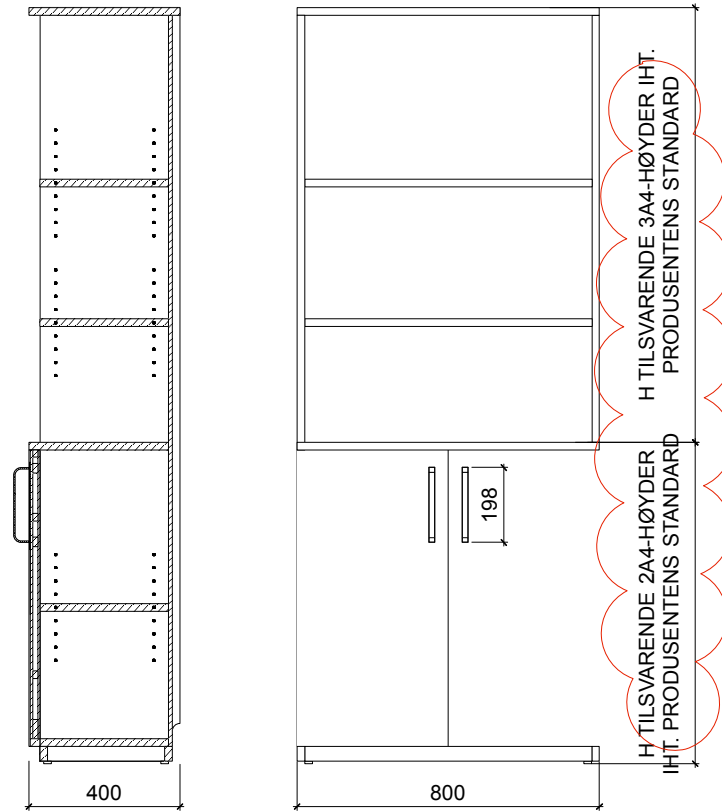

SNITT AA

OPPRISS FRONT

SKAP 3xA4 høyde med ÅPEN REOL OVER 2XA4 (uten riller)

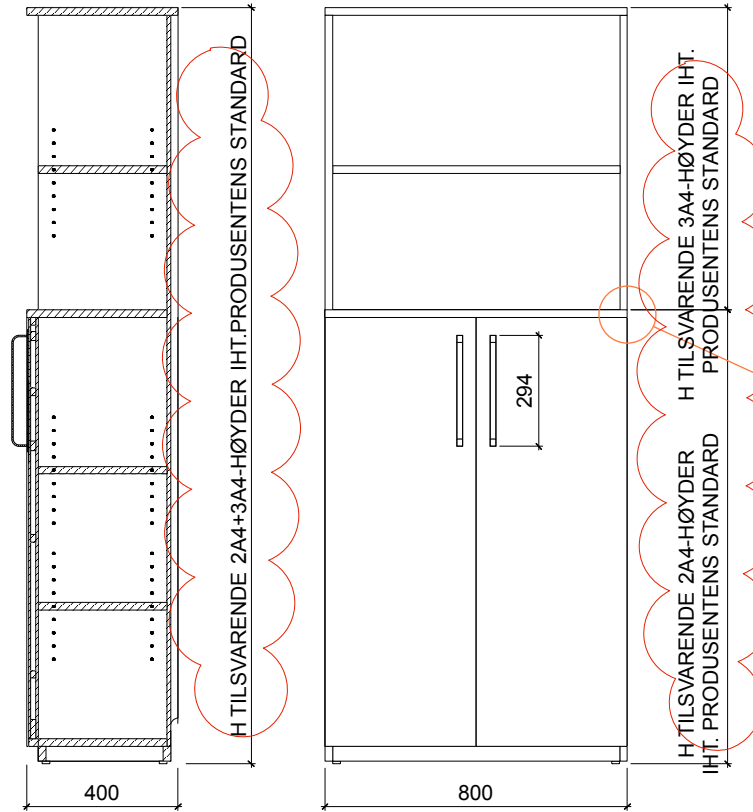

SNITT AA

OPPRISS FRONT

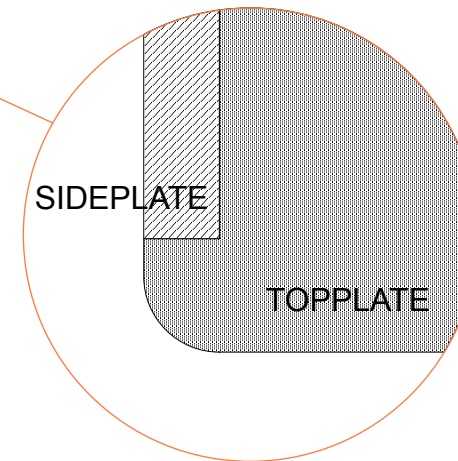

SKAP 2xA4 høyde med ÅPEN REOL OVER 3XA4 (med riller)

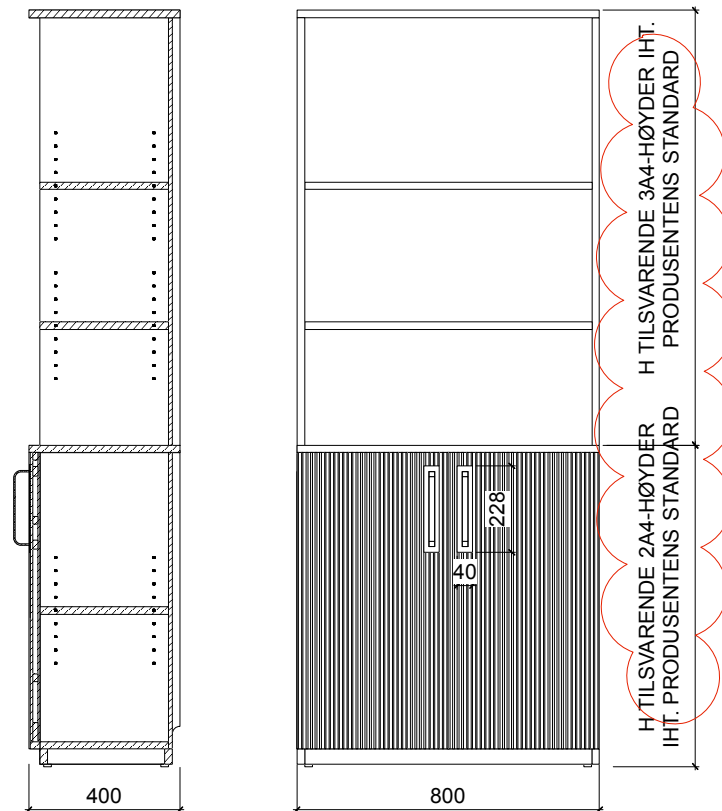

SNITT AA

OPPRISS FRONT

SKAP 3xA4 høyde med ÅPEN REOL OVER 2XA4 (med riller)

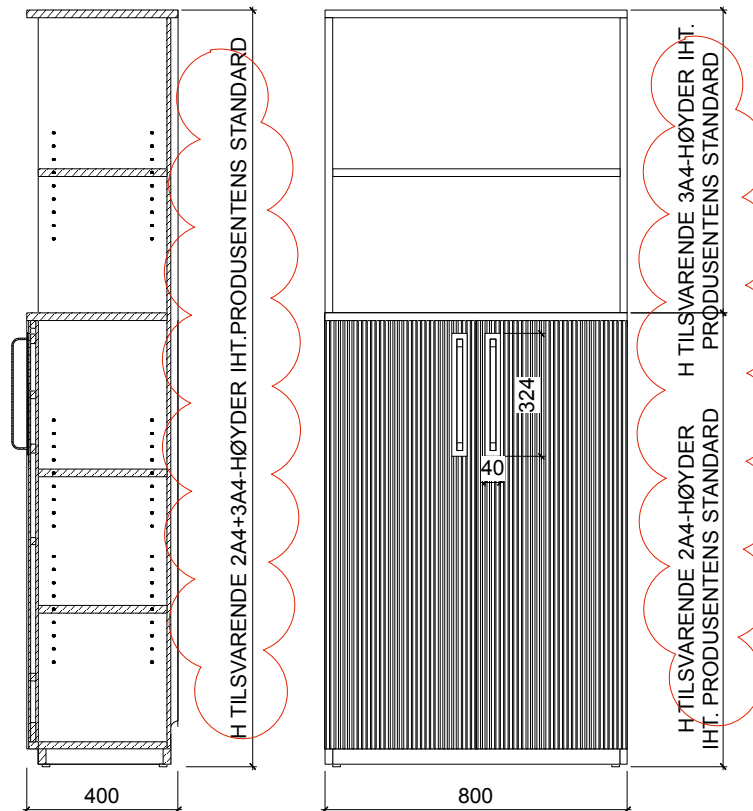

SNITT AA

OPPRISS FRONT

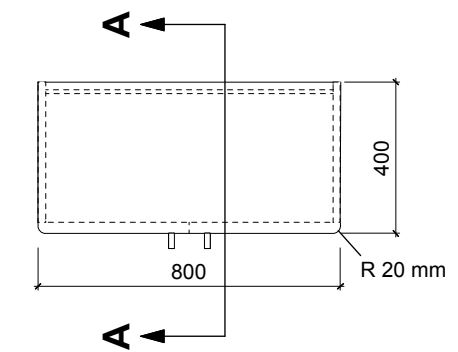

ÅPEN REOL

NB! ALLE MÅL MÅ KONTROLLERES PÅ STEDET!

01	29.05.2017	Revidert tekst ang. høyde til skap	SC
Rev	Dato	Revidering	Sign
Prosj. nr.	1632	Byggesak	Rammeavtale arbeidsplassmøbler
Byggherre	STARTINGET		
Tegning	ÅPEN REOL		
Tegn.nr.			
Disiplin	Tegningstype	Løpnummer	Status
I	T	20	F 01
Mål	1:20 @ A3		
Dato	16.03.17	Sign.	Sign. KS
		FMF	KG



Copyright © CADI AS

CADI AS • TLF 23274040 • E-POST eb@cadi.no