



HS Cooler
GmbH Wittenburg

Compact Heat Exchanger

Product Line K



INSTALLATION AND OPERATING MANUAL

Type : KS12-AEP-123 L800
Order No. : A10-9421
Serial No. : A10-9421A
Customer : Atlas Sales
CustomerNo. : Norsk Kulde 1000701-1

Table of Contents

GENERAL	4
Operational Range	4
Service	4
Guarantee	4
Conservation	4
Transportation	4
STRUCTURAL BUILD-UP	5
Tube bundle	5
Shell	5
Bonnets	5
Seals	5
Accessories/spare parts	5
SERVICE	6
Installation	6
Screw fasteners	6
Type plate	6
Starting up	7
Operating instructions	7
Switching off/standstill of the unit	7
MAINTENANCE	7
Periodic inspections	7
Dismounting	7
Assembly	8
Cleaning	8

TROUBLESHOOTING **9**

To low performance!/outlet temperature to high! 9

Leaky tubes! 9

Leaky rolling connection! 9

Leaky O-ring! 9

CONTACTS **9**

Cleaning 9

Repair/spare parts 10

APPENDIX

Type plate

Data sheet

Drawings

Parts list

INSTALLATION AND OPERATING MANUAL

FOR COMPACT HEAT EXCHANGERS OF PRODUCT LINE K

General

Operational Range

Heat exchanger of product line K were developed in particular for application in the field of the industrial and maritime cooling. The present device is a high efficient heat exchanger on the principle of shell and tube, in compact and lightweight design. The apparatus of this product line can be adapted to different conditions of use by particular combination of material and components. The field of application include all possible uses of cooling, in particular turbines, compressors, refrigeration units, hydraulic plants, in the range of engines, gears etc. Service life of the devices is essentially influenced by proper maintenance and operation. For this reason, observe strictly these instructions.

Service

For all service inquiries, please contact directly our factory, our sales force or your contracting party. In the case of spare part orders, please indicate always the designation of the device and/or the spare part. The necessary specifications can be taken from the enclosed drawings and from parts lists.

Guarantee

Warranty claims are to be taken from our general supply and payment terms, providing no other individual agreements were made.

Repairs of defective parts at a later stage may only be carried out with our approval. If circumstances should not permit asking our approval, you can ignore it. In this case you must inform us immediately at the nearest occasion.

In principal any changed service conditions must be approved by us in writing.

Conservation

Under normal conditions are internal surfaces of the devices protected for a duration of 6 months. A post-preserving is necessary after 6 months. The preserving liquid and the note on safety can be provided by us. The used preservative is well compatible with all mineral lubricants. The removal of these substances can be done by using any known solvent (check material compatibility!). The devices should only be stored in closed rooms. Condensation through strong variation of temperature must be avoided.

Transportation

A damage of the device must be by all means avoided. The transportation of the unpacked device when using lifting systems has to be carried out with sufficient number of transportation straps set around the casing. Please note the dead weight of the device indicated on the current data sheet or the type plate.

Structural build-up

Tube bundle

The tube bundle consists of two opposite identical tube plates with three grooves. The tubes are rolled into the tube plate wholes. Between the tube plates at the outer side of the tubes, the surface is enlarged forming fins which are in connection with the tubes. The result is a compact finned bundle. At the outer side of the finned bundle, there are grooves across the whole length which are used to take up sealing straps. In the finned bundle, a different number of baffles can be installed. A groove is milled in the top of the baffle which contains a spring and a sealing plate. The interior O-ring grooves in the tube plates seal against the casing in assembled state. The external seals are used for sealing the bonnet. In this way, a intermixing of the media is avoided if a seal becomes defective and a leakage localization is simplified. In the central groove, sheets are positioned which fix the tube plate in assembled state and allow a thermal expansion for the opposite tube plate. With two path devices, the fixation must be at the side of the connections. In any case, the side of fixation is marked by an imprinted 'F' at the flange of the casing in the area of the flanges M1 or M2. The fixation must be positioned at this side when in working condition.

Shell

The shell is used for taking up the tube bundle and forms the shell side casing. It consists of end pieces which are circular-welded with the shell tube. The end pieces can be placed in such a way that the connections are positioned at one side or rotated by 180°. The shell tube is a precision tube with restricted allowances.  Changes must not be carried out on the casing. At the starting area of the end pieces, the interior groove of the tube plates seals by means of an O-ring. This area must be treated carefully in order to guarantee a sealing effect. The mounting brackets grip around the shell tube. These allow an optional assembly position of the device.

Casings of model KK are cast casings in standardized, fixed version.

Bonnets

The bonnets consist of different materials (see part list), depending on version of the device. The bonnet forms together with the tube bundle the chamber of the cooling medium and is fixed to the casing by screws. At one side of the device, sheets are inserted between bonnet and casing which fix the tube plate. At the other side, washers form a spacer.

The one path version has two identical bonnets positioned opposite each other. With the two path version, one bonnet with two connections is mounted at one side of the device, at the other side there is a reversing cover. To separate the two chambers in the bonnet, a plastic or aluminium path partition is inserted into the tube plate at the connection side. In assembled state, the path partition seals bonnet and tube plate, i.e. it splits the flow of tubeside medium through the device.

Seawater resistant versions contains sacrificial anodes.

Seals

All tube plate seals consist of O-rings.

All pipe threads are sealed by copper or aluminum rings.

The tube bundle is sealed at the side along its length with a sealing strip against the casing. The sealing strips consist of the same material as the O-rings. All seals are available from our factory with indication of the drawing number.

Accessories/spare parts

Accessories and spare parts can be taken from the enclosed drawings and part lists. Drawing and identification numbers of components which are necessary for ordering, are also listed there. Price lists for the spare parts and not listed accessories can be requested via our marketing department or directly from factory.

Service

Installation

The following items must be considered during the installation of the device:

- Protective caps fitted to connections must be removed. If there is no protective cap on a connection, check whether it has been pushed into the connection or foreign parts have penetrated the device.
- Foreign bodies must not penetrate the openings of the connections.
- The connection of the pipes must be tension-free to ensure that no inadmissibly high thermal or mechanical tensions affect the device in service.
- All circuits must be designed to avoid penetration of dirt and dust. We recommend the assembly of dirt traps and suitable filters.
- Tubes must be correctly installed so that air locks cannot built up.
- The assembly can be horizontal or vertical.
- Sufficient space should be available to ensure easy accessibility to all screw connections. Take particular care for providing enough space for remove the tube bundle. You can take the necessary space dimensions for remove the tube bundle from the sketch. It is possible to remove the tube bundle from both sides of the device.
- . The direction of flow is to be taken from the enclosed sketch and from the datatsheet
- Before startup, the device must be completely bled.
- Never weld or modify the cooler.
- In case of using the device as oilcooler before startup, clean/flush the oil circuit but not the lubricated points.
- Orifice plates must only be installed at the outlet side of the device.



Screw fasteners

To ensure a safe operation and a long service of fastening elements, the screw fastenings should be only torqued. The table below lists the torque figures for used screws. Through influence of various factors, the specified values may show a deviation which in individual cases require lower or higher values.

Connection shell/bonnet

type	screw/ strength	torque [Nm]
K12	M12 5.6	38
	M12 8.8	80
K20	M16 5.6	95
	M16 8.8	200
K25	M20 5.6	180
	M20 8.8	400



Connection flanges

screw/ strength	material of thread	torque [Nm]
M12 5.6	aluminium	30
	red bronze	30
M16 5.6	aluminium	75
	red bronze	75
	cast steel	100
M24 5.6	cast steel	300

Type plate

The type plate is at the side of the device and is permanently fixed. You can find a copy of the type plate in the appendix.

Starting up

At first the apparatus must be filled up with the intended medium, then the entire system must be checked for leakage. For watercooled devices use only clean water at the tube side. Before the actual starting up of the system,  make sure that the cooling medium is circulated. Operating the device without flow of  cooling medium is not permissible.

Only for watercooled units:

If the flow adjustment is carried out by a control, we recommend a oil-sided control, especially when operating with river or sea water.

Discuss the control of cooling water with our factory, because factors like material and quality of cooling water are very important to avoid later problems.

The use of additives in the cooling water has to be confirmed through HS-Cooler GmbH.

Operating instructions

During the operation, make  sure by suitable means that pre-set parameters for which the devices are designed are kept.

If reserve devices with switch- over valves are present, switch these devices periodically on (all 2-3 days) or load the reserve device daily for some time with the full water volume.

Switching off/standstill of the unit for watercooled units

With a short-term standstill (<4 days) of the unit, the apparatus can remain filled.



When switching off the unit, the water must be removed. In the case of operating the device with sea water or aggressive water, flush the unit additionally with clean water. The tube bundle should as far as possible be dried inside with compressed air. Further, if a drainage is not possible, then a flow of the correct amount of cooling water must be maintained.

Maintenance

Periodic inspections

Devices of product line K are normally reliable and easy to maintain. However, some periodic inspections of the device are necessary to provide a safe, continuous operation. Normally inspections on the tubeside (waterside) predominate. The shellside is less inclined to pollution so that an inspection can be carried out based on the experience of the operator.

The following inspections should be practiced:

- When operating with sea water, sacrificial  anodes are installed in the bonnets/covers. These should be checked  in the initial phase all 3 months. If the anodes are used up, they must be  replaced by new ones. In the case of excessively fast consumption of the anodes, water quality and the electrical potential of the system must be checked.
- The device should be cleaned at the water side at least once a year. An excessive pollution of the tubes must by all means be avoided. The bonnets can be removed without depressurizing the shell side. The intervals are to be shortened during long ship operation in harbors or in other polluted waters and depending on the experience of the operator.
- At shorter intervals the device must be subject to an externally visual inspection, in order to identify leakage or other problems early. Through the double O-ring sealing, leakages can be precisely located and the relevant expenditure can be estimated.

Dismounting

Proceed as follows when dismantling the apparatus:

- Lock-up any pipelines
- Empty the apparatus at the tube side, if a removal of the tube bundle is necessary, empty also the shell side.
- Remove the pipelines at the tube side.
- Remove the bonnets/covers. For this purpose, the screws at the bonnet/casing connection must be loosened. Between the bonnet/cover there are 4 fixing plates or washers. These must be

replaced at the same side again during re-assembly. The marking on the casing flange must be here observed.

- If you want to dismount without remove the tube bundle, the bonnet/cover without order to protect the tube bundle against displacement, before you remove the fixing plates. This can be done with another set of fixing plates or with similar aids.



Dismounting without remove the tube bundle:

- Remove the O-rings from the external groove of the tube plates and secure the tube bundle to the casing with four screws and the four fixing plates in the middle groove of the tube plates. The tube side can now be inspected and cleaned mechanically. The shell side can remain under pressure.

Dismounting with remove the tube bundle:

- Remove the O-rings from the external groove of the tube plates. At one tube plate, a marking of the fixed position in relation to the casing is attached. A half of a 'X' is stamped at the front of the tube plate and the adjacent casing flange. Check the position of the marking. Push the tube bundle (where appropriate with auxiliary tools) so far sideways until the O-ring of the interior groove becomes visible. Remove the O-ring from the interior groove. Pull out the tube bundle in the opposite direction. Remove the tube bundle carefully from the casing without damaging the fins. As far as possible suspend the tube bundle with the help of large-surface transportation straps. The grooves taking the O-rings must not be damaged. During dismounting of the tube bundle the sealing plate and the spring can drop out of the baffle groove. The spring and the sealing plate have to be installed during assembly of the bundle by pressing them into the groove whilst the baffle passes the inlet of the shell.
- When dismounting vertically fixed devices, make sure does not slips down after removal of the fixing plates. We recommend to provide an additional set of fixing plates and to start the removal at the side where no fixing plates are mounted. There the bundle must be secured first. After dismounting the second bonnet, the bundle can be removed carefully. While assembling, only one set of fixing plates is permitted at the side of the marking.



Assembly

The assembly is carried out in reversed order as dismounting. The following must also be considered:

- Generally use new O-rings and clean O-ring grooves.
- Note the marking for proper assembly of the tube bundle (X).
- Note the marking for correct assembly of the fixing plates (F).
- At the side of the tube bundle there are sealing straps. These should only be replaced when damaged. When pushing-in the tube bundle take care that the sealing straps are not displaced or twisted. Before assembling the tube bundle, the sealing straps should be greased. You can use the operating medium. The sealing straps must be effective along the entire length of the tube bundle.
- Insert the sealing plate and the spring into the baffle groove and press down during insertion of the tube bundle
- Lubricate O-rings with suitable O-ring grease.
- During insertion of the tube plate into the sealing faces, make sure that the O-rings do not shear. The bonnets/covers must be set up in parallel onto the tube plate and must be pushed evenly onto the O-ring; ensure also that the O-ring does not shear.
- With two path devices, a path partition must be fitted at the side of the bonnet with the two connections. At this side, the fixing sheets must also be installed later.
- When assembling the two path bonnet, make sure that the path partition is correctly placed.
- Then continue as described under 'Operation'.



Cleaning

In the case of only small amount of fouling, the tube side can be mechanically cleaned. Disassemble the device as described under 'dismounting without remove the tube bundle' and clean with a suitable nylon brush (do not use metal brushes) each tube inside, then clean with water. Never remove stuck deposits or coarse dirt by force.



In the case of stuck deposits, the tube bundle must be cleaned chemically. This can be carried out by rinsing the tube in the assembled state or submerging in disassembled state. Such a cleaning must only be practiced by specialists. Only suitable solvents must be used. To select a suitable agent, refer to the added part list. Take the materials of the plastic separator strip and O-rings in the assembled state into consideration. Under 'Contacts' you find some companies offering respective agents or carrying out a complete cleaning.

Provided that the type designation gets a C at the 11th position (example: KS12-BCN-821**C** L1000), then it is a coated tube bundle. To prevent a damage caused by corrosion this bundle is coated on the inside of the tubes and on the tubesheets. When dismantling the bundle and during cleaning make sure that the coating will not be damaged or destroyed. Use only nylon cleaning brushes and approved cleaning agents. If there are any doubts about suitability of an agent, please contact our service department.

Troubleshooting

To low performance!/outlet temperature to high!

- Check all temperatures and material flows in accordance with the design data?
- Are foreign bodies in pipe or in device causing obstruction?
- Is the tube bundle correctly assembled, check marking?
- Are the path partition and the fixing plates correctly assembled in the two path bonnet?
- Are all pressure rooms vented?
- Are tube side or shell side too dirty (too thick deposits)?
- Are more than 10% of the tubes plugged?

Leaky tubes!

If the presumption exists that tubes have become leaky, proceed as with 'dismounting without remove the tube bundle'. The shell side can remain under pressure. After cleaning the tube plates, you can identify the defective tube by the state of the emerging medium. Lock the leaky tube at both ends with our 'Tubelock'-Repairset. Alternative you can use a conical copper or aluminium plug or a conical hard wood plug. The plug must not be pushed too strong since otherwise adjacent rolling connections can be damaged. You can lock 10% of the tubes at the most without noticeable reduction in performance. Dismounting the defective tube is not possible.

Leaky rolling connection!

If it is found during the check for leaky tubes that a rolling connection is leaky, it can be rolled again with a specific rolling tool. This work however is only to be carried out by specially trained personnel. Since defects of this type are uncommon, a check of the complete bundle in our factory is recommended.

Leaky O-ring!

If a leakage is found between bonnet/cover and casing, an O-ring of the tube plate is defective. The kind of the emerging medium defines at which groove of the tube plate the defect developed. In the case of a defect on the tube side, proceed as described under 'dismounting without remove the tube bundle'. In the case of a defect at the shell side, proceed as described under 'dismounting with withdrawing the tube bundle'. In this case the tube bundle does not need to be removed completely from the casing. Assemble the O-ring as described in 'Assembly'.

Contacts

Cleaning

Suppliers for cleaning agents:

- Ashland Chemicals – www.ashchem.com

- Henkel Oberflächentechnik- www.henkel.com
- Ondeo Nalco – www.ondeo-nalco.com

Contractors for complete cleaning

- Vecom – www.vecom.nl
- - Ondeo Nalco – www.ondeo-nalco.com

Repair/spare parts

Repairs must only be carried out by specially trained personnel. However we recommend to carry out any repair in our factory.

You can purchase spare parts directly from us with indicating the sketch and serial number. Please contact our head offices or our sales office.

HS-Cooler GmbH Wittenburg is not liable for any defect resulting from any adverse use of the product.

We reserve the right to adapt this operating manual at any time without prior notice to include the latest developments.

 - Ergänzung zu Kapitel ‚Wartung/Demontage/Demontage ohne Herausziehen des Rohrbündels‘. Bei Zusammenbau müssen die Fixierplatten wieder an der richtigen Seite des Wärmetauschers eingebaut werden - siehe dazu die Bedienungsanleitung!

 - Addition to chapter ‚Maintenance/Dismounting/Dismounting without remove the test bundle‘. During assembly the fixing plates have to be assembled to the correct side of the heat exchanger – see the instruction manual!

 - En complément du chapitre « maintenance/démontage/démontage sans tirer vers l'extérieur le faisceau tubulaire ». Lors de l'assemblage les dalles de fixation doivent être encastrées dans le côté exact de l'échangeur de chaleur - voir à cet effet l'instruction d'exploitation.

 - Complemento al capítulo “Mantenimiento/Desmontaje/Desmontaje sin extraer el haz de tubos”. Al realizar el montaje, las placas fijadoras se han de volver a colocar en el lado correcto del intercambiador de calor - ver para ello las instrucciones de servicio.

 - Completamento del capitolo ‚Manutenzione/Smontaggio/Smontaggio senza estrazione del fascio tubolare‘. Nella fase di assemblaggio, le piastre di fissaggio devono essere rimontate sul corretto lato dello scambiatore di calore – vedi a questo proposito le istruzioni per l'uso!

 - Suplemento do capítulo “Manutenção/Desmontagem/Desmontagem sem extração do feixe de tubos”. No momento da montagem, as placas de fixação deverão ser outra vez aplicadas no lado correcto do permutador térmico -- consulte o manual de instruções!

 - Aanvulling bij het hoofdstuk ‚Onderhoud/demontage/demontage zonder uittrekken van de buizenbundel‘. Bij de montage moeten de fixeerplaten opnieuw aan de correcte zijde van de warmtewisselaar worden ingebouwd – zie ook de gebruiksaanwijzing!

 - Komplettering av kapitel ‚Skötsel/demontage/demontage utan att dra ut rörpaketet‘. Vid sammansättningen måste fixerplattorna åter monteras på rätt sida av värmeväxlaren - se bruksanvisningen om detta!

 - Supplement til kapittel ‚Vedlikehold/demontering/demontering uten uttrekking av rørbunt. Ved sammensetting må posisjoneringsplaten monteres på korrekt side av varmeveksleren - se bruksveiledningen!

 - Täydennys lukuun ‚Huolto/Purkaminen/purkaminen ilman putkinipun ulosvetämistä‘. Koottaessa on kiinnityslevyt asennettava taas oikein lämmönvaihtimen sivulle – katso käyttöohje!

 - Дополнение к главе ‚Техобслуживание/демонтаж/демонтаж без выдергивания пучка труб‘ - При сборке все фиксирующие пластины должны монтироваться в правильной стороне теплообменника – смотри касательно этого инструкции по эксплуатации!

 - Uzupełnienie do rozdziału ‚Konserwacja/Demontaż/demontaż bez wyciągnięcia wiązki rurowej‘. Przy montażu, płyty ustalające muszą zostać znowu wbudowane po właściwej stronie wymiennika ciepła – patrz: Instrukcja obsługi!

 - Dodatek k poglavju ‚Vzdrževanje/Demontaž/demontaž brez izvlačenja snopa cevi‘. Pri sestavi je potrebno fiksne ploščice spet vgraditi nazaj na pravilni strani toplotnega izmenjevalnika – glejte k temu navodila za upravljanje!

 - Dodatek ku kapitole ‚Udržba/demontáž/demontáž bez vyťahovania zväzku trubiek‘. Pri montáži je potrebné fixačné dosky znovu namontovať na správnu stranu výmenníka tepla – pozri v tejto súvislosti návod na obsluhu!

 “维护/拆卸/不移走管束的拆卸”一章的补充
在安装过程中，固定片必须重新安装在热交换器正确的一面—见使用说明书中的相关说明。

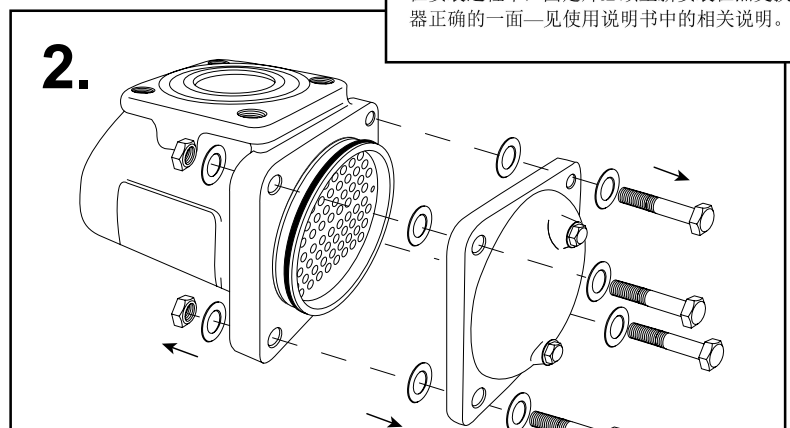
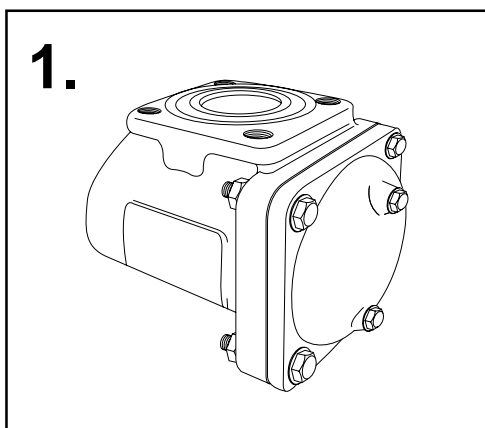
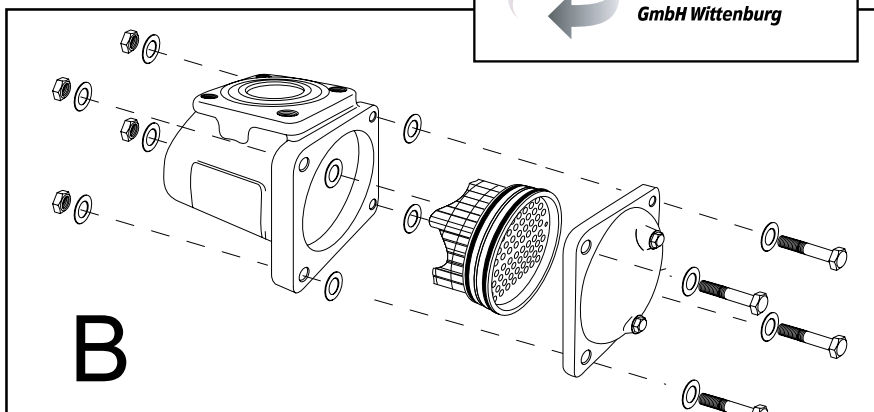
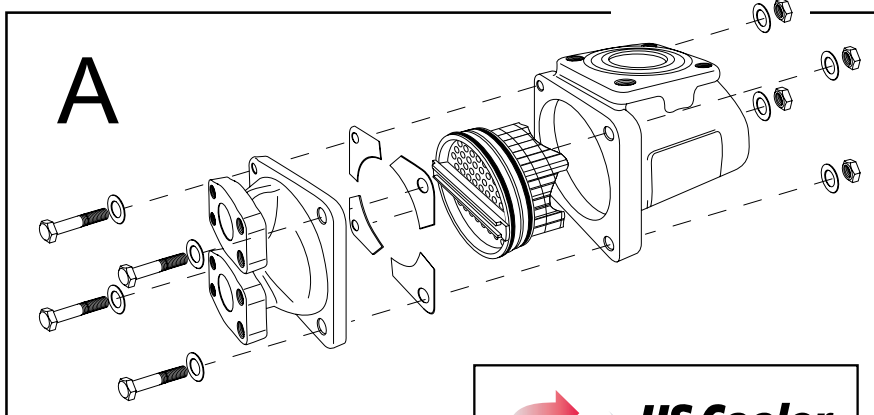

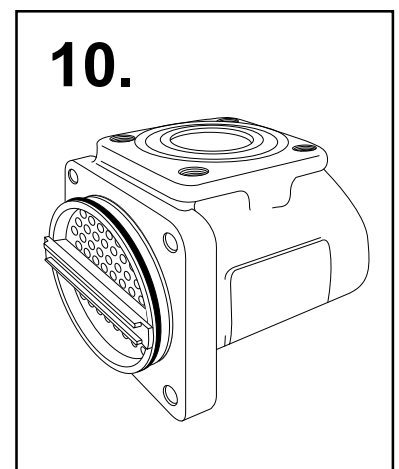
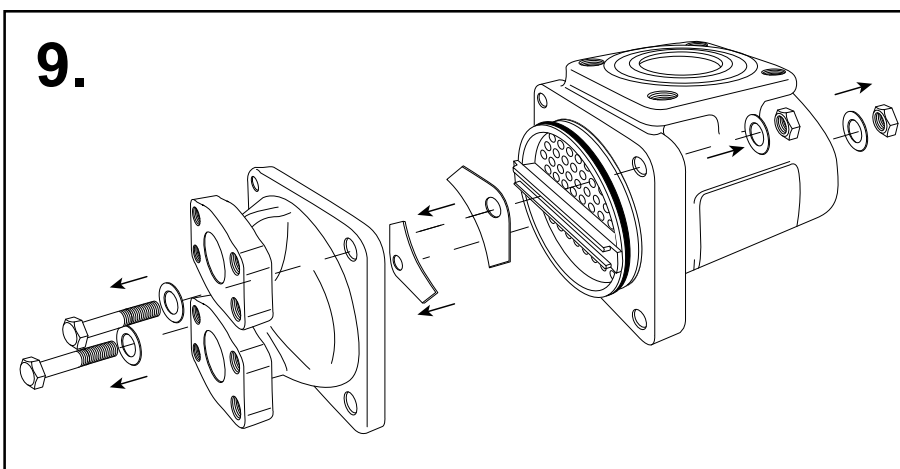
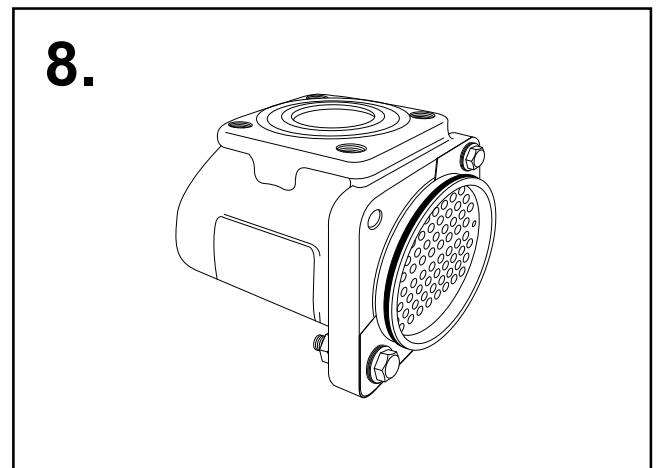
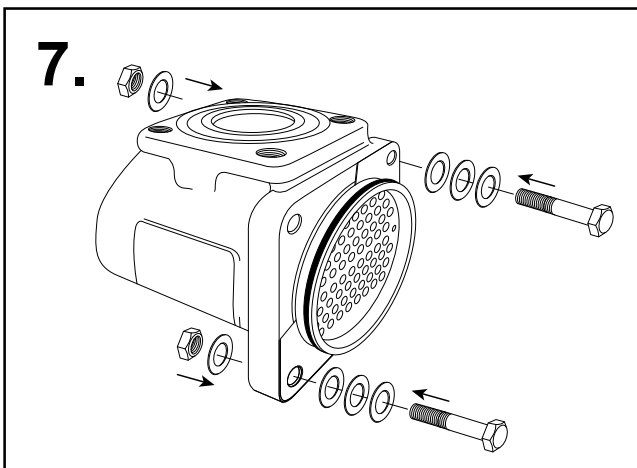
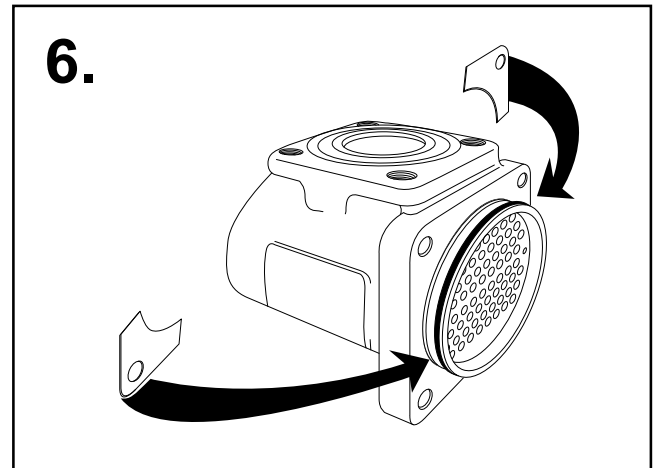
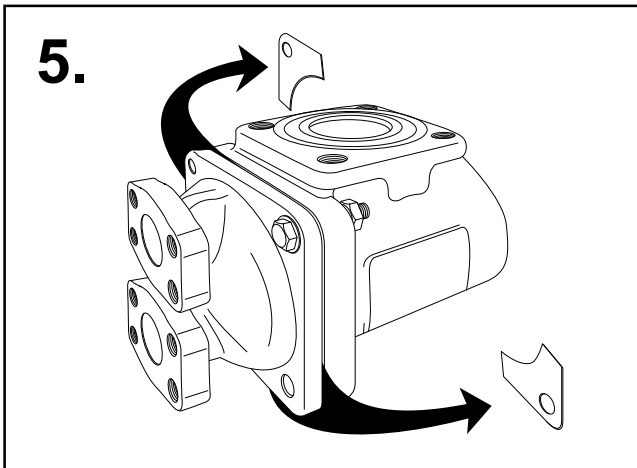
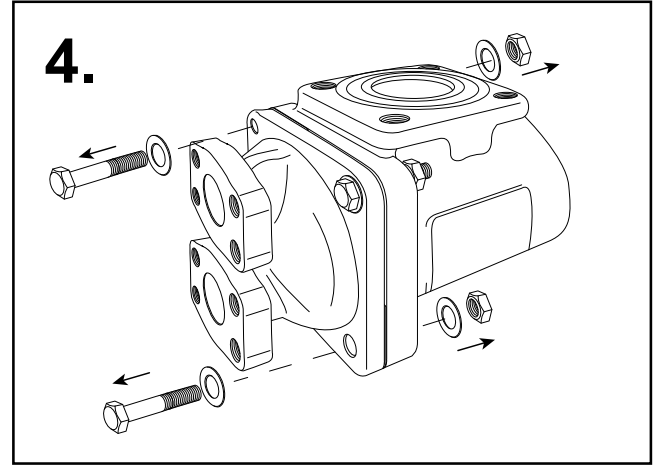
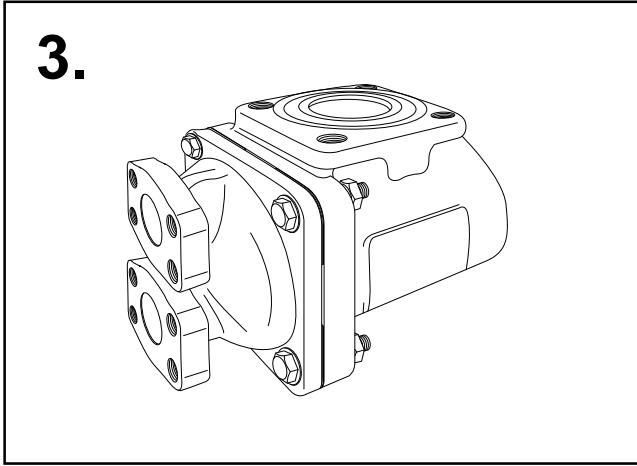



 - Ergänzung zu Kapitel ‚Wartung/Demontage/Demontage ohne Herausziehen des Rohrbündels‘. Konstruktiver Aufbau der Wärmetauscher KS## - F## - #2# abweichend von der Standard Ausführung. Vor dem Öffnen des Wärmetauschers unbedingt beide Druckräume komplett entleeren!

 - Addition to chapter ‚Maintenance/Dismounting/Dismounting without remove the test bundle‘. The constructive design of the heat exchangers KS## - F## - #2# is different from the standard version. Always completely drain both pressure chambers prior to opening the heat exchanger.

 - En complément du chapitre « maintenance/démontage/démontage sans tirer vers l'extérieur le faisceau tubulaire ». Montage constructif des échangeurs de chaleur KS ## - F## - #2# divergent par rapport à la version standard. Avant l'ouverture de l'échangeur de chaleur, il est obligatoire de vider complètement les deux chambres de compression!

 - Complemento al capítulo “Mantenimiento/Desmontaje/Desmontaje sin extraer el haz de tubos”. La estructura constructiva del intercambiador de calor KS## - F## - #2# difiere del modelo estándar. Antes de abrir el intercambiador de calor, es imprescindible vaciar completamente los dos compartimentos de presión.

 - Completamento del capitolo ‚Manutenzione/Smontaggio/Smontaggio senza estrazione del fascio tubolare‘. Struttura dello scambiatore di calore KS## - F## - #2# differente dal modello standard. Prima di aprire lo scambiatore di calore, svuotare assolutamente in modo completo entrambe le camere di pressione!

 - Suplemento do capítulo “Manutenção/Desmontagem/Desmontagem sem extração do feixe de tubos”. Disposição construtiva do permutador de calor KS## - F## - #2# diferente do modelo standard. Antes de se abrir o permutador de calor as duas câmaras de pressão devem ser completamente esvaziadas!

 - Aanvulling bij het hoofdstuk ‚Onderhoud/demontage/demontage zonder uittrekken van de buizenbundel‘. Constructie van de warmtewisselaar KS## - F## - #2# afwijkend van de standaarduitvoering. Voor het openen van de warmtewisselaar in ieder geval beide drukkamers compleet leegmaken!

 - Komplettering av kapitel ‚Skötsel/demontage/demontage utan att dra ut rörpaketet‘. Den konstruktiva uppbyggnaden av värmväxlare KS## - F## - #2# avviker från standardutförandet. Innan värmväxlaren öppnas, måste ovillkorligen de båda tryckkammarna tömmas komplett!

 - Supplement til kapittel ‚Vedlikehold/demontering/demontering uten uttrekking av rørbunt. Konstruktiv oppbygging av varmeutveksleren KS## - F## - #2# avviker fra standard-utførelsen. Før varmeveksleren åpnes må begge trykkrommene tømmes helt!

 - Täydennys lukuun ‚Huolto/Purkaminen/purkaminen ilman putkinipun ulosvetämistä‘. Lämmönvaihtimien KS## - F## - #2# rakenne vakiomallista poikkeava. Ennen lämmönvaihtimen avaamista on kumpikin painekammio ehdottomasti tyhjennettävä täydellisesti!

 - Дополнение к главе ‚Техобслуживание/демонтаж/демонтаж без выдергивания пучка труб‘ - Конструктивное устройство теплообменника KS## - F## - #2# отклоняется от стандартного исполнения. Перед тем, как открывать теплообменник, обязательно полностью опорожнить обе камеры нагнетания!

 - Uzupełnienie do rozdziału ‚Konserwacja/Demontaż/Demontaż bez wyciągania wiązki rurowej‘. Konstrukcja wymienników ciepła KS ## - F## - #2# różni się od wykonania standardowego. Przed otwarciem wymiennika ciepła bezwarunkowo opróżnić całkowicie obydwa komory ciśnieniowe!

 - Dodatek k poglavju ‚Vzdrževanje/Demontaža/demontaža brez izvlačenja snopa cevi. Konstruktivna izgradnja toplotnih izmenjevalnikov KS## - F## - #2# ni enaka standardni izvedbi. Preden boste toplotni izmenjevalnik odprli, obvezno izpraznite oba tlačna prostora!

 - Dodatek ku kapitole ‚Údržba/demontáž/demontáž bez vytáhovania zväzku trubiek‘. Konštrukčná stavba výmenníka tepla KS## - F## - #2# je odlišná od štandardného prevedenia. Pred otvorením výmenníka tepla bezpodmienečne vyprázdňte obidva tlakové priestory!

 “维护/拆卸/不移走管束的拆卸”一章的补充 热交换器 KS##-F##-#2# 系列产品的结构设计, 不同于标准设计。在打开热交换器前, 必须彻底排空两个压力室!

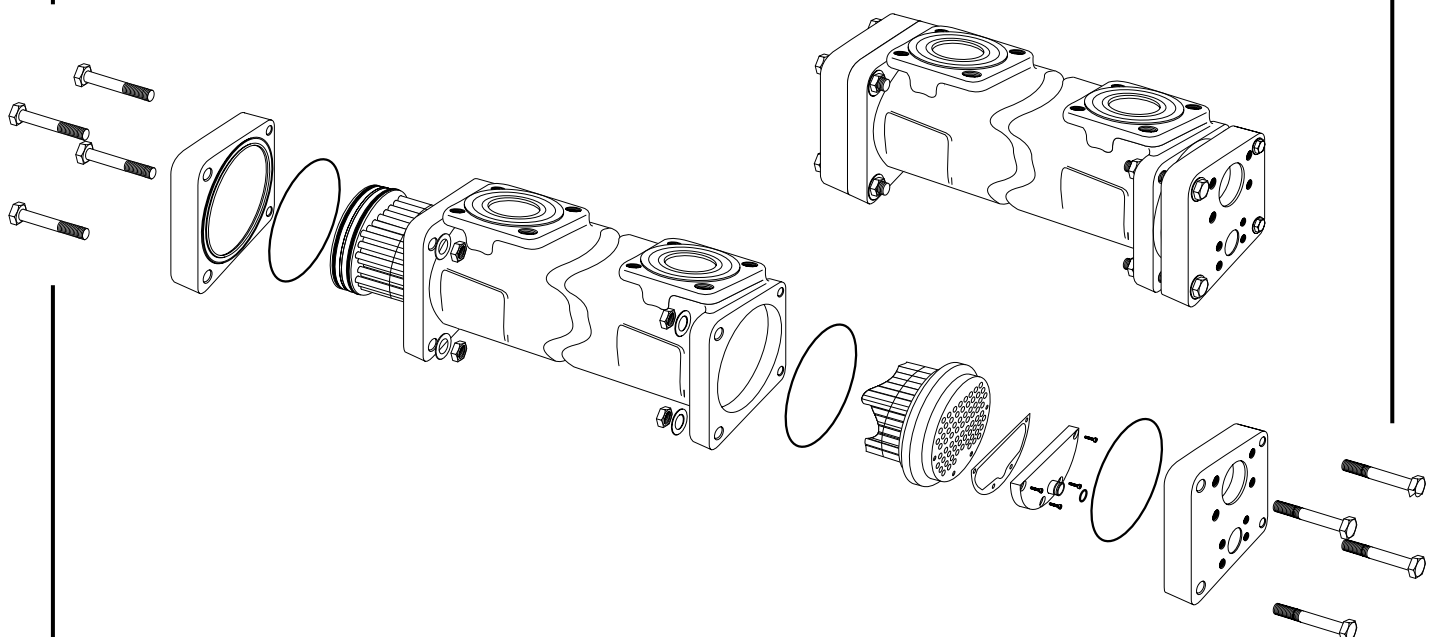

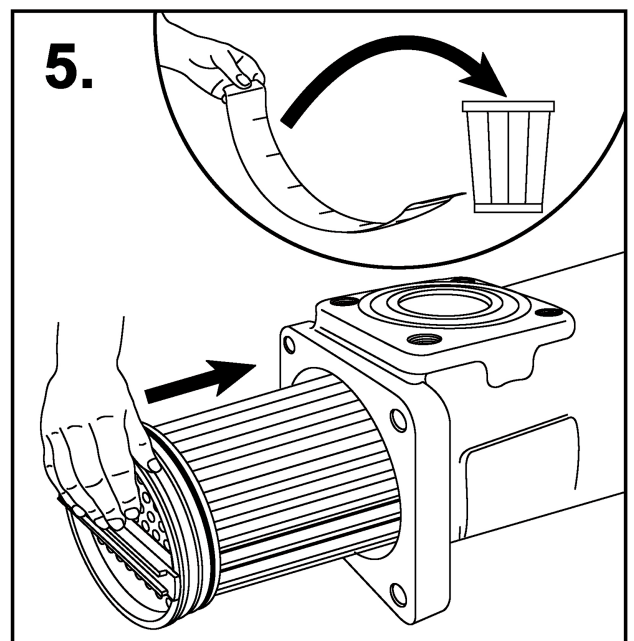
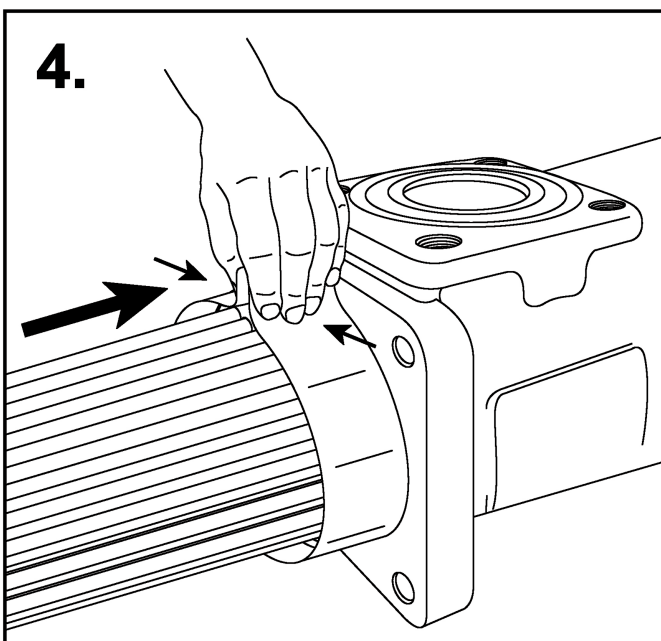
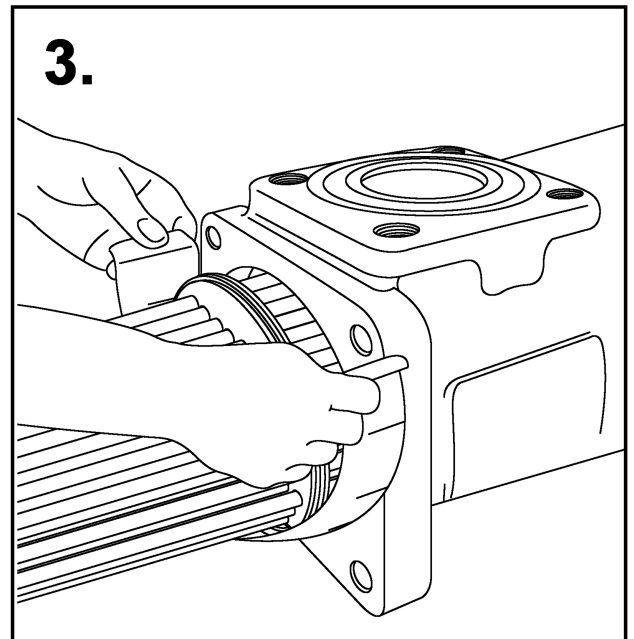
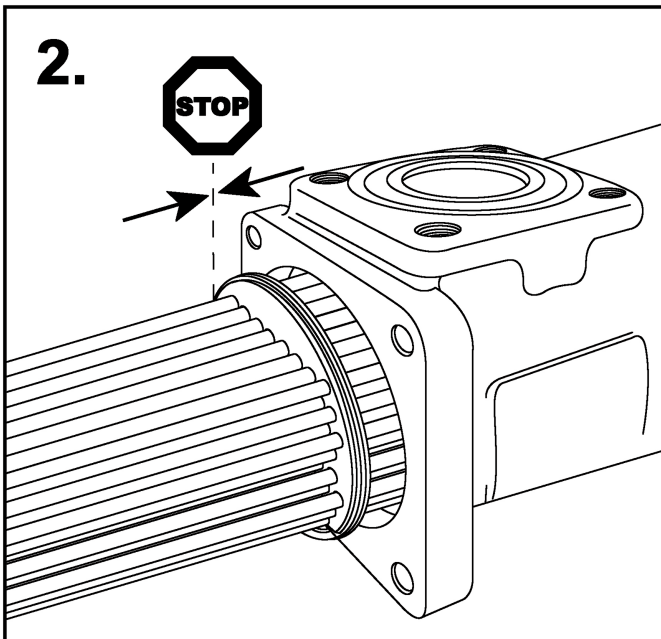
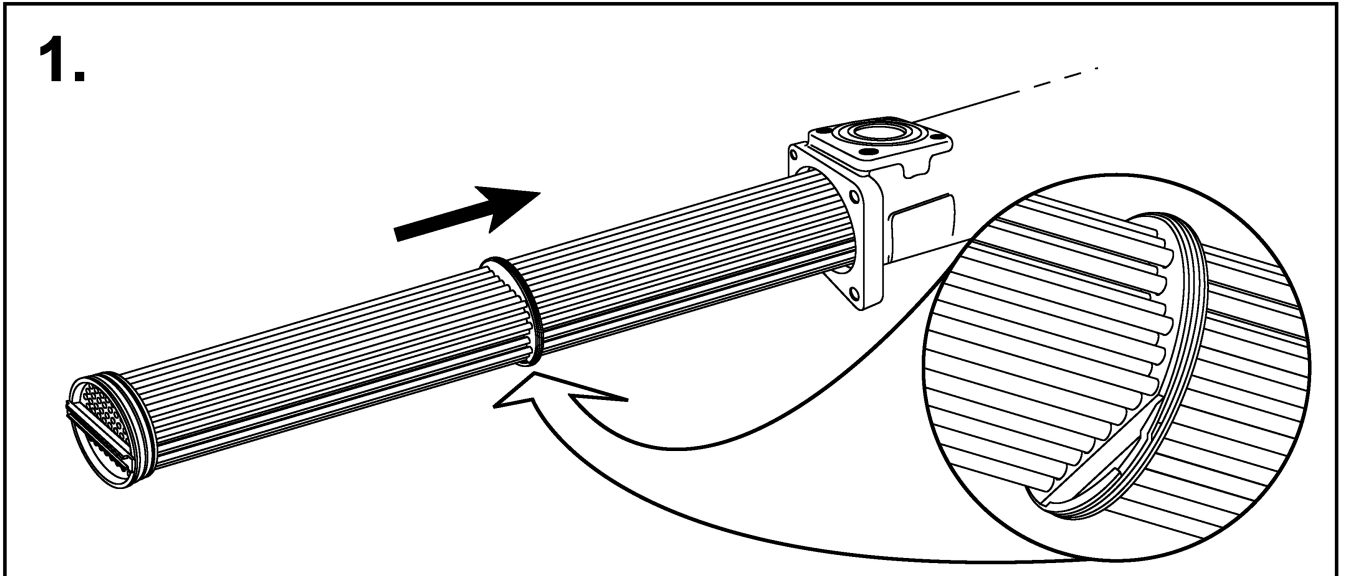

Customer	NORSK KULDE	Date	01.07.2010
Reference	1000701-1	Offer No.	B10-12440
Type	KS 12 - A E P - 1 2 3 - L800	Pressure range	Y
Medium		<u>Shellside</u> ISO VG 68 + NH3	<u>General</u> <u> Tubeside</u> Water
Heat capacity	kW		75
Inlet temperature	°C	83	38
Outlet temperature	°C	60	46,2
Volume flow	m ³ /h	6,8	8,0
Pressure drop	bar	0,27	0,11
Active surface	m ²	10,42	1,27
Max. temperature	°C	100	100
Max. pressure	bar	30	10
Fouling	m ² K/kW		0
Extra capacity	%		20
Shell diameter	mm		139,7
No. of baffles	-		3
No. of tubes	-		72
Tube diameter	mm		8,0 x 0,5
Bundle length	mm		800
Paths tubeside	-		2
Weight(e)	kg		41
Contents	dm ³	6,5	3,6
Tubes	-		<u>Material</u> 1.4404
Tubesheets	-		1.4301
Fins	-		Aluminium
Baffles	-		Aluminium
O-rings	-		NEOPRENE
Bonnets/cover	-		GG25
Shell	-		Steel
Connections	-	DN50	SAE11/2"/BSP11/4"
Remarks	---		

Primer:
2-Component-Epoxy Resin
Dry Film Thickness 40-60µm

approved pressures and temperatures for ABS/BV/DNV/GL/LRS/RS/RINA/TÜV:				
Pressure range	Shellside		Tubeside	
	X	Y	X	Y
max.operating pressure(bar)	16	25	10	10
test pressure(bar)	24	37,5	15	15
max.operating temperature(°C)	130	100	100	100

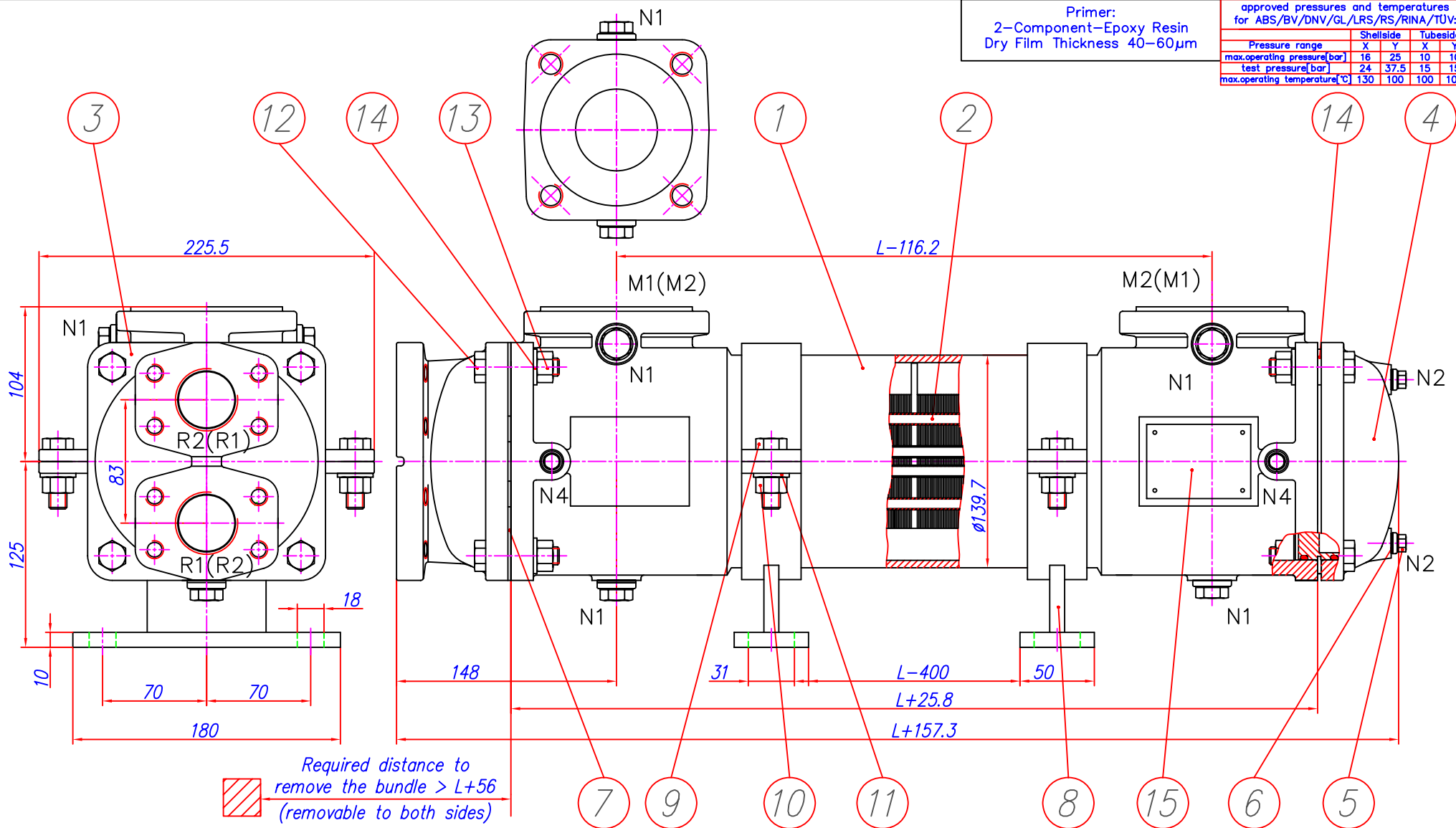

	Shellside	Shellside	Tubeside	Tubeside
Pressure range	X	Y	X	Y
Max. Operating Pressure	-1/16 bar	-1/30 bar	-1/10 bar	-1/10 bar
Test Pressure	20.8 bar	39 bar	13 bar	13 bar
Max. Operating Temperature	-10/130 °C	-10/100 °C	-10/100 °C	-10/100 °C
Content [dm³] (L[m],LT[mm])	$Lx(10-2,74/LT)+0,5$		$2,85xL+1,1$	
Joint-Flange (1=IN/2=OUT)	M1/M2=DN50 (PN40)		R1/R2=1 1/2"SAE(PN16)	
Joint-Thread (1=IN/2=OUT)	-		R1/R2=1 1/4" BSP	
Vent/Drain	N1=1/2"(6x) N4=1/8"(4x)		N2=1/8" (2x)	
Anodes	-		-	

THIS DRAWINGS AND ALL THE DATA CONTAINED HEREIN IS THE EXCLUSIVE PROPERTY OF HS-COOLER GMBH AND MAY NOT BE DISCLOSED TO OTHERS WITHOUT WRITTEN CONSENT.				SURFACE QUALITY DIN ISO 1302		GENERAL TOLERANCE DIN 7168-m		SCALE: 1:2,5		(WEIGHT:)	
				DATE		NAME		(MATERIAL:)			
				DRAW 01.12.99		Garbe					
				CHECK 21.02.00		Graulich		Cooler L800			
D	Bracket material thickness	18.12.09	BS								
C	Corr. long hole-bracket	22.09.09	BS								
B	Test Pressure	01.01.04	Gar								
A	Pressure Y	01.02.02	Gar								
SYM	REV.RECORD	DATE	NAME	KS12-AEP-123				SHEET: 1			
AutoCAD LT 2009								FILE: KS12-A##-#21.dwg			

Pos.	Quantity	Unit	Description	Part/Standard Number	Remark
1	1	pc.	Shell	GS12 - 1	
2	1	pc.	Tube Bundle	RL12 - E P - 1 2 3	
3	1	pc.	Waterbox 1 1/2" SAE	KL12-A-012	AlSi9Mg (3.1) EN-GJL-250 (3.1)
4	1	pc.	Cover	KL12-A-013	AlSi9Mg (3.1) EN-GJL-250 (3.1)
5	2	pc.	Sealing Plug	DIN 910 - G 1/8" A	Steel galv.
6	2	pc.	Sealing Ring	DIN 7603 - A 10 x 13.5 x 1	Aluminium
7	4	pc.	Fixation Plate	KL12-0-108	Steel galv.
8	2	pc.	Clamp Bracket	KL12-0-109	Steel
9	4	pc.	Hex Bolt	ISO 4017 - M12 x 40 - 8.8	Steel galv.
10	4	pc.	Hex Nut	ISO 4032 - M12 - 8	Steel galv.
11	4	pc.	Washer	DIN 125 - A 13	Steel galv.
12	8	pc.	Hex Bolt	ISO 4014 - M12 x 60 - 5.6	Steel galv. AD-W7 (Stamped)
13	8	pc.	Hex Nut	ISO 4032 - M12 - 5-2	Steel galv. AD-W7 (Stamped)
14	12	pc.	Washer	DIN 125 - A 13	Steel galv.
15	1	pc.	Type Plate		Aluminium

SYM	REVISION	DATE	NAME



DATE	NAME
DRAW 29.11.99	Garbe
CHECK 29.11.99	Graulich
NORM	
Parts List	
KS12 - AEP - 123	
FILE: Parts List KS12.doc	
Sheet 1 of 1	

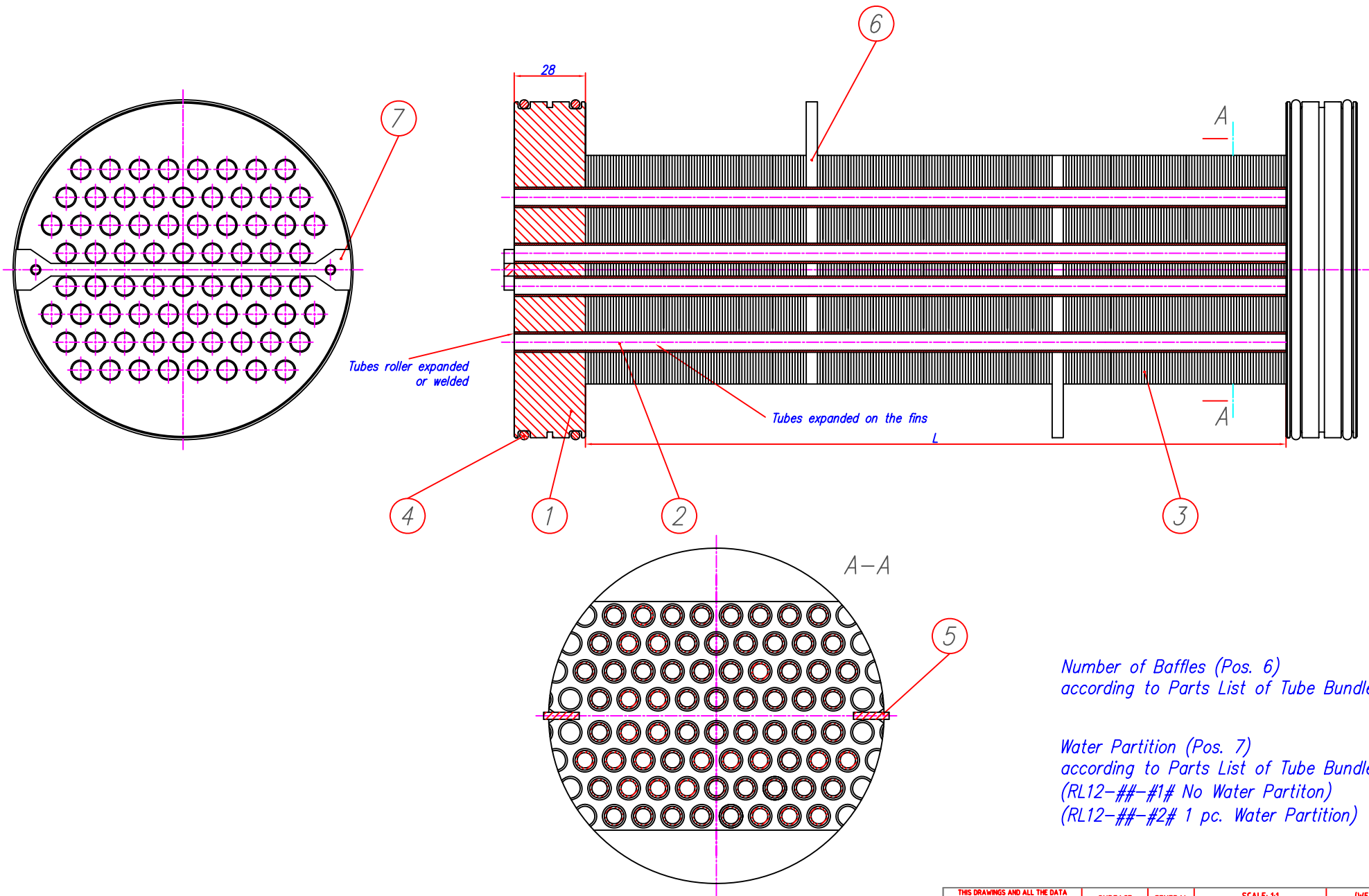

Number of Baffles (Pos. 6)
according to Parts List of Tube Bundle

Water Partition (Pos. 7)
according to Parts List of Tube Bundle
(RL12-##-#1# No Water Partiton)
(RL12-##-#2# 1 pc. Water Partition)

THIS DRAWINGS AND ALL THE DATA CONTAINED HEREIN IS THE EXCLUSIVE PROPERTY OF HS-COOLER GMBH AND MAY NOT BE DISCLOSED TO OTHERS WITHOUT WRITTEN CONSENT.				SURFACE QUALITY DIN ISO 1302		GENERAL TOLERANCE DIN 7168-m		SCALE: 1:1		(WEIGHT)	
				DATE		NAME		(MATERIAL)		Format: A2	
				DRAW 24.09.04		Garbe		Tube Bundle			
				CHECK 24.09.04		Graulich					
				HS-Cooler				RL12-##-###		SHEET: 1	
A velle RP - neuer TS 20.10.04 Gar				SYM REV.RECORD DATE NAME				AutoCAD LT2006		FILE: RL12-E(T)1#-###.dwg	

