

Item Qty	Description	Standard	Material	Note
1	PL 5 x 325 x 4,45	SI 37,2		
2	Mutter M10	DIN 934		
3	PL 3 x $\phi$ 15	SI 37,2		Forsikres
4	PL 60 x 280 x 4,00	POM		

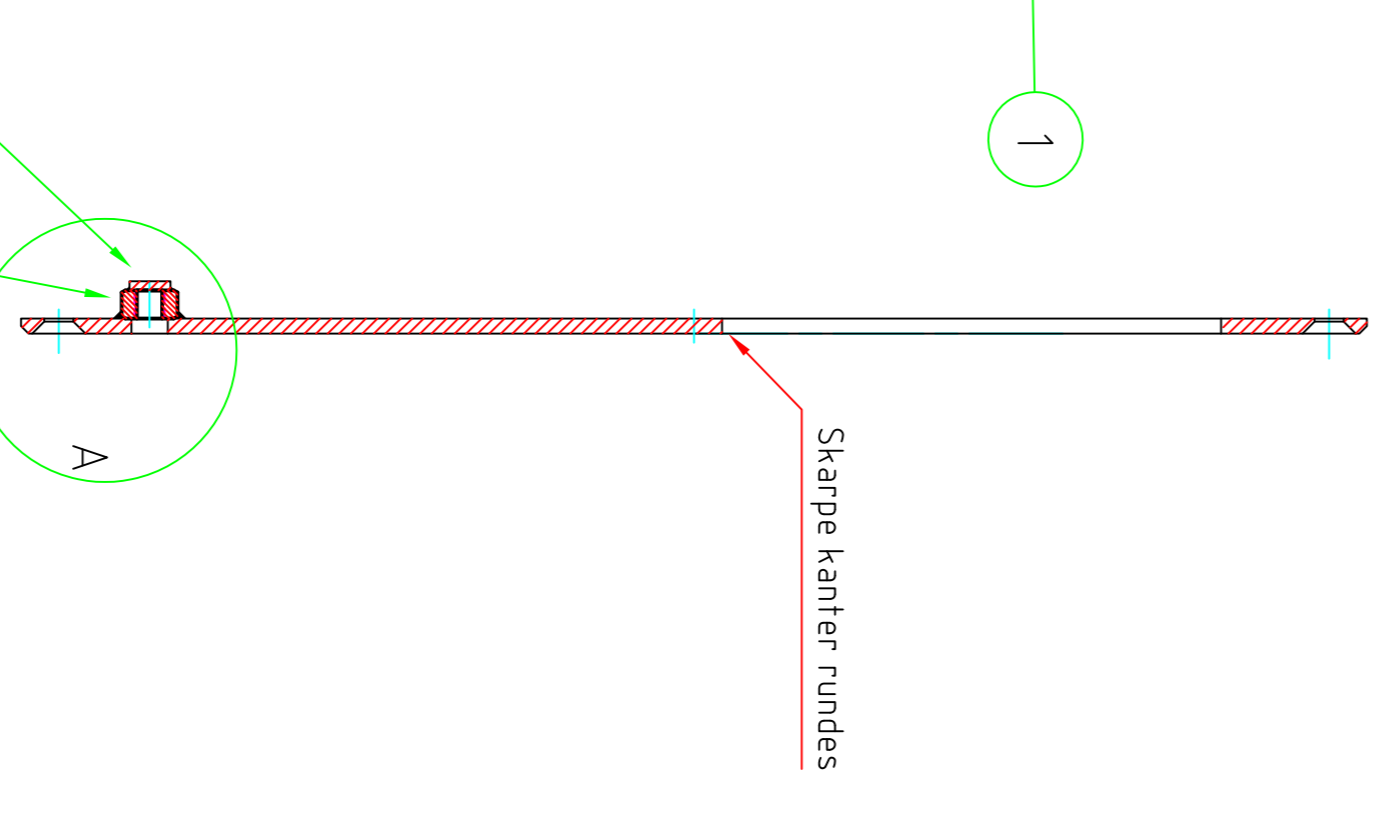

A (1:1,25)

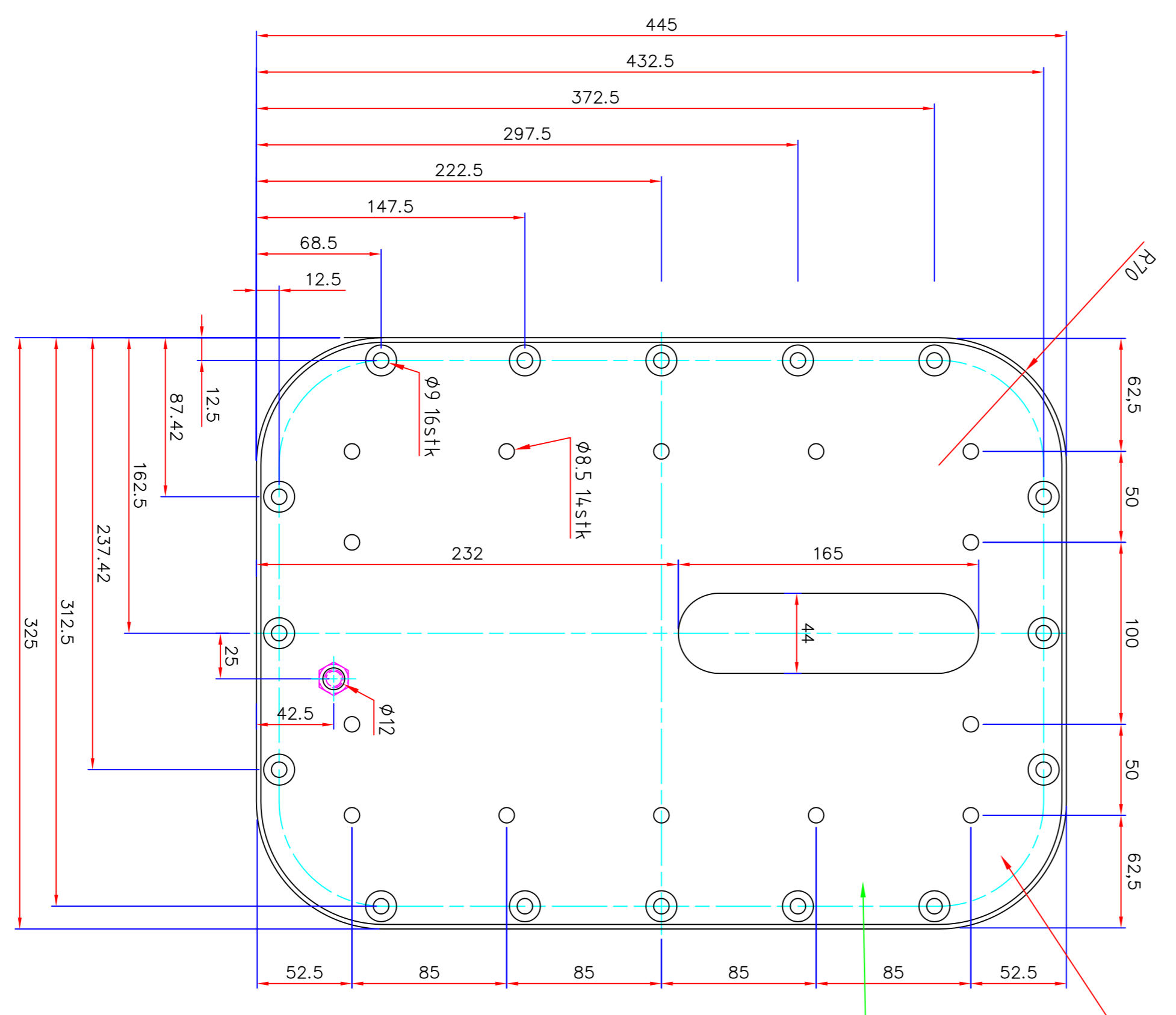
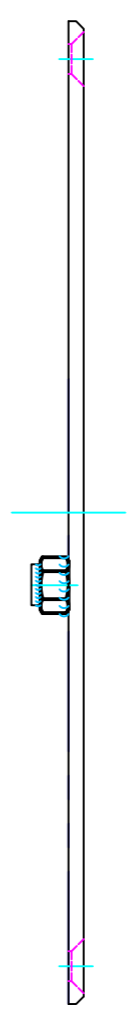
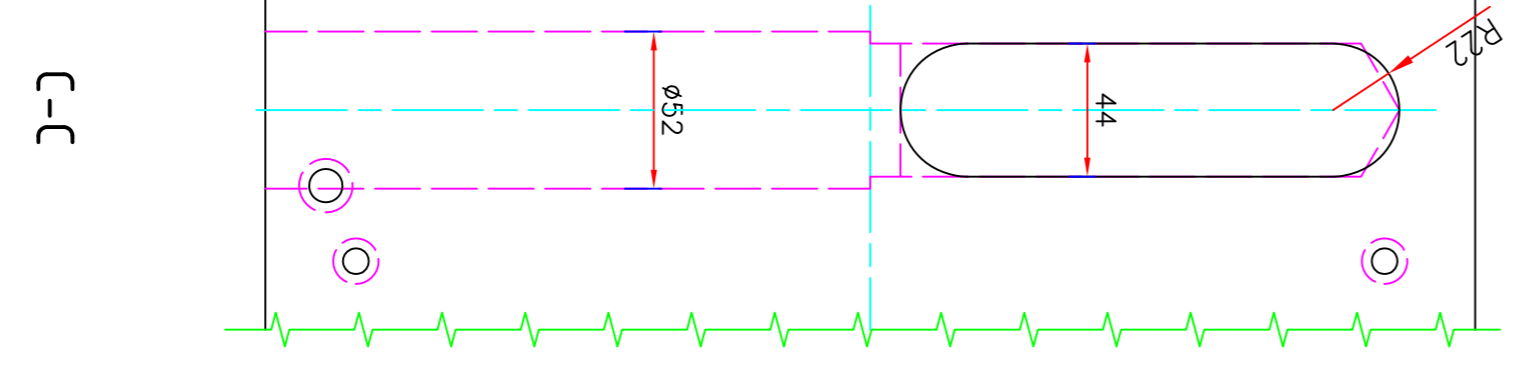
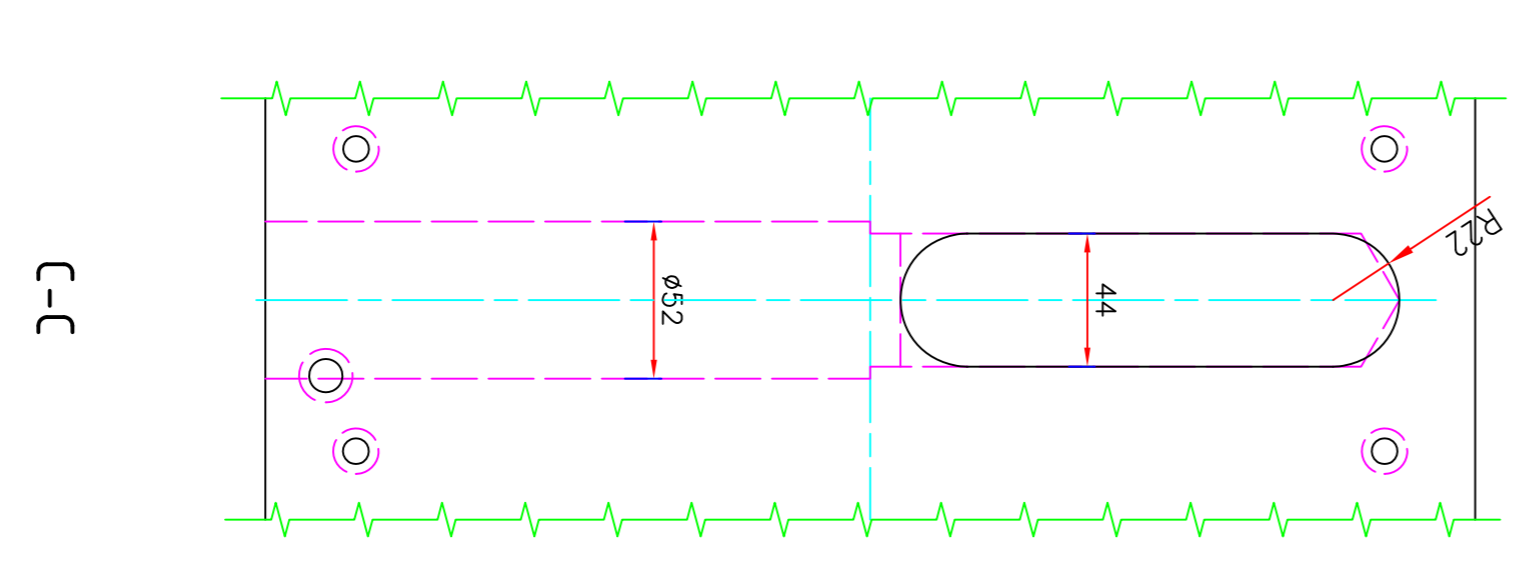
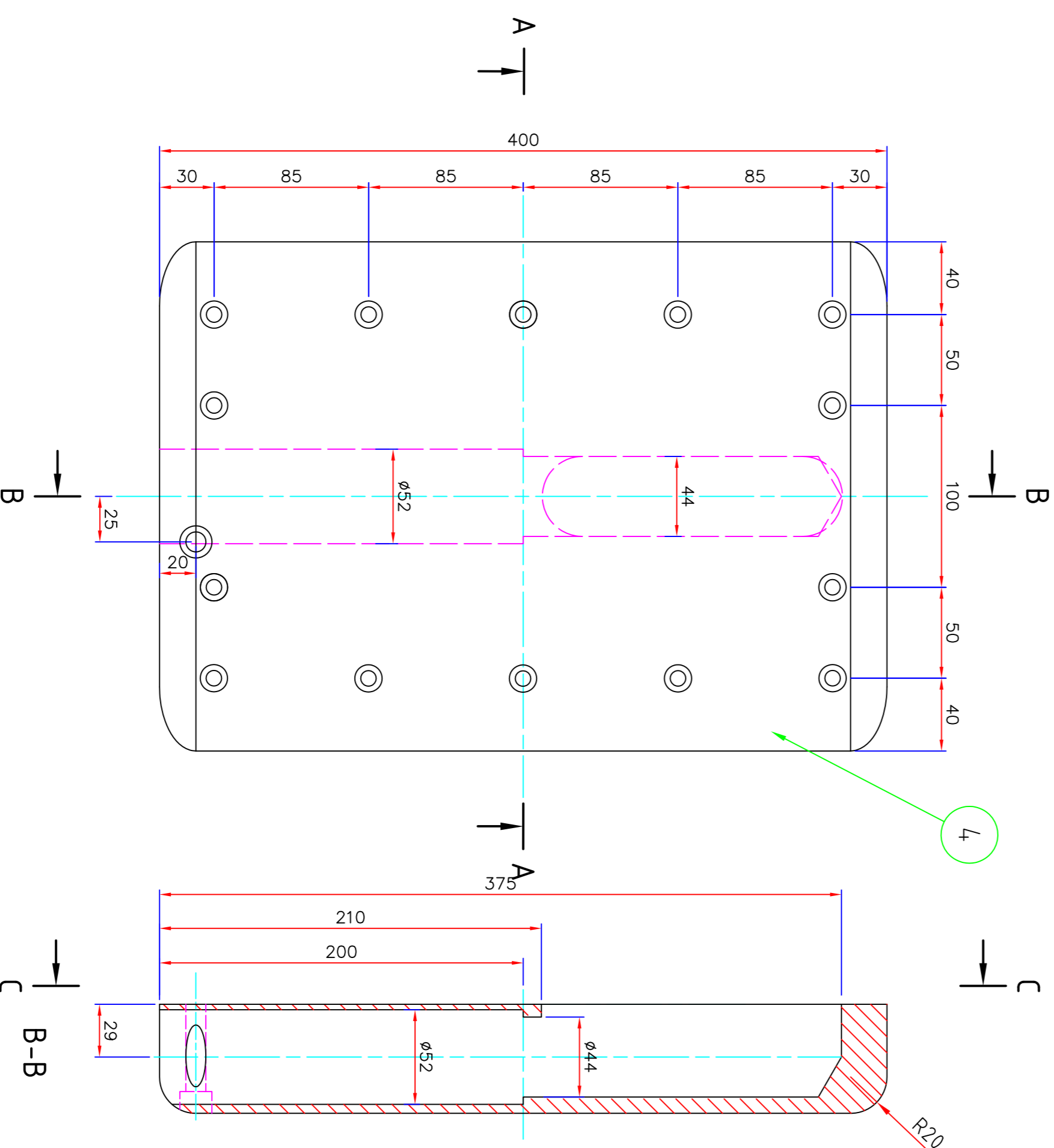
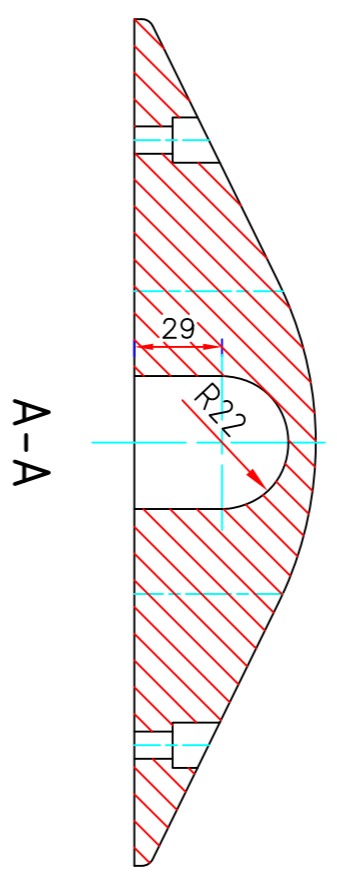
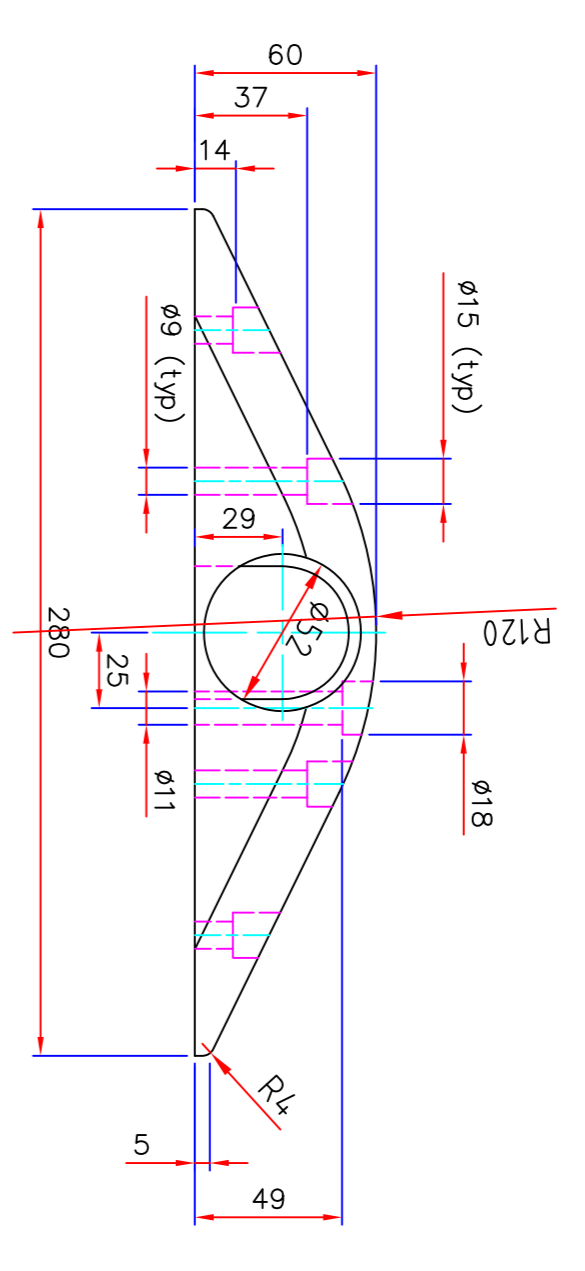

**Forservets Forsikringsvesenstiftelse**  
 Forsikringsvesenstiftelse

Prosjekt: **HU Sverdrup**  
 Smart probe - Fundam. bus

Skala: 1:2,5

Dato: 08.09.2010 R&B

Rev: **A**