

TEGNINGSLISTE

TEGN.NR.	TEGNING-TEKST	MÅLST.	DATO
L 103P-00-00-301	OVERSIKTSPLAN LANDSKAP	1:500	08.06.23
L 112P-NB-00-301	LANDSKAPSPLAN, DELOMRÅDE 1	1:200	08.06.23
L 112P-BT-00-301	LANDSKAPSPLAN, DELOMRÅDE 2	1:200	08.06.23
L 112P-TZ-00-301	LANDSKAPSPLAN, DELOMRÅDE 3	1:200	08.06.23
L 112P-AK-00-301	LANDSKAPSPLAN, DELOMRÅDE 4	1:200	08.06.23
L 600P-00-00-301	KANTPLAN	1:400	08.06.23



TEGNFORKLARING

- Eksisterende tre
- Nytt tre
- Gress
- Busk
- Belegningstein
- Asfalt
- Betong
- Mur
- Gjerde
- Kantstein, granitt
- Benk
- Sykkelparkering
- Eks. lysmast
- Eks. innfelt lys i mur
- Ny lysmast, 2 armaturer
- Ny parkmast, 6 m
- Parkeringsautomat
- Fallpil
- Eksisterende sluk
- Nytt sluk
- Delområder
- Eks. element fjernes

A01	08.06.23	TILBUDSTEGNING	JSH	JCD	HH
REV	DATE	BESKRIVELSE	TEGN KONT GODK		

FASE: Tilbudstegning					
FAG	TYPE	FLØY	ETG	LNR	FAS. REV.
L	103P	00	00	301	A 01

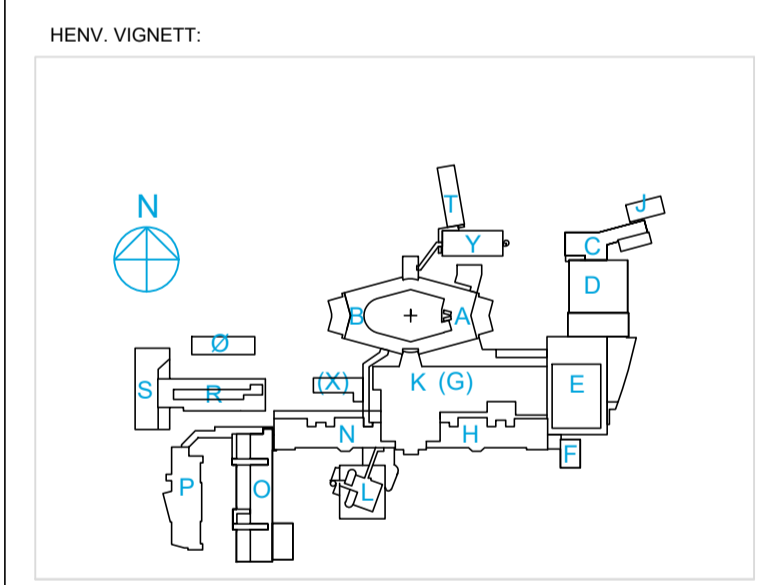

NORDLANDSSYKEHUSET BODØ
SOMATIKK

PROSJEKTERENDE:
 RATIO ARKITEKTER AS, DRAMMENSVEIEN 130 B, 0277 OSLO
 RIV COWI AS/ OTTO NIELSENS VEI 12, 7414 TRONDHEIM
 RIB RATIO ARKITEKTER AS v/ BJØRBEKK & LINDHEIM AS.
 LARK

RATIO ARKITEKTER AS
 En fusjon av BGO arkitekter as og Medplan as arkitekter







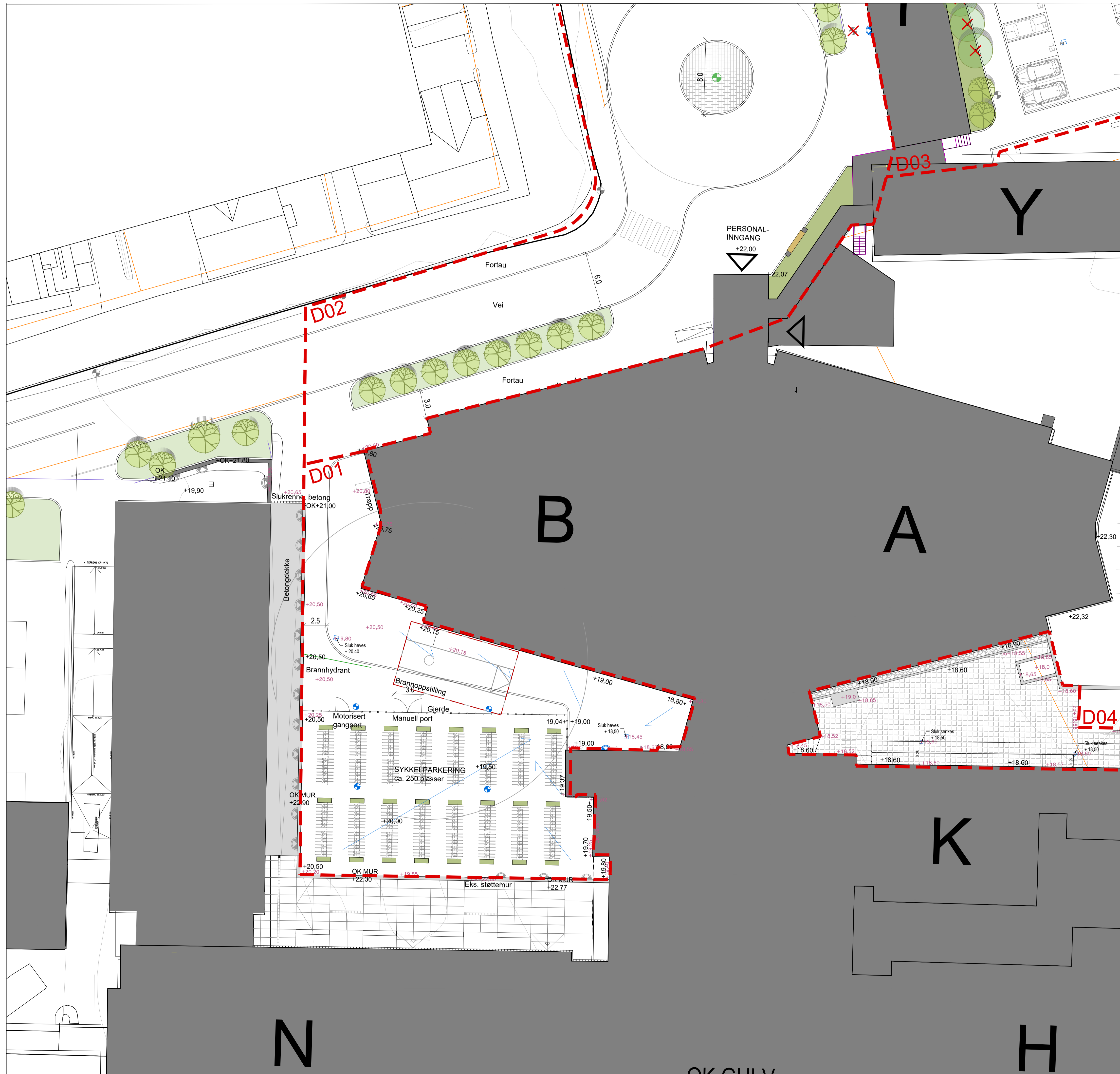

PROSJEKT NR.: 23023 TL.STAT.:

Oversiktsplan landskap
 Delområder
 Fase 3 (etterarbeider)

MÅL:	1:500 (A1)	DATE:	19.04.2023		
FAG	TYPE	FLØY	ETG	LNR	FAS. REV.
L	103P	00	00	301	A 01

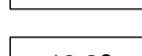

TEGNFORKLARING

-  Drensstein
-  Elvegrus
-  Betong
-  Asfalt
-  Sykkelparkering, flyttbar
-  Eks. lysmast
-  Eks. innfelt lys i mur
-  Fallpil
-  Eks. kuppelrist
-  Eks. sluk
-  Gjerde
-  +19.80 Nye punkthøyder
-  +18.55 Eks. punkthøyder fra scan
-  Plantekasse, flyttbar
-  Ny lysmast, 2 armaturer
-  Ny parkmast, 6 m
-  Eks. element fjernes
-  Delområde

REV	DATO	BESKRIVELSE	JSH	JCD	HH
A01	08.06.23	TILBUDSTEGNING			
					TEGN KONT GODK

FASE: Tilbudstegning					
FAG	TYPE	FLØY	ETG	LNR	FAS. REV.
L	112P	NB	00	301	A 01

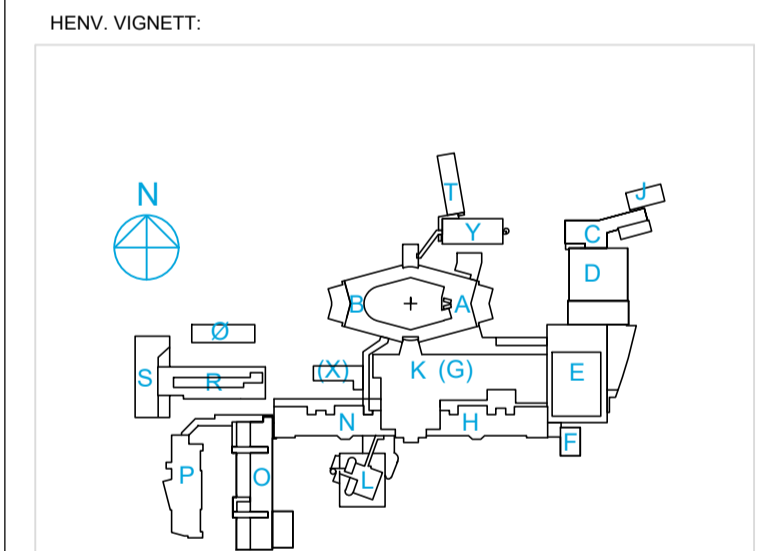

PROSJEKTERENDE:
 RATIO ARKITEKTER AS, DRAMMENSVEIEN 130 B, 0277 OSLO
 RIV
 RIE COWI AS/ OTTO NIELSENS VEI 12, 7414 TRONDHEIM
 RIB
 LARK RATIO ARKITEKTER AS v/ BJØRBEKK & LINDHEIM AS.

RATIO ARKITEKTER AS
 En fusjon av BGO arkitekter as og Medplan as arkitekter

PROSJEKT NR.: 23023 TL.STAT.:

INNHOLD:
 Landskapsplan
 Delområde 1
 Fase 3 (etterarbeider)

MÅL:	1:200 (A1)	DATO:	19.04.2023		
FAG	TYPE	FLØY	ETG	LNR	FAS. REV.
L	112P	NB	00	301	A 01

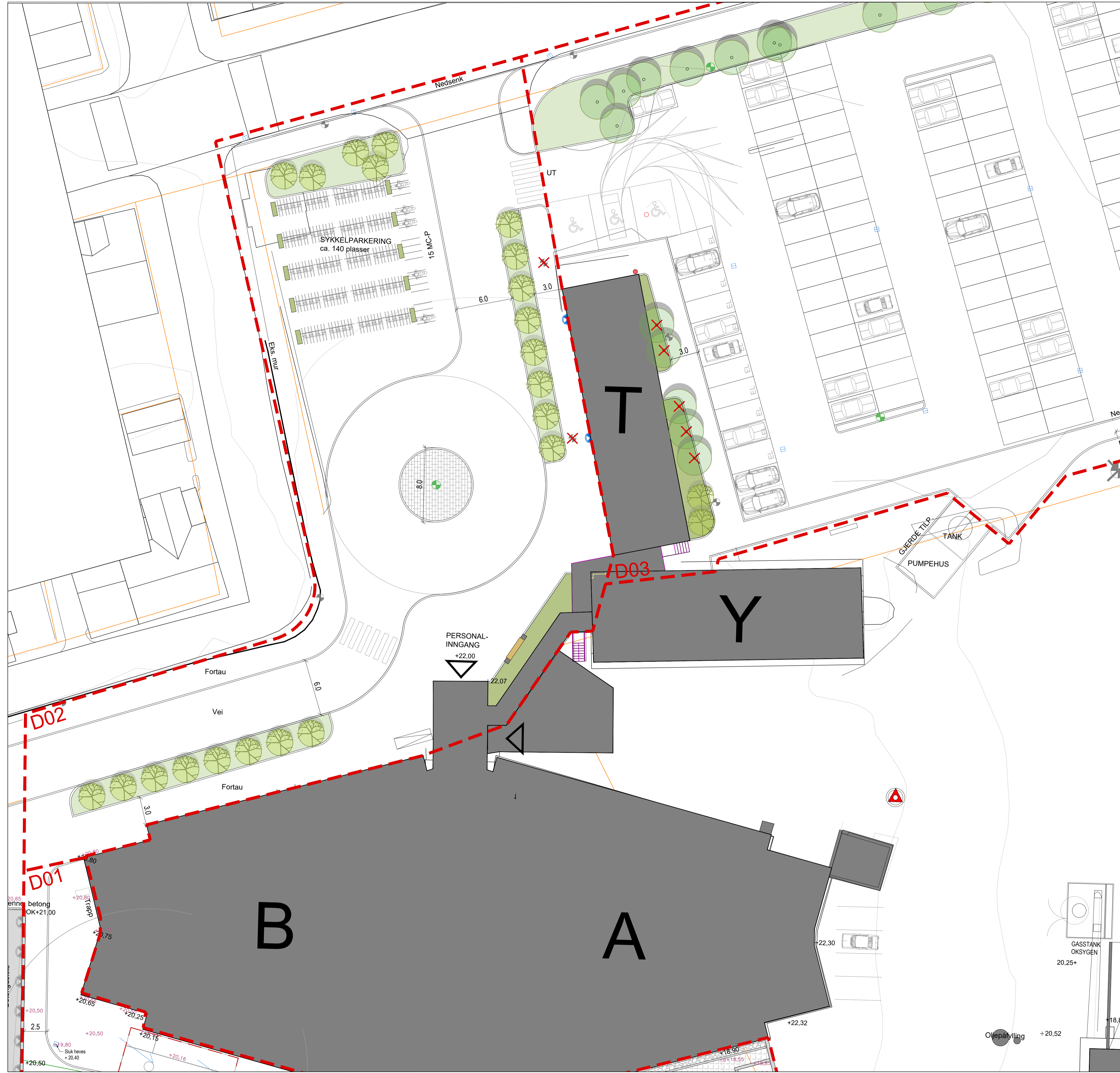

TEGNFORKLARING

- Eksisterende tre
- Nytt tre
- Gress
- Busker
- Belegningsstein
- Asfalt
- Betong
- Mur
- Gjerde
- Kantstein, granitt
- Benk
- Sykkelparkering, flyttbar
- Eks. lysmast
- Eks. innfelt lys i mur
- Billettautomat
- Fallpil
- Eks. sluk
- Nytt sluk
- Nye punkthøyder
- Eks. punkthøyder fra scan
- Plantekasse, flyttbar
- Ny lysmast, 2 armaturer
- Ny parkmast, 6 m
- Eks. element fjernes
- Delområde

A01	08.06.23	TILBUDSTEGNING	JSH	JCD	HH
REV	DATE	BESKRIVELSE	TEGN	KONT	GDOK

FASE: Tilbudstegning					
FAG	TYPE	FLØY	ETG	LNR	FAS. REV.
L 112P BT 00 301 A 01					

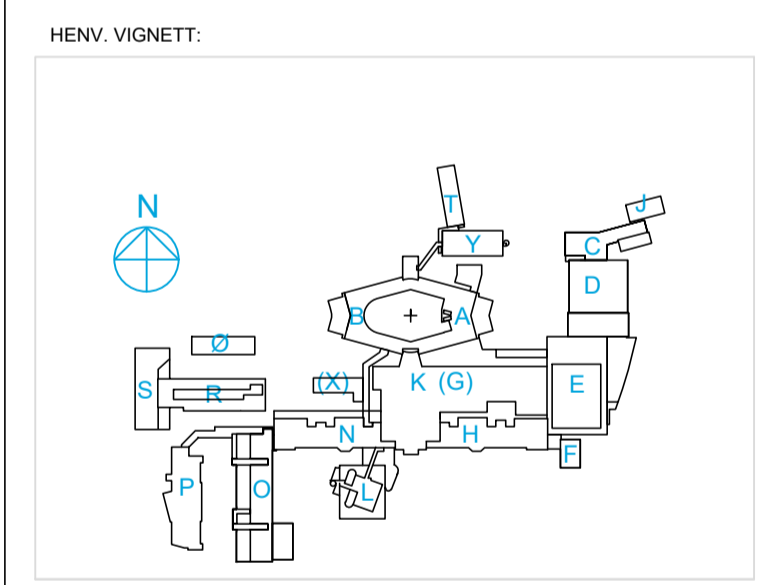

NORDLANDSSYKEHUSET BODØ
SOMATIKK



PROSJEKTERENDE:
 ARK RATIO ARKITEKTER AS, DRAMMENSVEIEN 130 B, 0277 OSLO
 RIV COWI AS/ OTTO NIELSENS VEI 12, 7414 TRONDHEIM
 RIE
 RIB
 LARK RATIO ARKITEKTER AS v/ BJØRBEKK & LINDHEIM AS.

RATIO ARKITEKTER AS
 En fusjon av BGO arkitekter as og Medplan as arkitekter

PROSJEKT NR.: 23023 TL.STAT.:

INNHOLD:
 Landskapsplan
 Delområde 2
 Fase 3 (etterarbeider)

MÅL:	1:200 (A1)	DATE:	19.04.2023		
FAG	TYPE	FLØY	ETG	LNR	FAS. REV.
L 112P BT 00 301 A 01					



TEGNFORKLARING

- Eksisterende tre
- Nytt tre
- Gress
- Busker
- Asfalt
- Betong
- Kantstein, granitt
- Eks. lysmast
- Billettautomat
- Fallpil
- Eks. sluk
- Nytt sluk
- +19,80 Nye punkthøyer
- +18,55 Eks. punkthøyer fra scan
- Ny lysmast, 2 armaturer
- Ny parkmast, 6 m
- Eks. element fjernes
- Delområde

REV	DATE	BESKRIVELSE	JSH	JCD	HH
A01	08.06.23	TILBUDSTEGNING			
					TEGN KONT GODK

FASE: Tilbudstegning					
FAG	TYPE	FLØY	ETG	LNR	FAS. REV.
L 112P	TZ	00	301	A	01

HENV. VIGNETT:

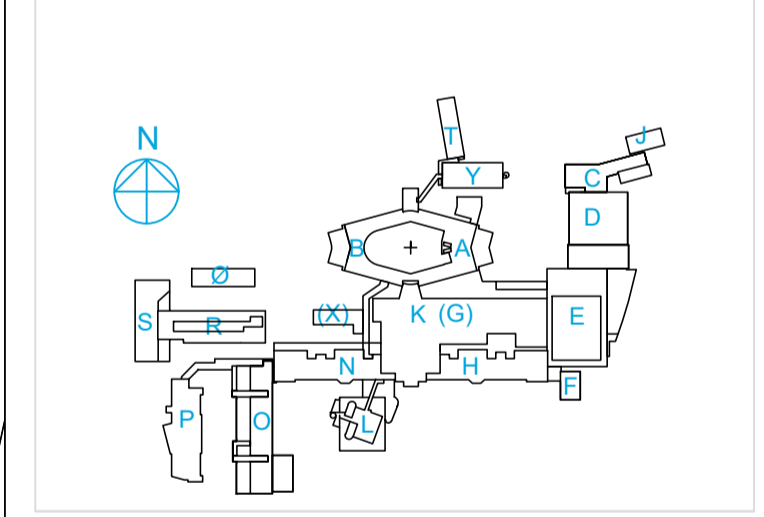

NORDLANDSSYKEHUSET BODØ
SOMATIKK



PROSJEKTERENDE:
 ARK: RATIO ARKITEKTER AS, DRAMMENSVEIEN 130 B, 0277 OSLO
 RIV: COWI AS/ OTTO NIELSENS VEI 12, 7414 TRONDHEIM
 RIE: RIB: RATIO ARKITEKTER AS v/ BJØRBEKK & LINDHEIM AS, LARK:

RATIO ARKITEKTER AS
 En fusjon av BGO arkitekter as og Medplan as arkitekter



PROSJEKT NR.: 23023
 INNHOOLD: TL.STAT:

Landskapsplan
 Delområde 3
 Fase 3 (etterarbeider)

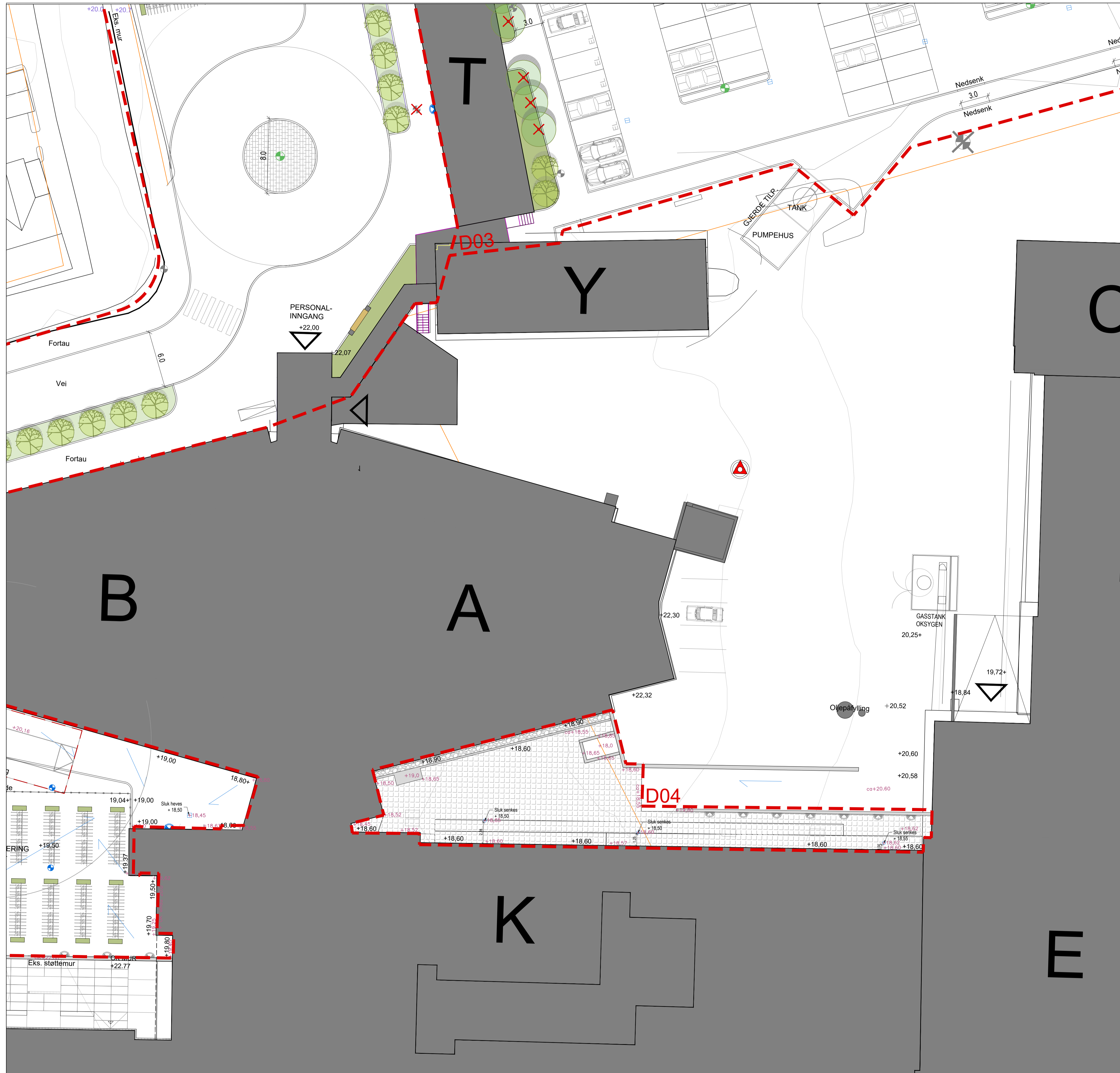
MÅL:	1:200 (A1)	DATE:	19.04.2023
FAG	TYPE	FLØY	ETG
L 112P	TZ	00	301
			A 01

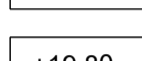

TEGNFORKLARING

-  Drensstein
-  Elvegrus
-  Betong
-  Asfalt
-  Sykkelparkering, flyttbar
-  Eks. lysmast
-  Eks. innfelt lys i mur
-  Fallpil
-  Eks. kuppelrist
-  Eks. sluk
-  Gjerde
-  +19.80 Nye punkthøyder
-  +18.55 Eks. punkthøyder fra scan
-  Plantekasse, flyttbar
-  Ny lysmast, 2 armaturer
-  Ny parkmast, 6 m
-  Eks. element fjernes
-  Delområde

A01	08.06.23	TILBUDSTEGNING	JSH	JCD	HH
REV	DATO	BESKRIVELSE	TEGN	KONT	GOOK

FASE: Tilbudstegning					
FAG	TYPE	FLØY	ETG	LNR	FAS. REV.
L 112P	AK	00	301	A	01

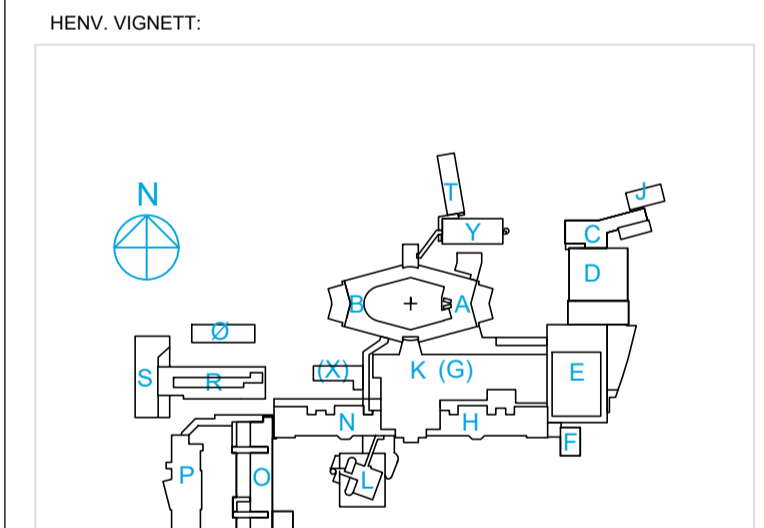

NORDLANDSSYKEHUSET BODØ
SOMATIKK



PROSJEKTERENDE:
 ARK: RATIO ARKITEKTER AS, DRAMMENSVEIEN 130 B, 0277 OSLO
 RIV: COWI AS/ OTTO NIELSENS VEI 12, 7414 TRONDHEIM
 RIB: RATIO ARKITEKTER AS v/ BJØRBEKK & LINDHEIM AS.
 LARK:

RATIO ARKITEKTER AS
 En fusjon av BGO arkitekter as og Medplan as arkitekter

PROSJEKT NR.: 23023 TL.STAT.:
 INNHOLD:

Landskapsplan
 Delområde 4
 Fase 3 (etterarbeider)

MÅL:	1:200 (A1)	DATO:	19.04.2023		
FAG	TYPE	FLØY	ETG	LNR	FAS. REV.
L 112P	AK	00	301	A	01

Sist logret: 05.06.2023 av JSH. Filbane: P:\1150 - 1199\1172 - Nordlandssykehuset\3_tegning\arbeid\13 - Arbeid 2023\1_DAK\1_AM Arbeidsmodell\AM_1172_Landskapsplan_NSJK_mengdeplan.dwg

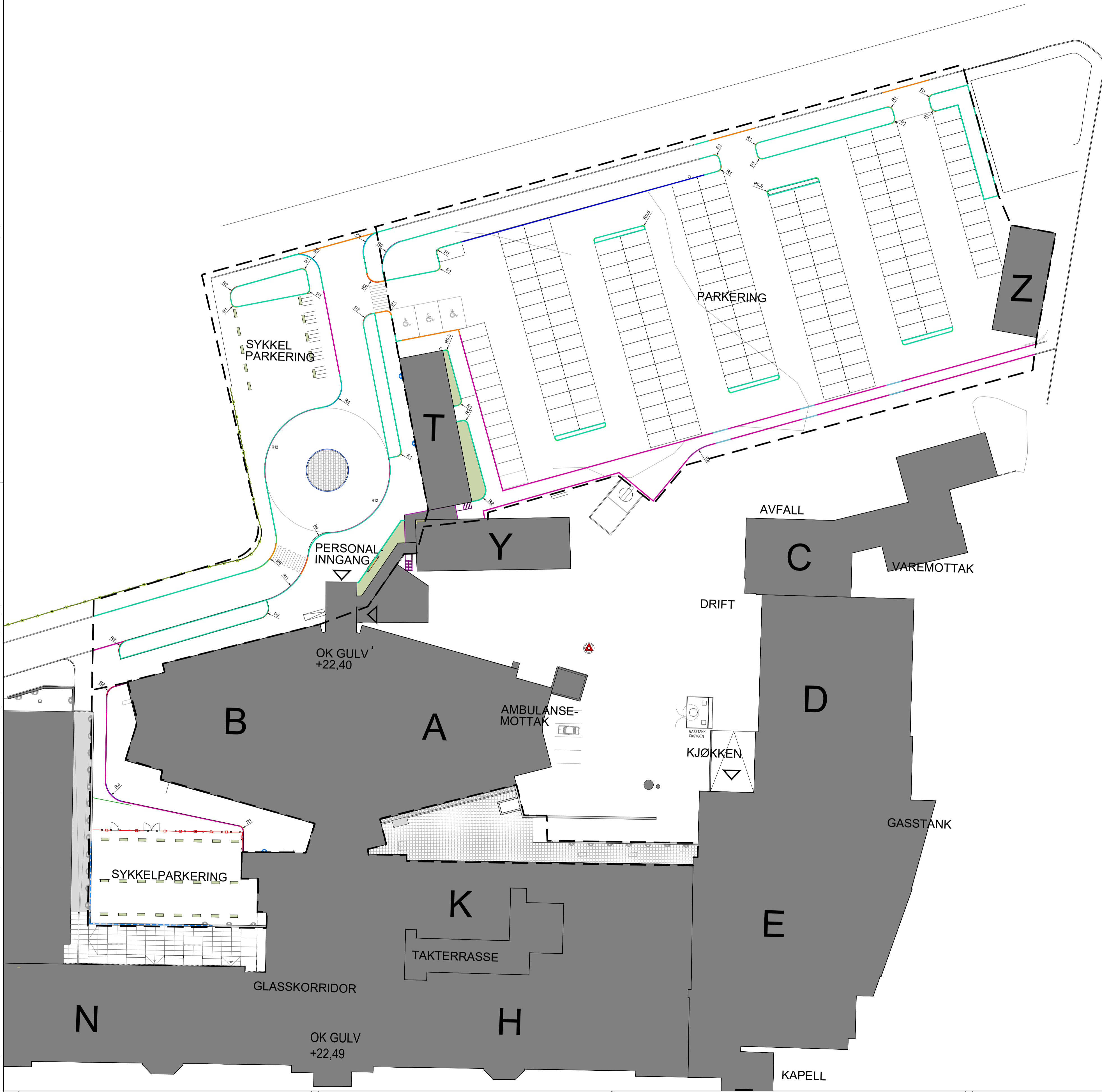

TEGNFORKLARING

Delområde 1

- Kanstein, granitt 40 mm vis 55 m
- Gjerde, sykkelparkering 30 m
- Glassrekkverk, komplementering eks. 40 m
- Kantstein R1 2 m
- Kantstein R2 3 m
- Kantstein R4 6 m

Delområde 2

- Kantstein, granitt 100 mm vis 320 m
- Kanstein, granitt 40 mm vis 25 m
- Kanstein, granitt 20 mm vis 30 m
- Gjerde, støttemur 100 m
- Kantstein R1 8 m
- Kantstein R2 16 m
- Kantstein R4 49 m
- Kantstein R11 13 m
- Kantstein R12 39 m

Delområde 3

- Kantstein, granitt 100 mm vis 320 m
- Kanstein, granitt 40 mm vis 235 m
- Kanstein, granitt 20 mm vis 30 m
- Kanstein, granitt 0 mm vis 18 m
- Kantstein R0,5 9 m
- Kantstein R1 19 m
- Kantstein R2 4 m
- Kantstein R5 8 m
- Kantstein R8 5 m

NB!
Prinsipiell oversikt over ulike alternativer.

REV	DATE	BESKRIVELSE	JSH	JCD	HH
A01	08.06.23	TILBUDSTEGNING			

FASE: Tilbudstegning					
FAG	TYPE	FLØY	ETG	LNR	FAS. REV.
L	600	00	00	301	A 01

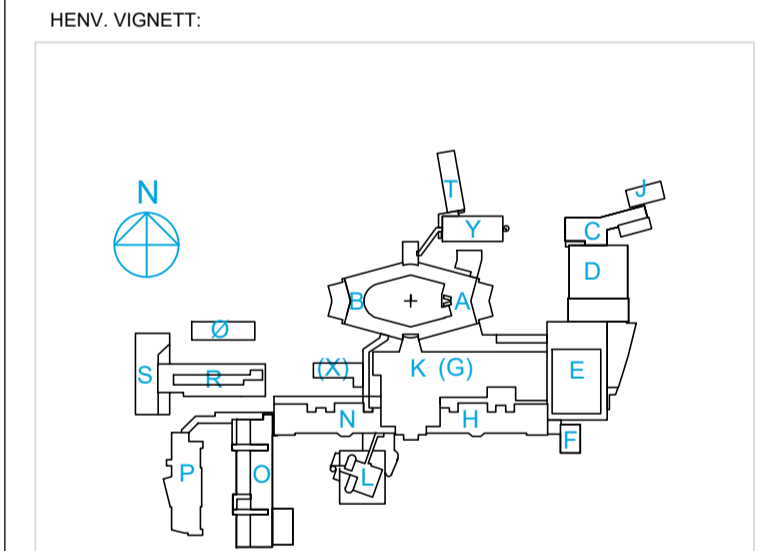

NORDLANDSSYKEHUSET BODØ
SOMATIKK

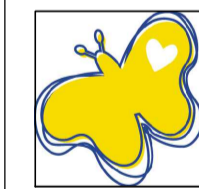

PROSJEKTERENDE:	
ARK	RATIO ARKITEKTER AS, DRAMMENSVEIEN 130 B, 0277 OSLO
RIV	
RIE	COWI AS/ OTTO NIELSENS VEI 12, 7414 TRONDHEIM
RIB	
LARK	RATIO ARKITEKTER AS v/ BJØRBEKK & LINDHEIM AS.

RATIO ARKITEKTER AS
En fusjon av BGO arkitekter as og Medplan as arkitekter

PROSJEKT NR.:	TL STAT.:
23023	

Kantplan
Fase 3 (etterarbeider)

MÅL:	1:400 (A1)	DATE:	19.04.2023			
FAG	TYPE	FLØY	ETG	LNR	FAS.	REV.
L	600P	00	00	301	A	01