

# Utsparingsmål sjakt

Unit in Shaft

Utsparingsmål dørfronter		
Etasje	Bredde	Høyde
A 1	1553	2250
C 2	1553	2250

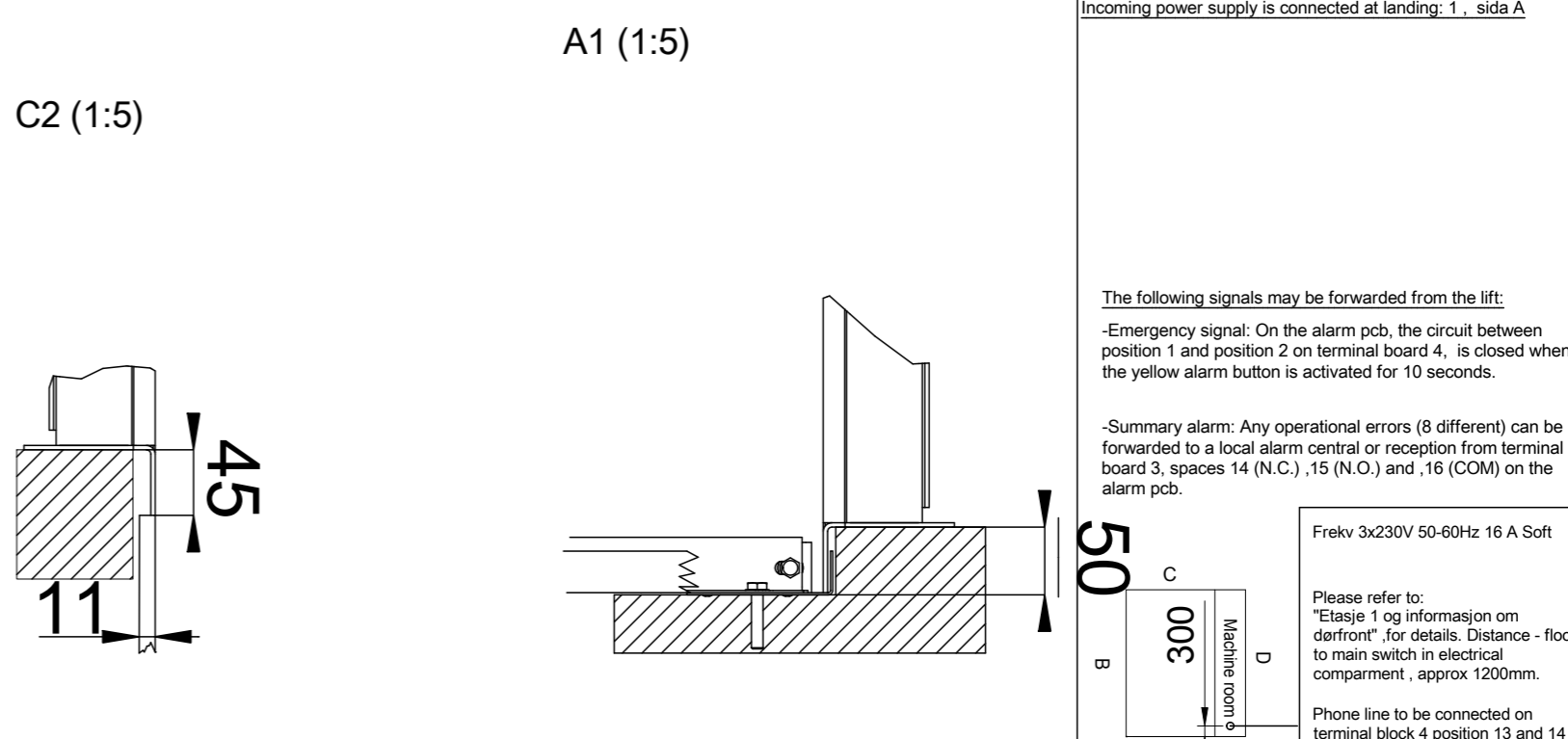
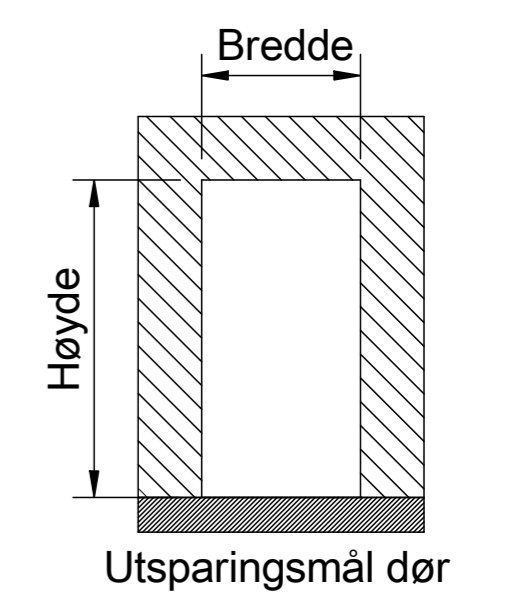
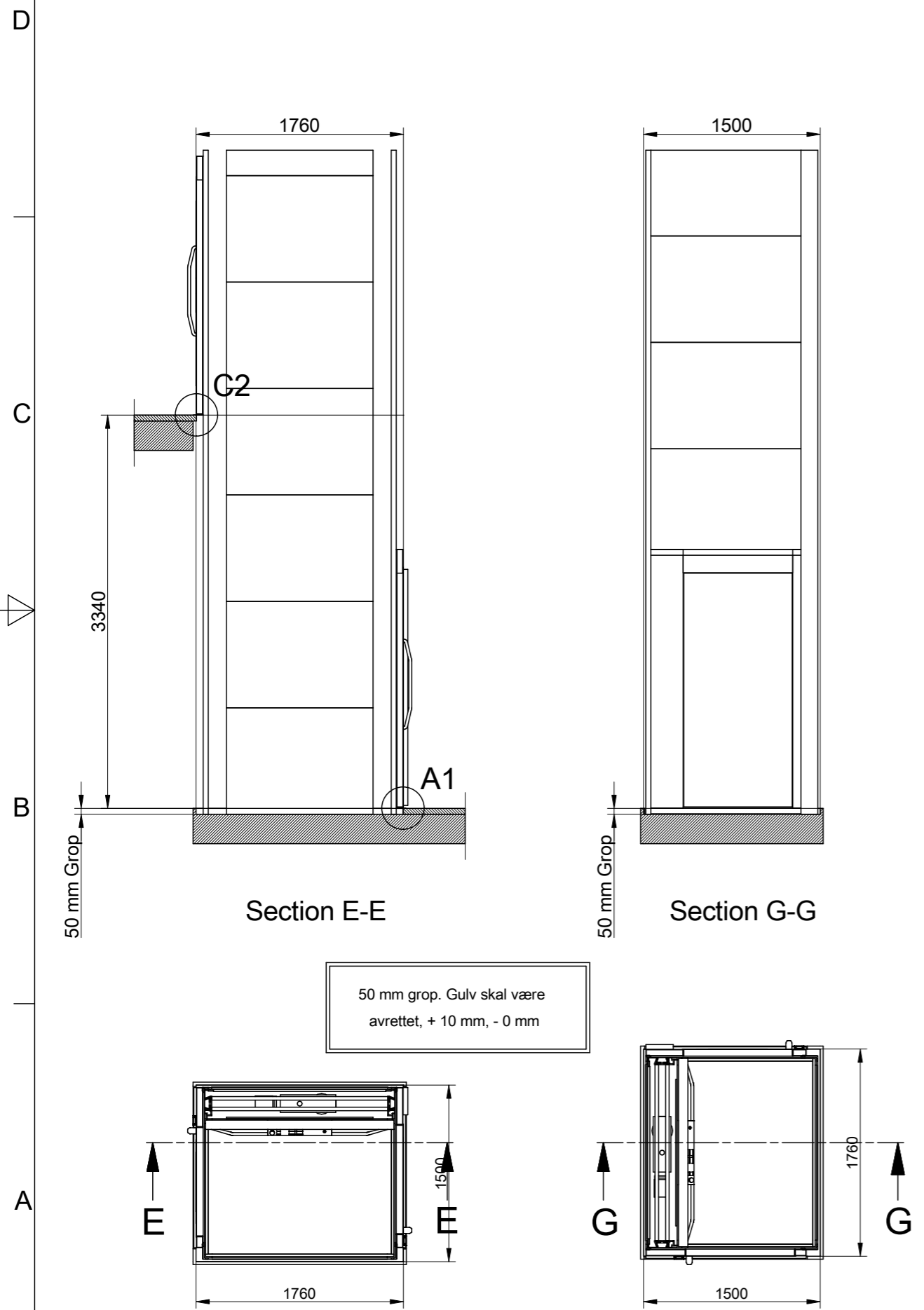

Godkjent av kunde: _____	Tilbud	<b>Prinsipptegning</b> A400 - 1100*1597 Cut out sizes		
	Ordre			
European view placement:	Gen. Tolerances SS-ISO 27681-1 m	Dato 2017-03-07	Side 2 of 6	Scale: A3, 1:45

# OTIS