

DETAIL A  
SCALE 1 : 10  
14 mm ingress into platform

Max Static Weight / Actuator = 250 kg

Drawing  
34074

<b>Distributor :</b>		Joar Gran	
Customer Ref :			
Customer Name :		Joar Gran	
<b>Model :</b>	<b>FlexStep 5 Steps</b>	A4	
Lifting Capacity : 400 kg	All Rights Reserved Liftup A/S All dimensions in mm		



Liftup Order Number:

Scale: 1:40 16-11-2021

- (A) Distance between aluminium profiles
- (B) CC wall profile fixation
- (C) Minimum Dimension, Local Building Regulation may apply

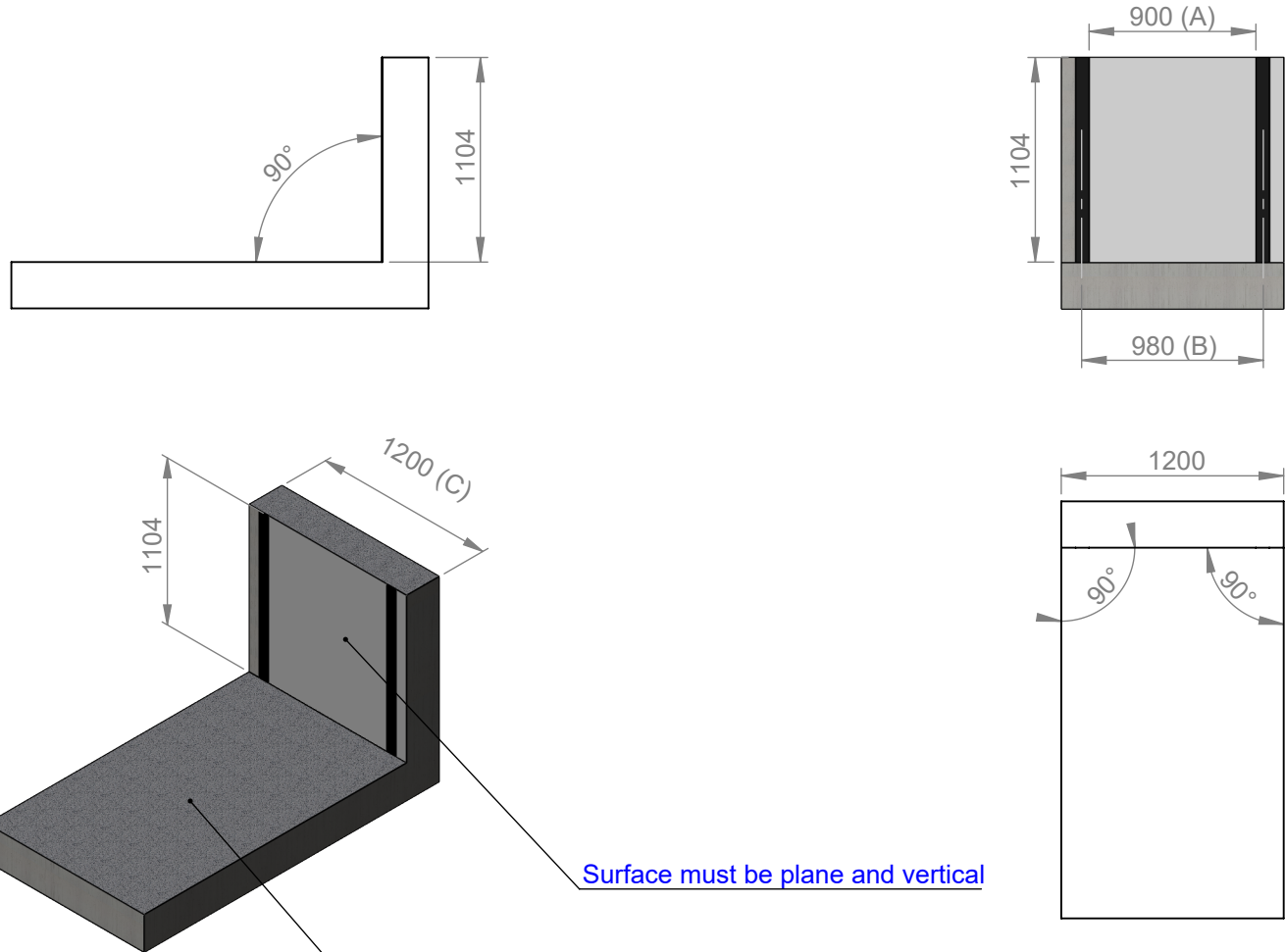

Surface must be plane and horizontal :  
+/- 5 mm per 1000 mm

**BUILDING SPECIFICATIONS**

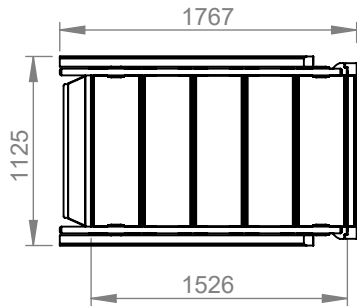
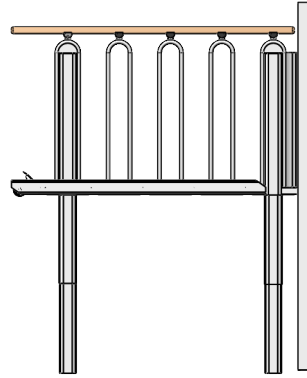
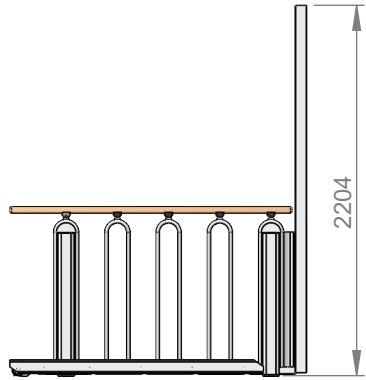

**Drawing  
34074**

<b>Distributor :</b>			
Customer Ref : Customer Name :			
Model : <b>FlexStep 5 Steps</b>		A4	Liftup Order Number:
Lifting Capacity : 400 kg	All Rights Reserved Liftup A/S All dimensions in mm		Scale: 1:40 16-11-2021



**PRODUCT DIMENSIONS**

**Drawing  
34074**

<b>Distributor :</b>		 Liftup Order Number:	
Customer Ref :			
Customer Name :		Joar Gran	
<b>Model :</b>	<b>FlexStep 5 Steps</b>	A4	
Lifting Capacity : 400 kg	All Rights Reserved Liftup A/S All dimensions in mm		Scale: 1:40 16-11-2021

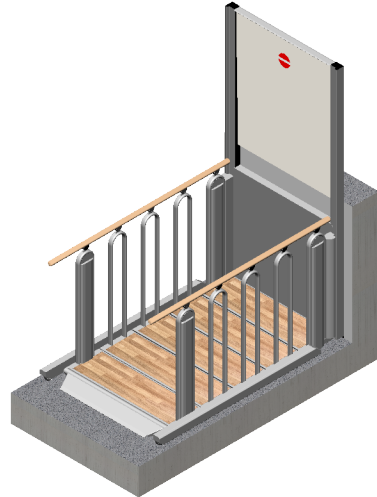



**Important : Specifications in the table below are NOT production informations. Please refer to LIFTUP official order Confirmation !**

Specifications / Options	Your Product
Environment	Indoor
Platform Width (mm)	900
Travel Height (mm)	1104
Operating Panel Position	Left Hand Side
Step Inserts	Oak
Handrails	Oak
Wood Treatment	
Balustrade Type	Round
Lift Colour	Grey Akzo 900 Sablé
RAL	
Top Level Safety	Vertical Barrier
Alarm functionality	
Lower Landing Call Station	
Mount Call Station on Column	No
Upper Call St.	
Mount Call Station on Column	No
Remote Handheld	0
Wireless Receiver Added	No
Key Switch ON/OFF (2 keys included)	No
Extra Keys	0
Prepared for Disassembly	No
Weight of the product	210 kg / 463 lbs
Landing Instructions	No
Packing	
User Manual Language	UK

**PRODUCT SPECIFICATIONS**

**Drawing  
34074**

<b>Distributor :</b>		 Liftup Order Number:	
Customer Ref :			
Customer Name :		Joar Gran	
Model :	<b>FlexStep 5 Steps</b>	A4	
Lifting Capacity : 400 kg	All Rights Reserved Liftup A/S All dimensions in mm		Scale: 1:40 16-11-2021