

technical specification
Vinmonopolet
model. men's trousers
art no. 5400404



VINMONOPOLET

2021-09-01

Article description

Men's trousers in colour dark grey melange with shell fabric inside waistband.

Fabric: 53% polyester, 43% wool, 4% elastane

Pocket lining: Light TC 65% cotton, 35% polyester in black colour

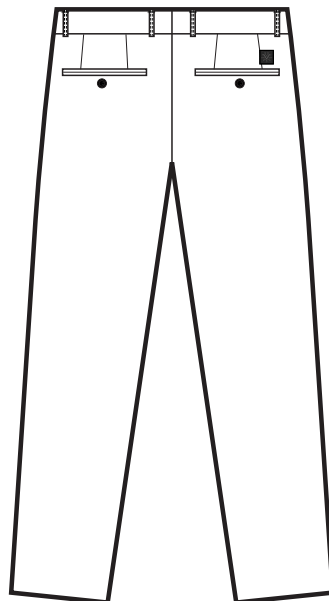
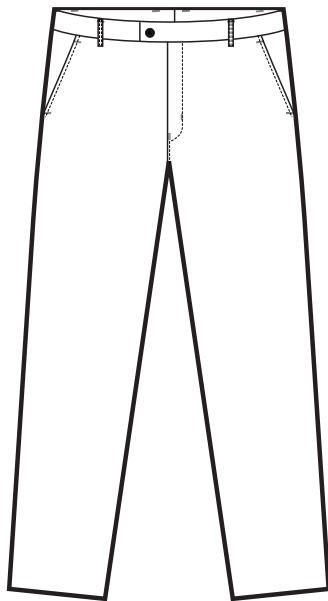



Material specification:

Supplier/Art No:	
Composition:	53% polyester, 43% wool, 4% elastane
Construction:	54/2x54/2, solid dyed
Fabric weight:	205 g/m ²
Inside waistband:	In shell fabric
Colour:	Dark Grey Melange
Finish:	No finish

Knee lining:	100% polyester taffeta lining in black
--------------	--

Pocket lining, inside fly and crotch reinforcement:	TC solid dyed poplin in Black colour 65% polyester, 35% cotton, 45x45/110x76 Weight: 105 gsm
---	--

Quality requirements for knee lining:

Test	Test method	Min. requirement
Dimension stability	ISO 5077:2007/ISO 6330:2012 4N (40 C), Normal flat dry	Warp max 2% Weft max 2%
Colour fastness to wash	SS-ISO 105-CO6:2010, A25 (40 C)	Change 4-5 Staining 4
Colour fastness to dry cleaning	SS-EN ISO 105-D01:2010	Change 4-5 Staining 4
Colour fastness to perspiration	SS-EN ISO 105-E04:2013	Change 4-5 Staining 4
Colour fastness to rubbing	SS-EN ISO 105-X12:2002	Dry 4 Wet 3-4
Seam Slippage	ISO 13936-2:2004 Load 60 N	Warp max 3 mm Weft max 3 mm
Abrasion	Martindale SS-EN ISO 12947-2, 9 kPa	Min 15000 turns
Pilling	Martindale SS-EN ISO 12945-2:2000	Grade 4/5000 turns



Quality requirements for shell fabric:

Test	Test method	Min. requirement
Dimension stability to wash 40°C 5A and tumble drying	SS-EN ISO 6330, SS-EN ISO 3759, SS-EN 25077	Warp max 2% Weft max 2%
Colour fastness to wash 40°C and dry cleaning; colour change staining	SS-EN ISO 105-CO6	min 4-5 min 4-5
Colour fastness to rubbing	SS-EN ISO 105-X12	Wet min 4 Dry min 4-5
Abrasion resistance 12 kPa	SS-EN ISO 12947-2	min 25000 revs
Pilling resistance, Martindale	SS-EN ISO 12945-2, assessment according to EMPA photographic W3	7000 varv/min 4
Tear strength, warp and weft N	SS-EN ISO 13937-2:2000	min 20N
Seam Slippage, warp and weft mm	SS-EN ISO 13936-2	max 1
Tensile strength	SS-EN ISO 13934-1:1999, N	Warp 400 Weft 400

Quality requirements for pocket lining:

Test	Test method	Min. requirement
Dimension stability	ISO 5077:2007/ISO 6330:2012 4N (40 C), Normal flat dry	Warp max 2% Weft max 2%
Colour fastness to wash	SS-ISO 105-CO6:2010, A25 (40 C)	Change 4-5 Staining 4
Colour fastness to dry cleaning	SS-EN ISO 105-D01:2010	Change 4-5 Staining 4
Colour fastness to perspiration	SS-EN ISO 105-E04:2013	Change 4-5 Staining 4
Colour fastness to rubbing	SS-EN ISO 105-X12:2002	Dry 4 Wet 3-4
Seam Slippage	ISO 13936-2:2004 Load 60 N	Warp max 3 mm Weft max 3 mm
Abrasion	Martindale SS-EN ISO 12947-2, 12 kPa	Min 15000 turns



Detail sketch

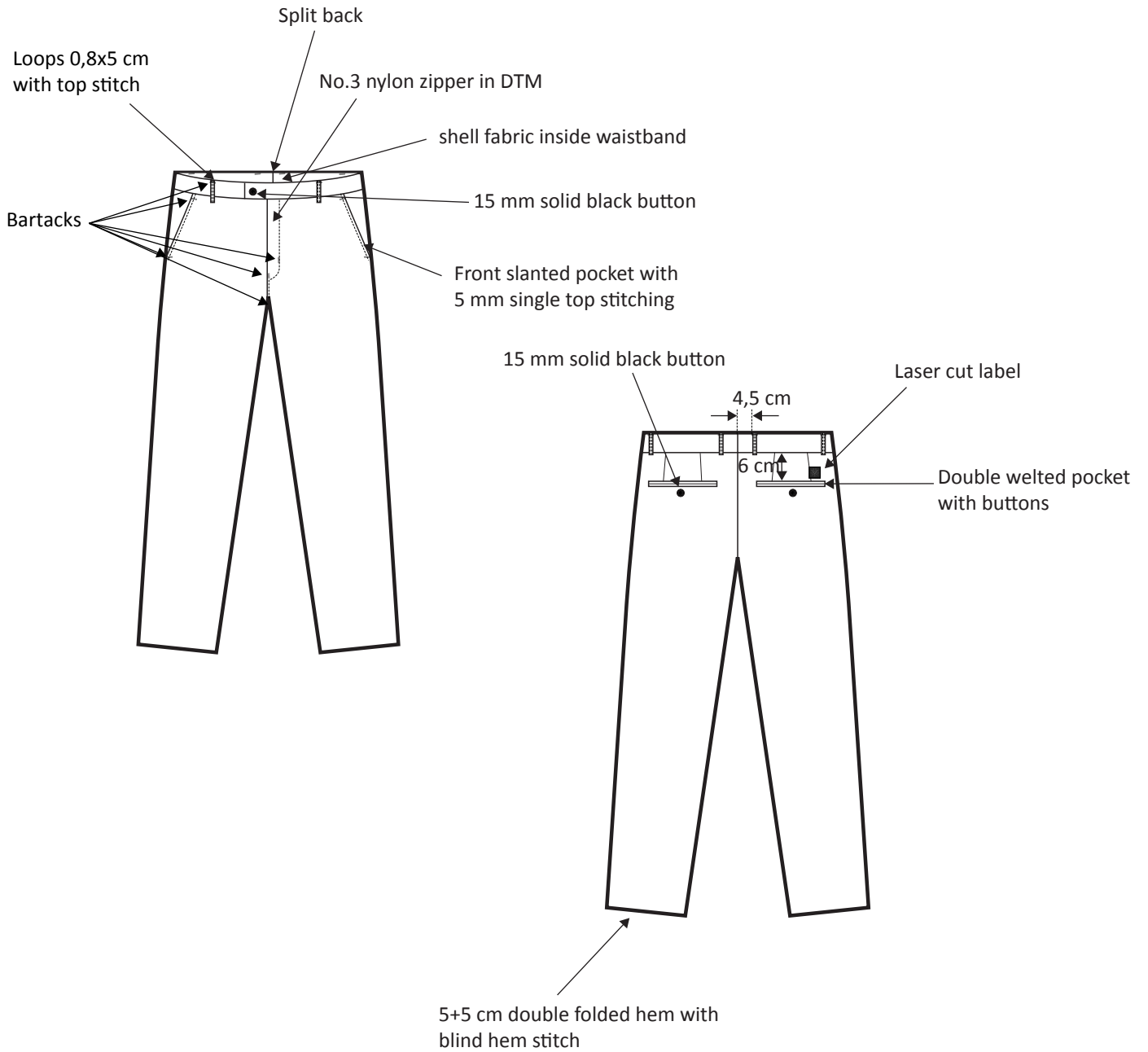



Inside detail sketch

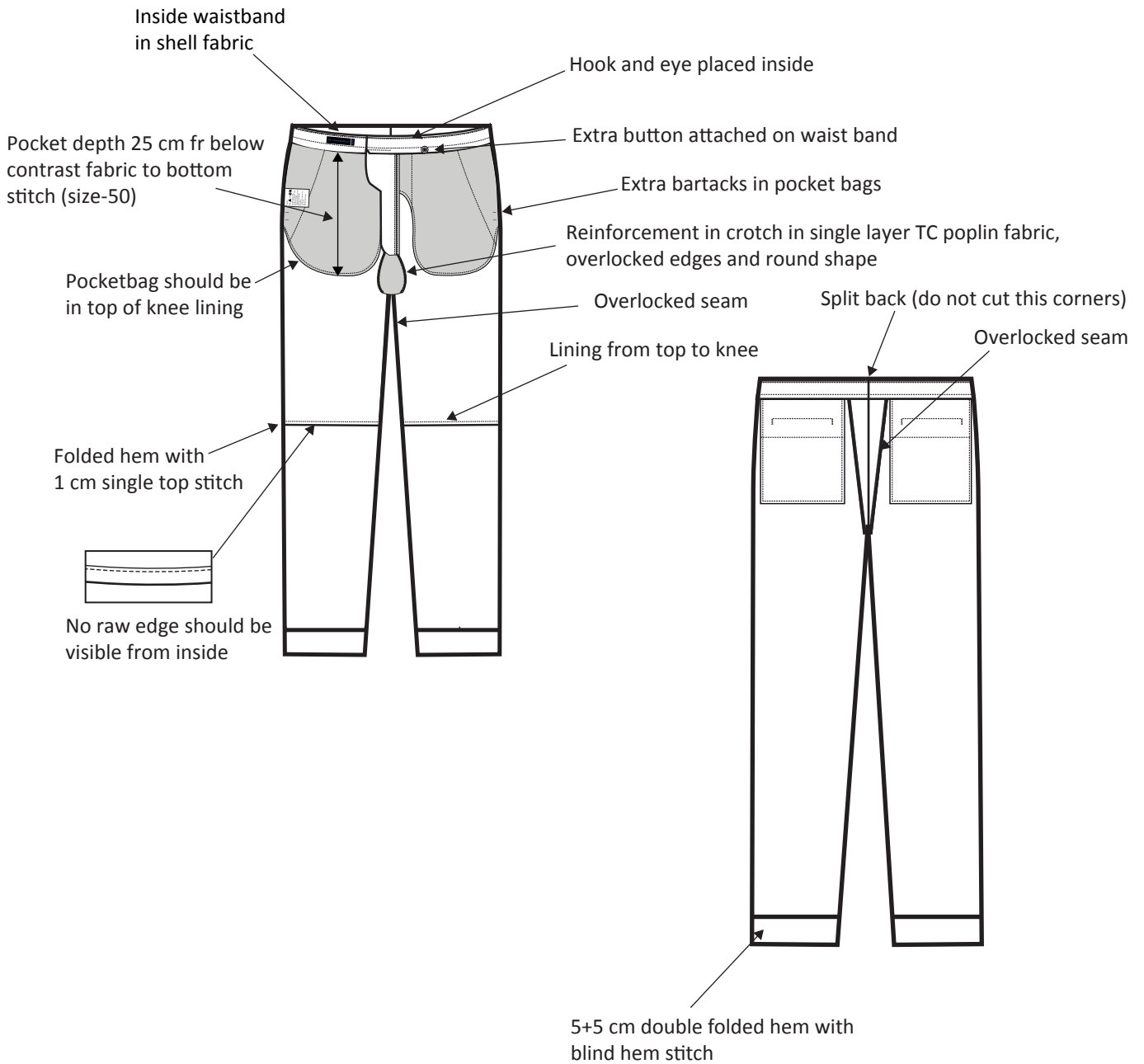



Detail sketch

Main label



Endfolded woven label
Placement LHS centered on inside waistband
10 cm from CF.
Stitched on both ends only.

Size label

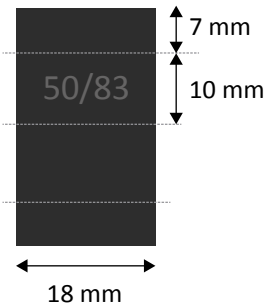

Midfolded woven size label
Placement LHS of main label.



Size label placement

Care label

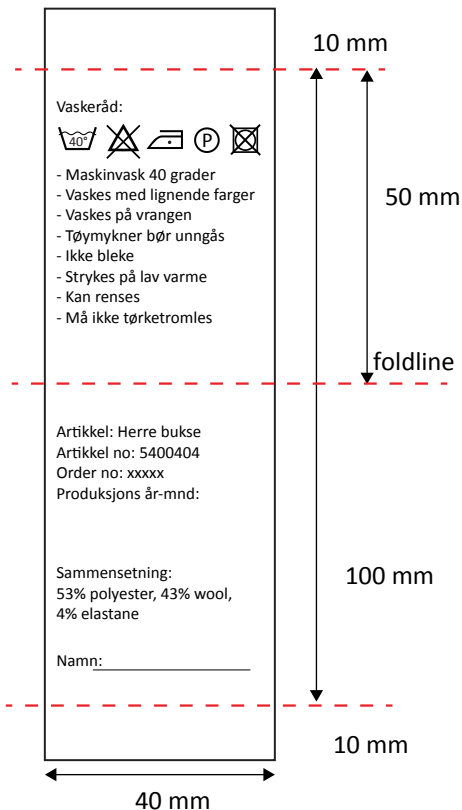

Care label in White background
with black printed text
Quality: Woven Satin
Placement on LHS side seam when wearing,
10 cm from bottom of waistband.
Fill in correct info acc to PO.

Laser cut label

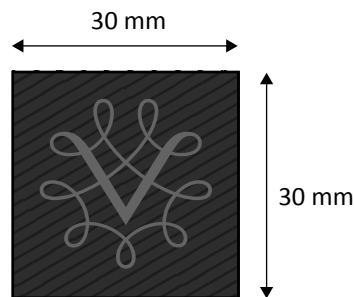

Laser cut label, stitched all around.
Placement on RHS back 1 cm above pocket, in line with
RHS edge of pocket.



BOM

Content	Description	Placement	Qty
Main fabric	53% polyester, 43% wool, 4% elastane	Body and inside waistband	
Insert fabric 1			
Insert fabric 2			
Lining	100% polyester taffeta lining in black	In front panel inside upto knee	
Pocket lining	65% polyester, 35% cotton black lining	At all Pocket bags and crotch	
Interlining 1	Poly/cotton woven fusible interlining, 105 gsm	At waistband	
Interlining 2	Poly/cotton woven non fusible interlining, 90 gsm	At under hook and bar	
Interlining 3	Polyester Non woven fusible interlining, 25 gsm	At slanting pkt facing (top+under layers), Single & double fly, front rise, back pkt body layer and beltloops	
Interlining 4	Non woven/ Non fuse interlining, 34 gsm	At back pocket velt	
Interlining 5			
Padding			
Rib 1			
Rib 2			
Tape 1			
Tape 2			
Tape 3			
Piping			
Binding			
Velcro tape 1			
Velcro tape 2			
Hang tag			
Reflective tape 1			
Reflective tape 2			
Button 1	15 mm solid black buttons	At front and back pockets	3
Button 2	Extra buttons	At waistband RHS when wearing	1
Button 3			
Zipper tape			
Zipper 1	No. 3 coil zipper in DTM	At fly	1
Zipper 2			
Zipper 3			
Puller 1			
Puller 2			
Buckle			
D-rings			
Rivets			
Stopper			
Cord			
Hook and eye	Silver colour metal hook and eye	At front	1
Main label	Endfolded woven label	LHS centered on inside wb 10 cm from CF	1
Size Label	Midfolded woven size label	LHS of main label	1
Thin label			
Logo label	Laser cut label	On RHS back pocket top	1
Logo zippuller			
Care label	Printed woven satin label	On LHS side seam	1
Hang loop			
Thread 1	100% polyester core-spun thread in DTM		
Thread 2			
Thread 3			



Measurement list

	Men's trousers (5400404 B2)	44/79	46/79	48/79	50/79	52/79	54/79	56/79	58/79	60/79	62/79	64/79
A.	Waist	79	83	87	91	95	100	105	111	117	123	129
B.	Seat, 2/3 of front rise	96	100	104	108	112	116	120	124	128	132	136
C.	Thigh	62	64	66	68	70	72	74	76	78	80	82
D.	Knee (at 1/2 inseam+5 cm up)	40.5	42	43.5	45	46.5	48	49.5	51	52.5	54	55.5
E.	Bottom of leg	36	37	38	39	40	41	42	43	44	45	46
F.	Front rise, ex WB	22.5	23	23.5	24	24.5	25	25.5	26	26.5	27	27.5
G.	Back rise, ex WB	33.5	34.5	35.5	36.5	37.5	38.5	39.5	40.5	41.5	42.5	43.5
H.	Wasitband height	4	4	4	4	4	4	4	4	4	4	4
I.	Zipper length	16	16	16	16	16	17	17	17	17	17	17
J.	Inseam	79	79	79	79	79	79	79	79	79	79	79
K.	Pocket along SS	16	16	16	16.5	16.5	16.5	17	17	17	17.5	17.5
L.	Pocket along WS	4.5	4.5	4.5	4.5	4.5	4.5	4.5	4.5	4.5	4.5	4.5
M.	Back pocket opening	12.5	12.5	13	13	13.5	13.5	14	14	14.5	14.5	15
N.	Front pocket bag depth	24.5	24.5	24.5	25	25	25	25.5	25.5	25.5	26	26
O.	Back pocket bag depth	19	19	19	19	19	19	19	19	19	19	19

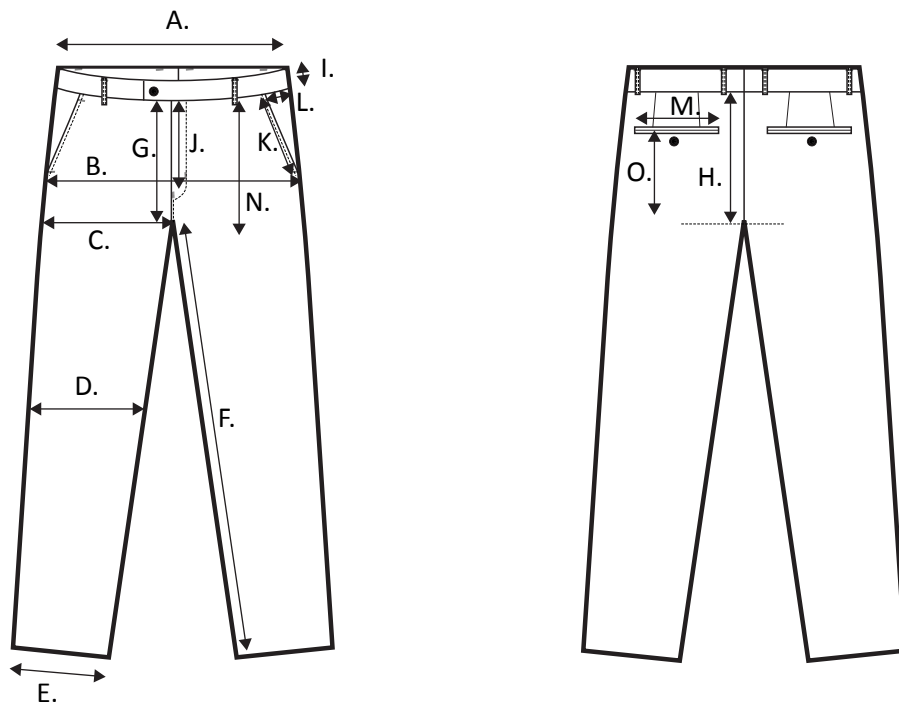



Principle for folding (adjust when necessary)

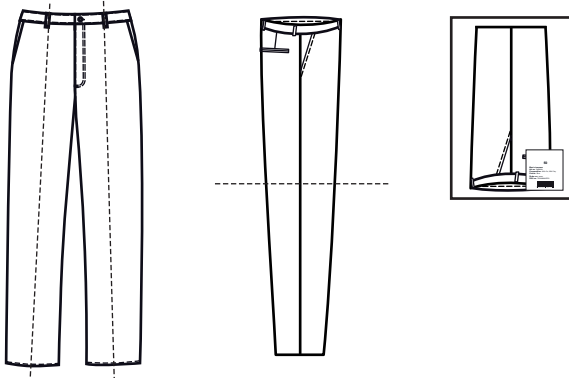

Paper sticker for poly bag

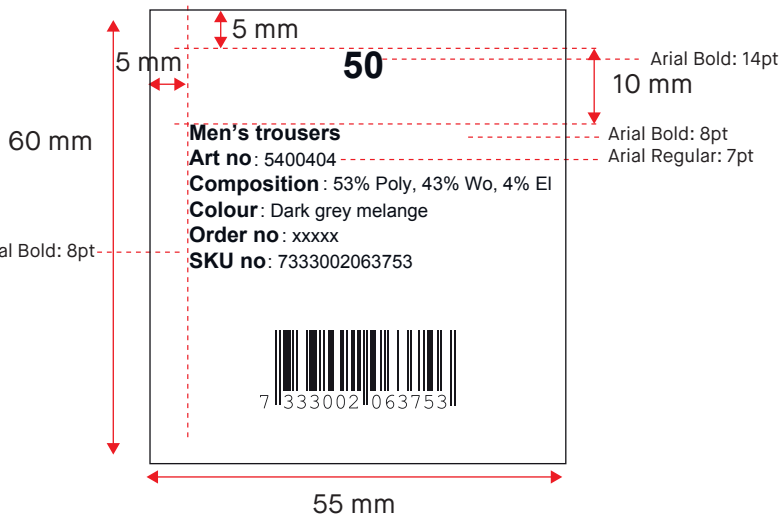

Placement on PE or PP poly bag

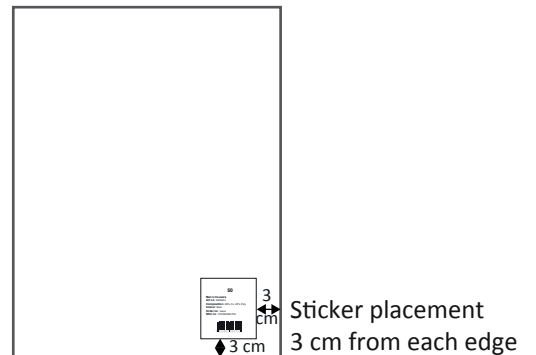

Kindly fill in the correct information for size, model, article no, colour no and order no.
 Please send an artwork of all labels for approval before printing.

Carton marks

Use 5 ply automatic corrugated cartons
 size 20 x 30 cm

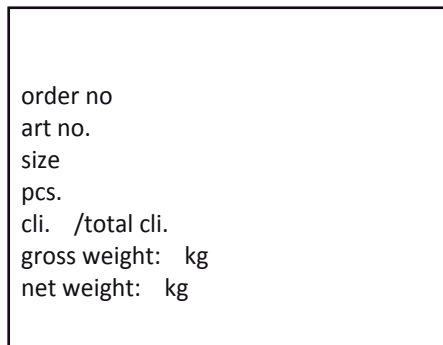

Carton size

size 40 x 60 x 40 cm

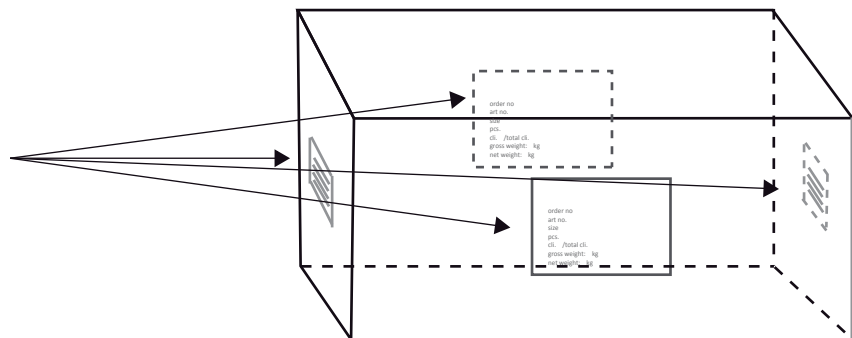

Kindly fill in the correct information according to PO.
 Placement on short ends and front of carton.

technical specification
Vinmonopolet
model. men's trousers
art no. 5400404



SM VINMONOPOLET

2021-09-01

Adjustment log