

POS. 4.2
PAPER TWIST INSTALLATION - CONNESTION TO EXHIBIT
 MODULE B

PAPER TWIST INSTALLATION SEE PLAN 1.4.1.0_04

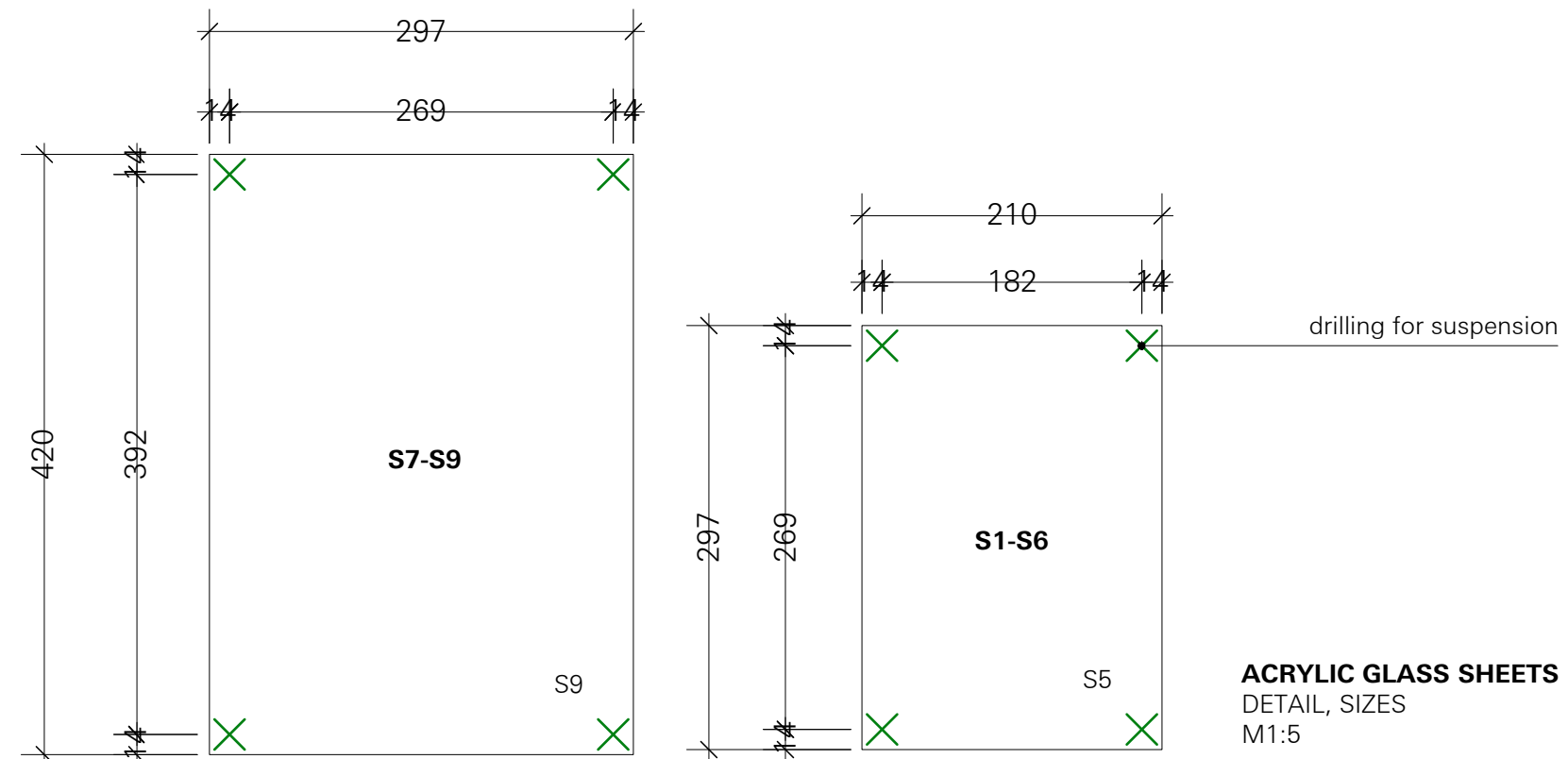
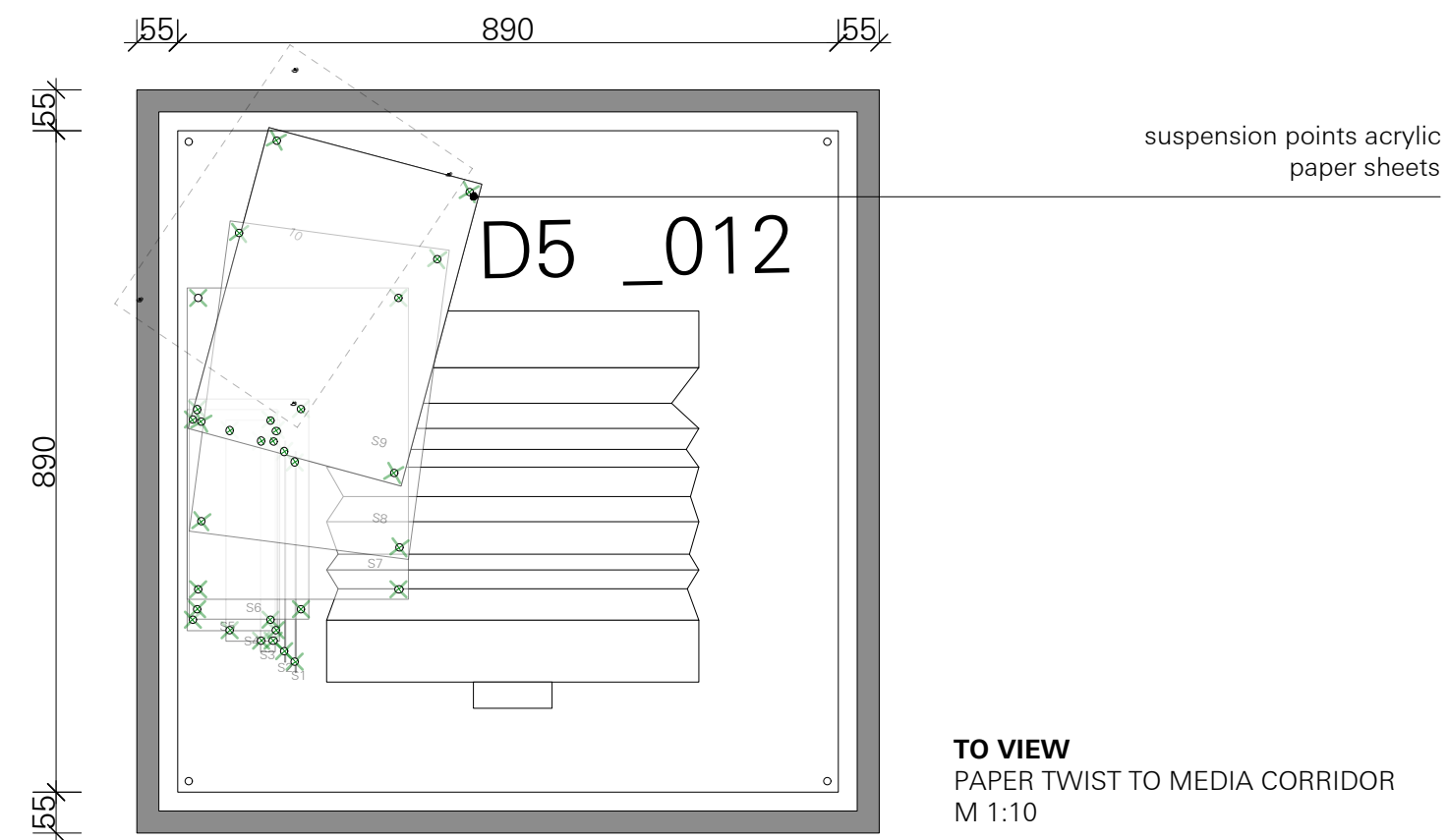
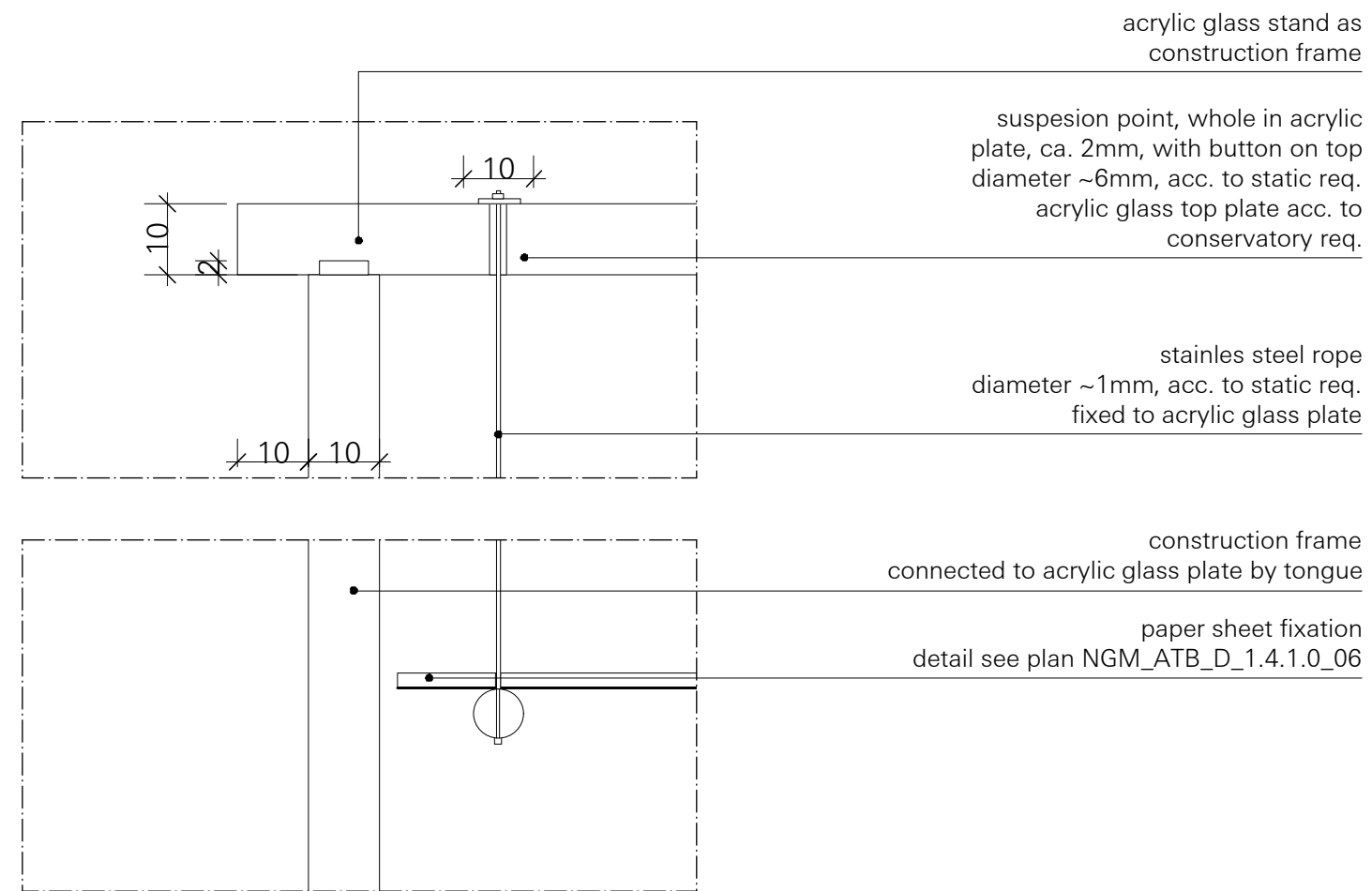
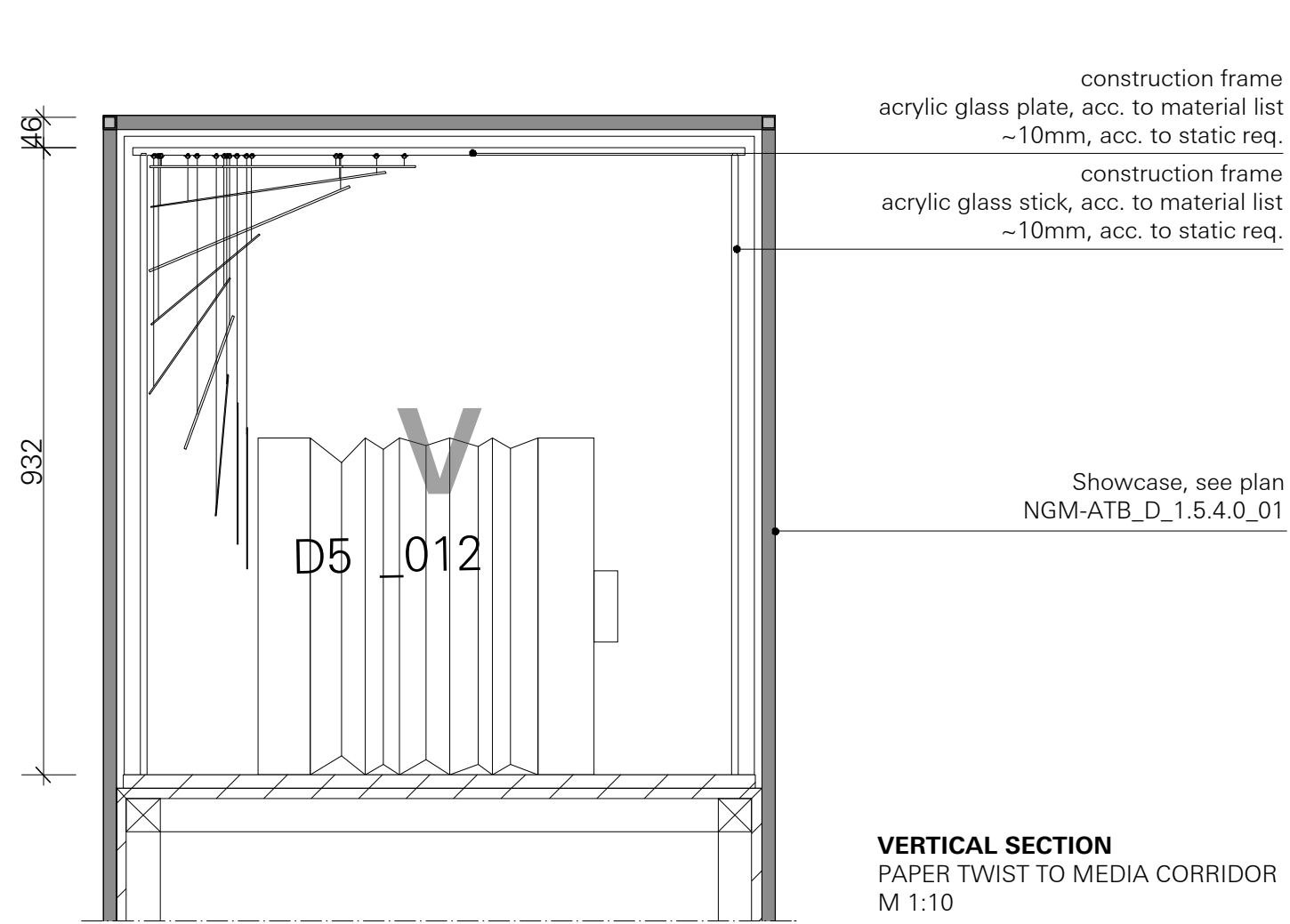

sheet number	height lower edge (from upper edge showcase bottom plate)	height upper edge (from upper edge showcase bottom plate)
S1	306mm	516mm
S2	343mm	553mm
S3	385mm	594mm
S4	484mm	682mm
S5	566mm	739mm
S6	668mm	805mm
S7	748mm	874mm
S8	843mm	895mm
S9	903mm	905mm

SUSPENSION HEIGH
 SHOWCASE SHEETS

LEGEND

SPECIALISTS

M	MEDIEN
G	GRAPHIC
L	LIGHT
TGA	BUILDING TECHNOLOGY
	EXHIBITION ATB

RELEASED

All measurements have to be revised carefully by the contractor/executor and compared with on-site situations. Differences concerning measurements or planning / stock have to be conveyed immediately to the designer. Details and drawings are only valid with annotation of approval by the designer.



NORWEGIAN PRINTING MUSEUM
 STAVANGER

KEY PLAN

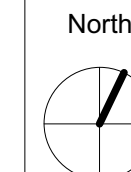
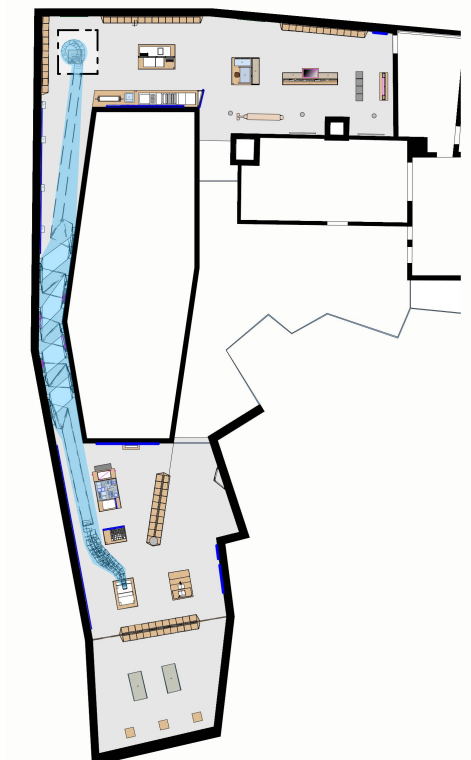

PAPER TWIST INSTALLATION
 MODULE B - CONNECTION TO EXHIBIT

client **Museum Stavanger**
 Øvre Strandgate 88
 4005 Stavanger I Norwegian
 T. +47 40 60 17 01
 www.museumstavanger.no
 bitten.bakke@museumstavanger.no

planner exhibition scenography **ATELIER BRÜCKNER GMBH**
 Krefelder Strasse 32
 70376 Stuttgart I Germany
 T. +49 711 5000 77 116
 F. +49 711 5000 77 22
 ngm@atelier-brueckner.com

papersize scale unit sign
DIN A2 1:1, 1:10 mm sm

filename
NGM-ATB_D_1.4.1.0_05

date code planningphase
13.09.2019 NGM-ATB LPH 4 - DD

type hierarchy no. index
D 1.4.1.0 05 00