

**POS. 5.6**  
**SHOWCASE (OPTIONAL)**  
MODULE F

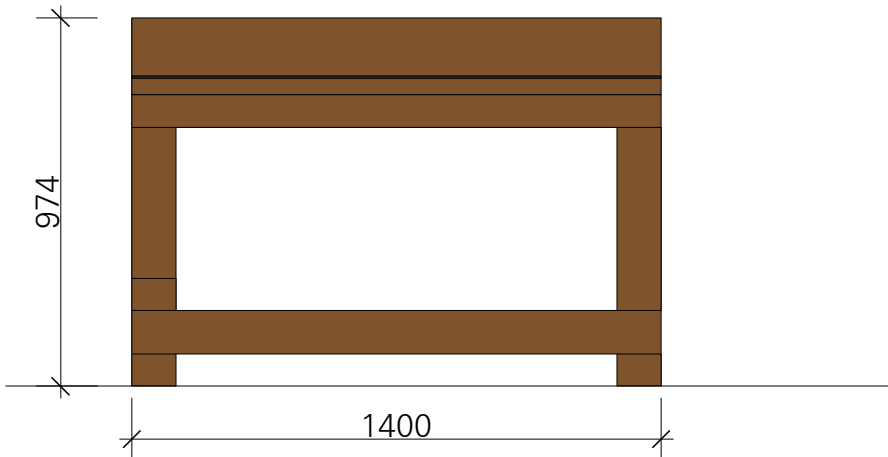

**SHOWCASE**  
FRONT VIEW  
M 1:20

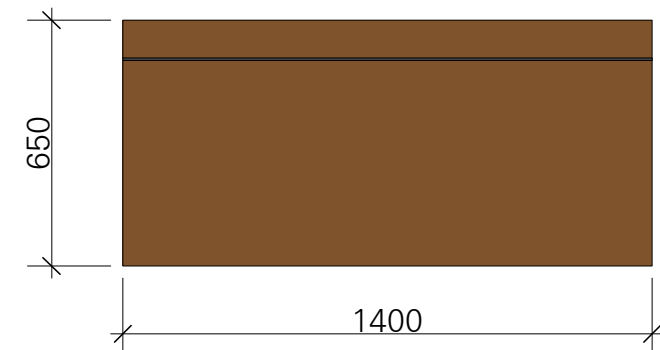

**SHOWCASE**  
TOP VIEW  
M 1:20



**SHOWCASE**  
CONTENT/EXHIBITS  
M 1:20

Papir  
showcase  
appr. A2

Sketch:  
Ca. 60 x 40 cm  
Book case:  
Corresponding to the book

Book:  
20 x 25 x 5 cm

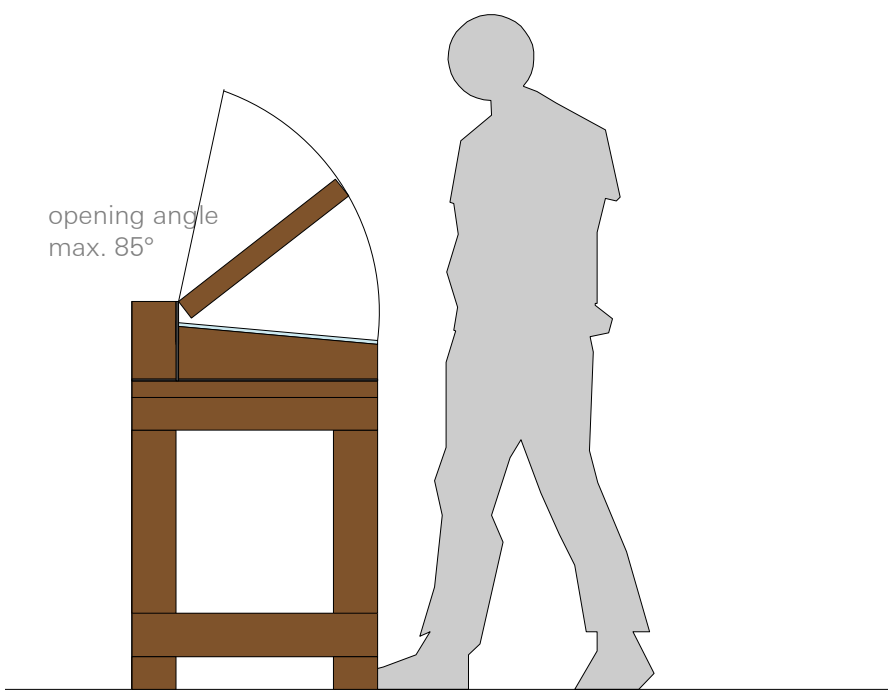

**SHOWCASE**  
SIDE VIEW  
M 1:20

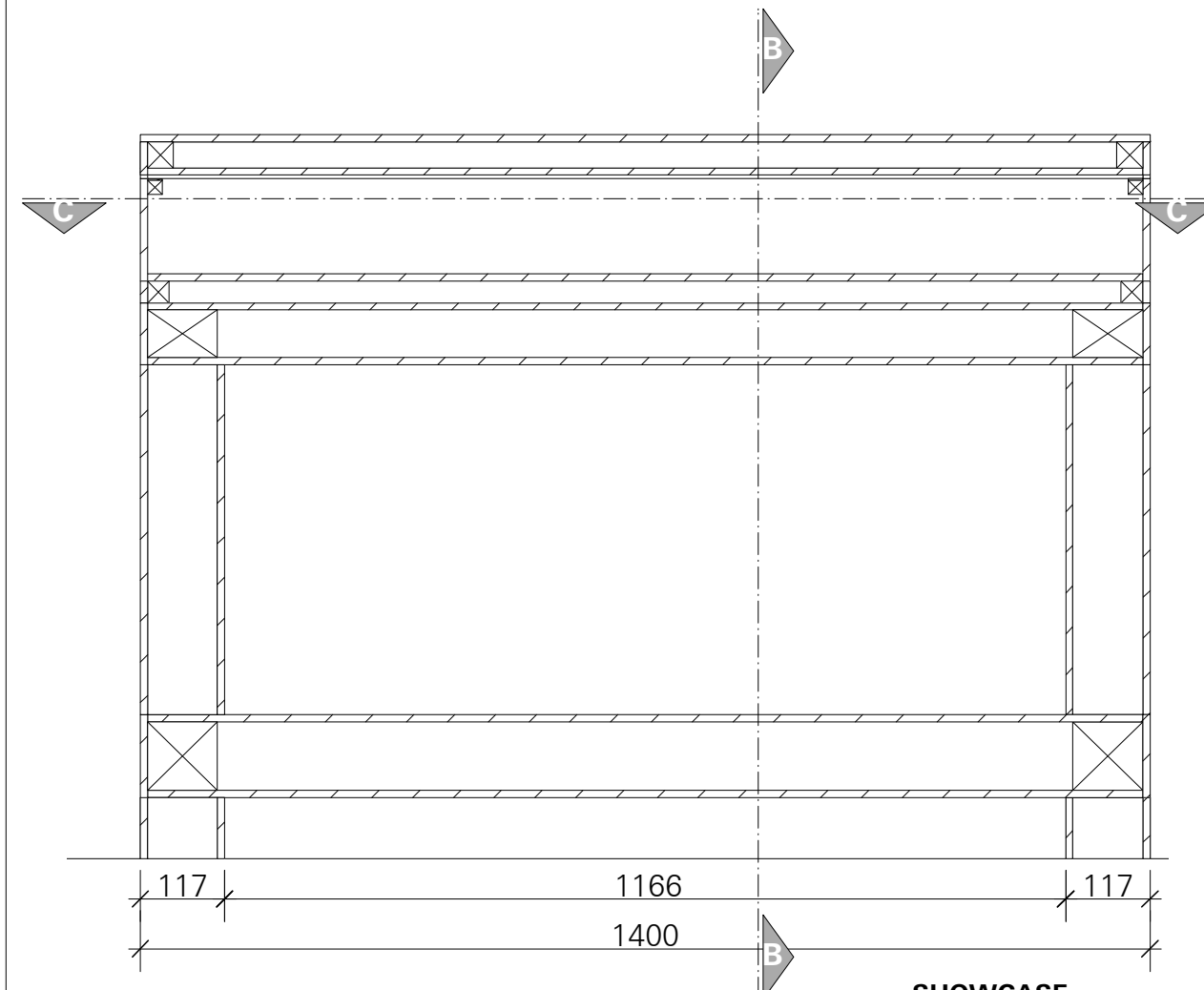

**SHOWCASE**  
VERTICAL SECTION A  
M 1:10

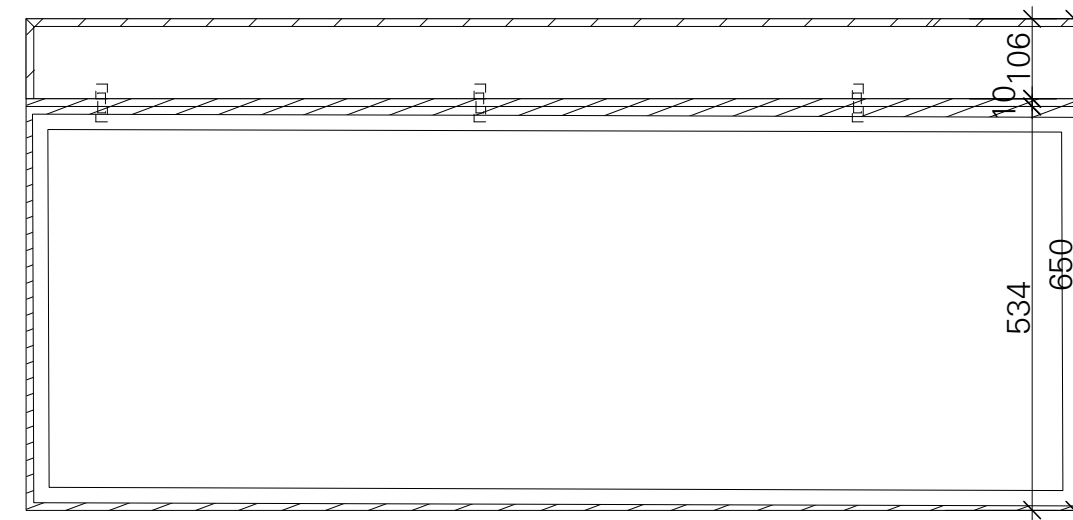

**SHOWCASE**  
HORIZONTAL SECTION C  
M 1:10

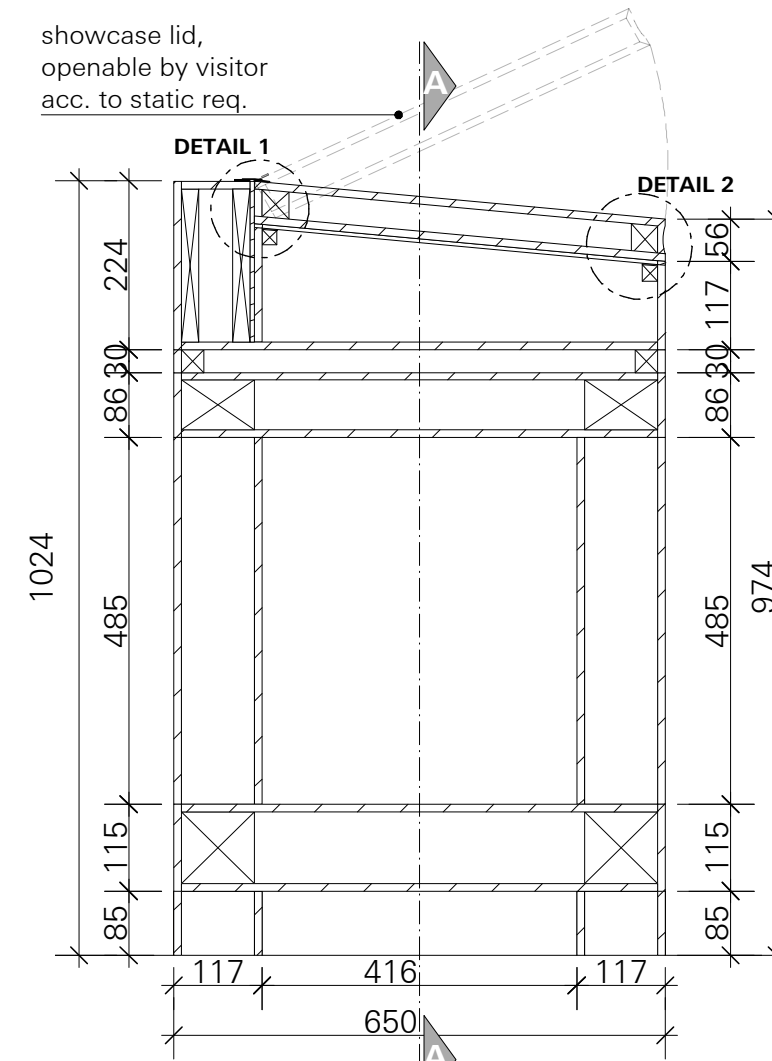

**SHOWCASE**  
VERTICAL SECTION B  
M 1:10

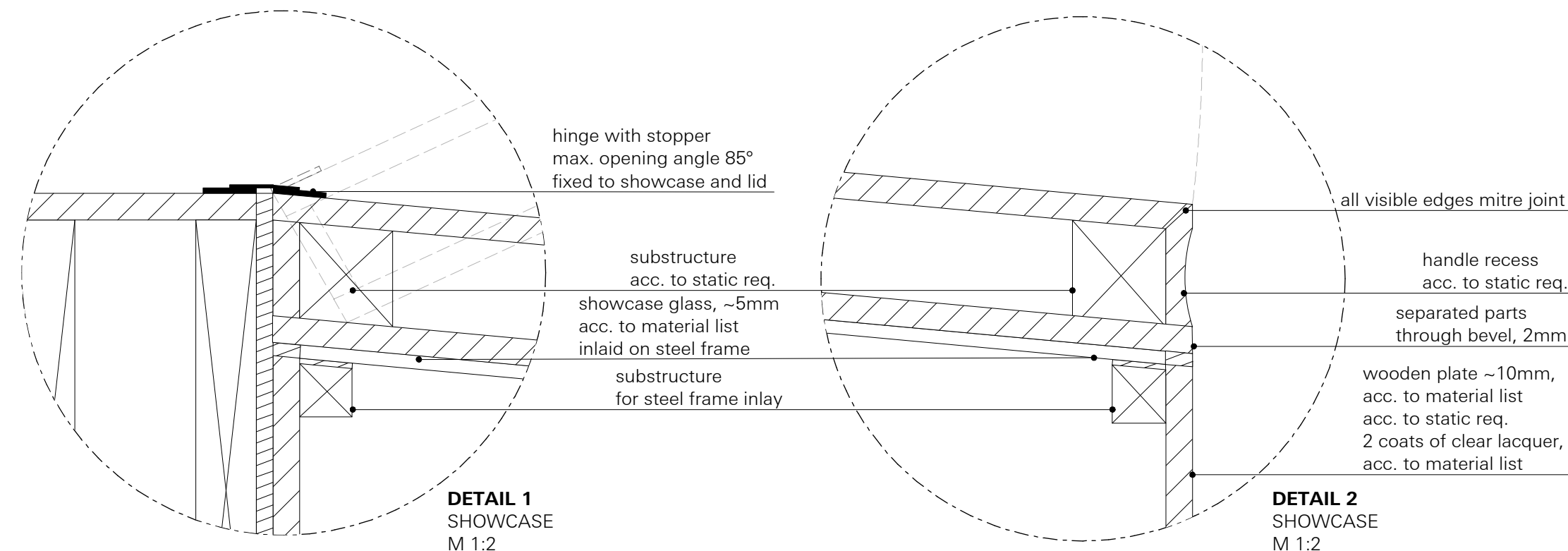

**DETAIL 1**  
SHOWCASE  
M 1:2

**DETAIL 2**  
SHOWCASE  
M 1:2

**LEGEND**

**SPECIALISTS**

M	MEDIEN
G	GRAPHIC
L	LIGHT
TGA	BUILDING TECHNOLOGY
EXHIBITION ATB	EXHIBITION ATB

X = power markings

**RELEASED**

All measurements have to be revised carefully by the contractor/executor and compared with on-site situations. Differences concerning measurements or planning / stock have to be conveyed immediately to the designer. Details and drawings are only valid with annotation of approval by the designer.

**NORWEGIAN PRINTING MUSEUM**  
STAVANGER

**KEY PLAN**

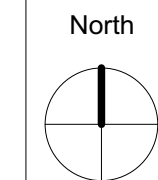
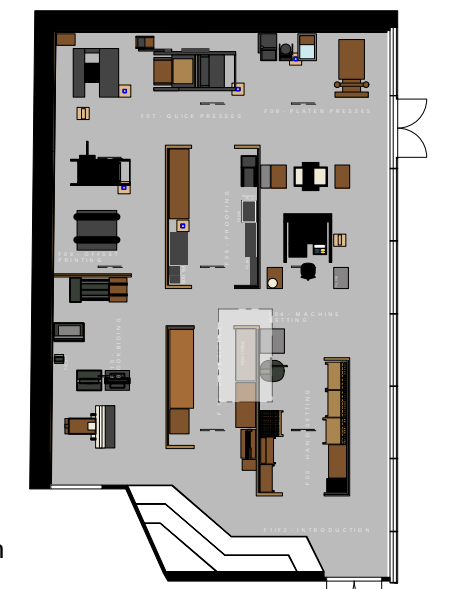

**DETAIL PLAN - SHOWCASE**  
SECOND FLOOR

**client** **Museum Stavanger**  
Øvre Strandgate 88  
4005 Stavanger I Norwegian  
T. +47 40 60 17 01  
www.museumstavanger.no  
bitten.bakke@museumstavanger.no

**planner exhibition scenography** **ATELIER BRÜCKNER GMBH**  
Krefelder Strasse 32  
70376 Stuttgart I Germany  
T. +49 711 5000 77 116  
F. +49 711 5000 77 22  
ngm@atelier-brueckner.com

papersize	scale	unit	sign
<b>DIN A2</b>	<b>1:2, 1:10, 1:20</b>	<b>mm</b>	<b>sm</b>

filename  
**NGM-ATB\_D\_2.1.5.0\_01**

date	code	planningphase
<b>13.09.2019</b>	<b>NGM-ATB</b>	<b>LPH 4 - DD</b>

type	hierarchy	no.	index
<b>D</b>	<b>2.1.5.0</b>	<b>01</b>	<b>00</b>