

SECTION_DET1

Lettercase shelf / Backlit object_Lighting panel
1:5

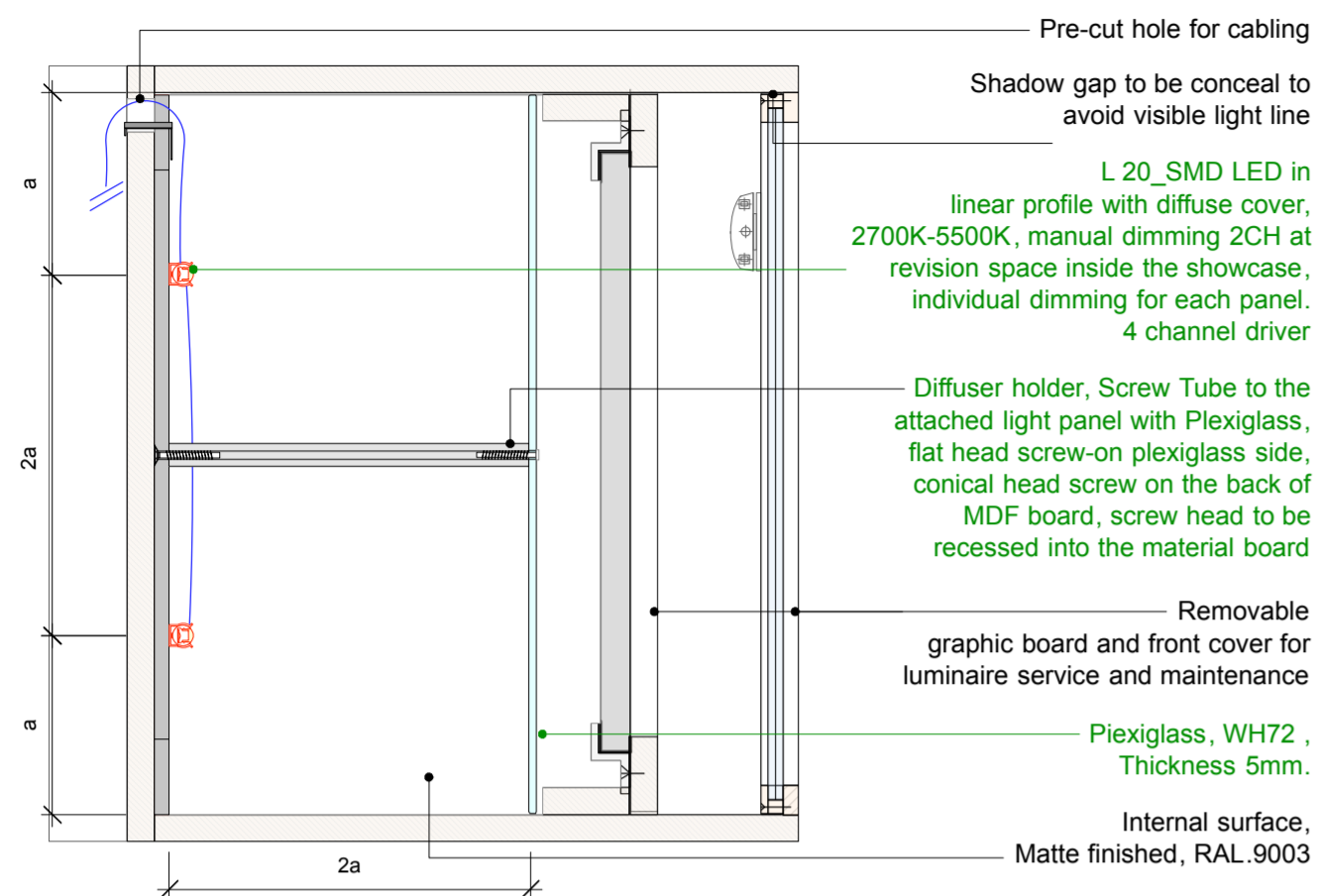

SECTION_DET2

Lettercase shelf / Backlit image_Lighting panel
1:5

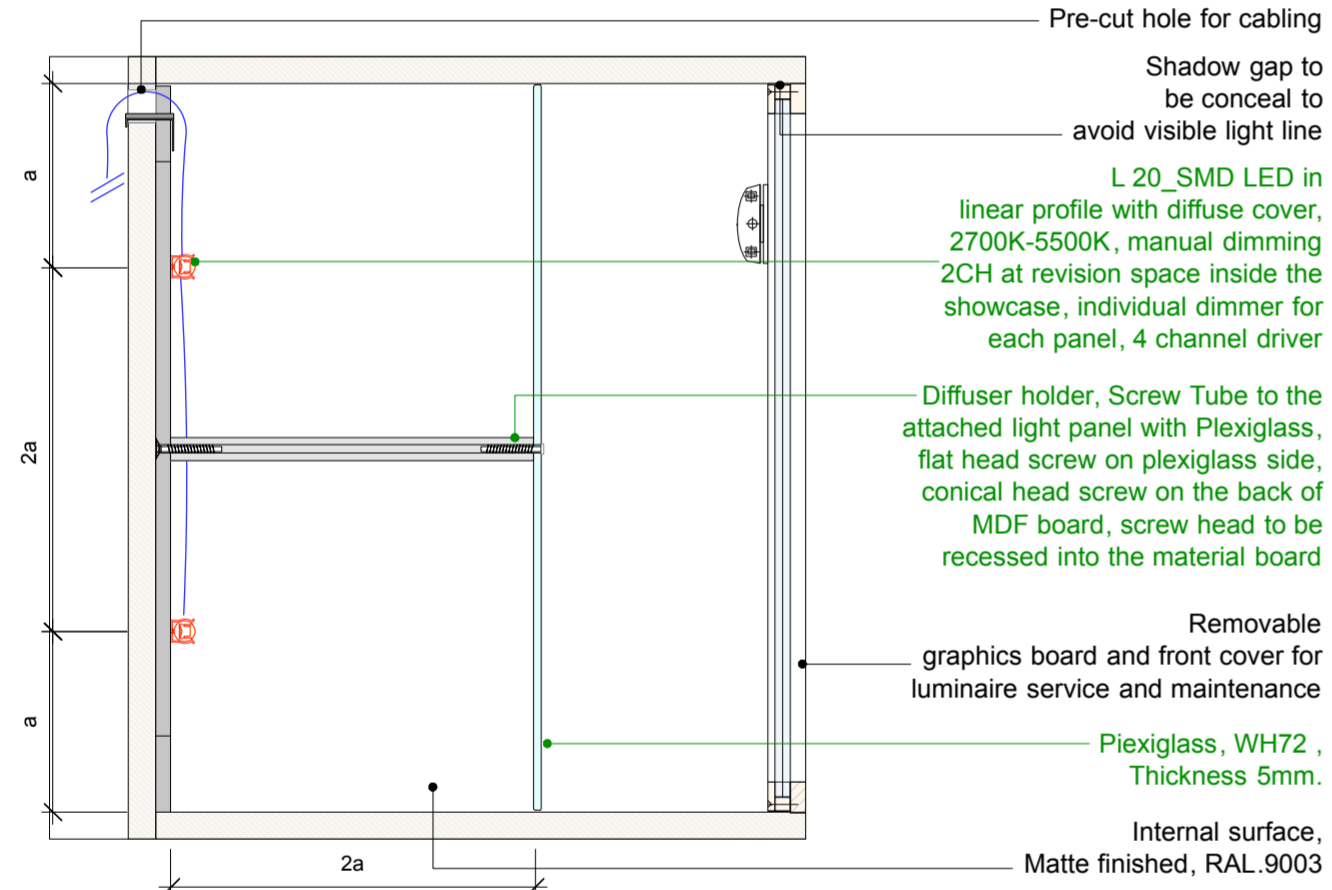

ELEVATION_DET3

Lettercase shelf / Backlit object, Backlit image_Lighting panel
1:5

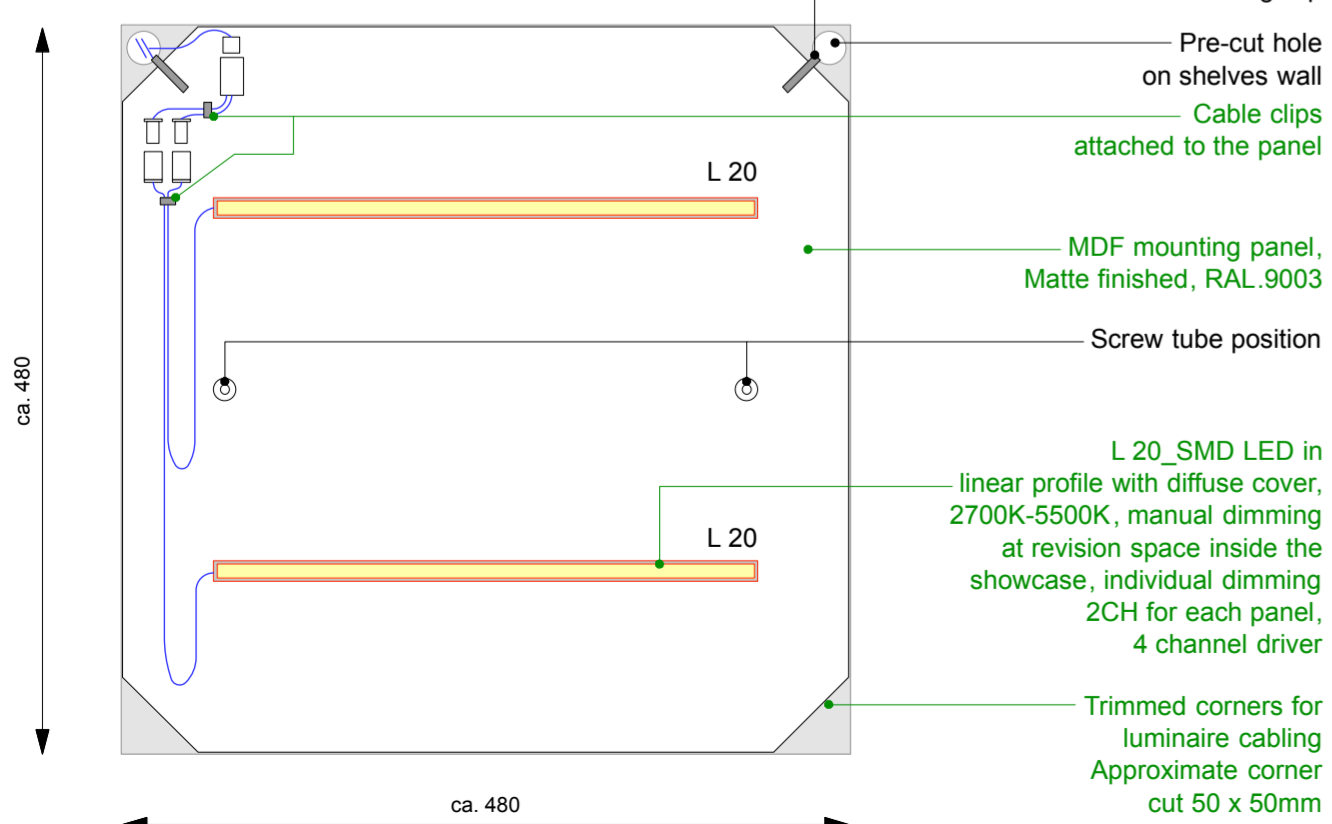

SECTION_DET4

Lettercase shelf / Cube game
1:5

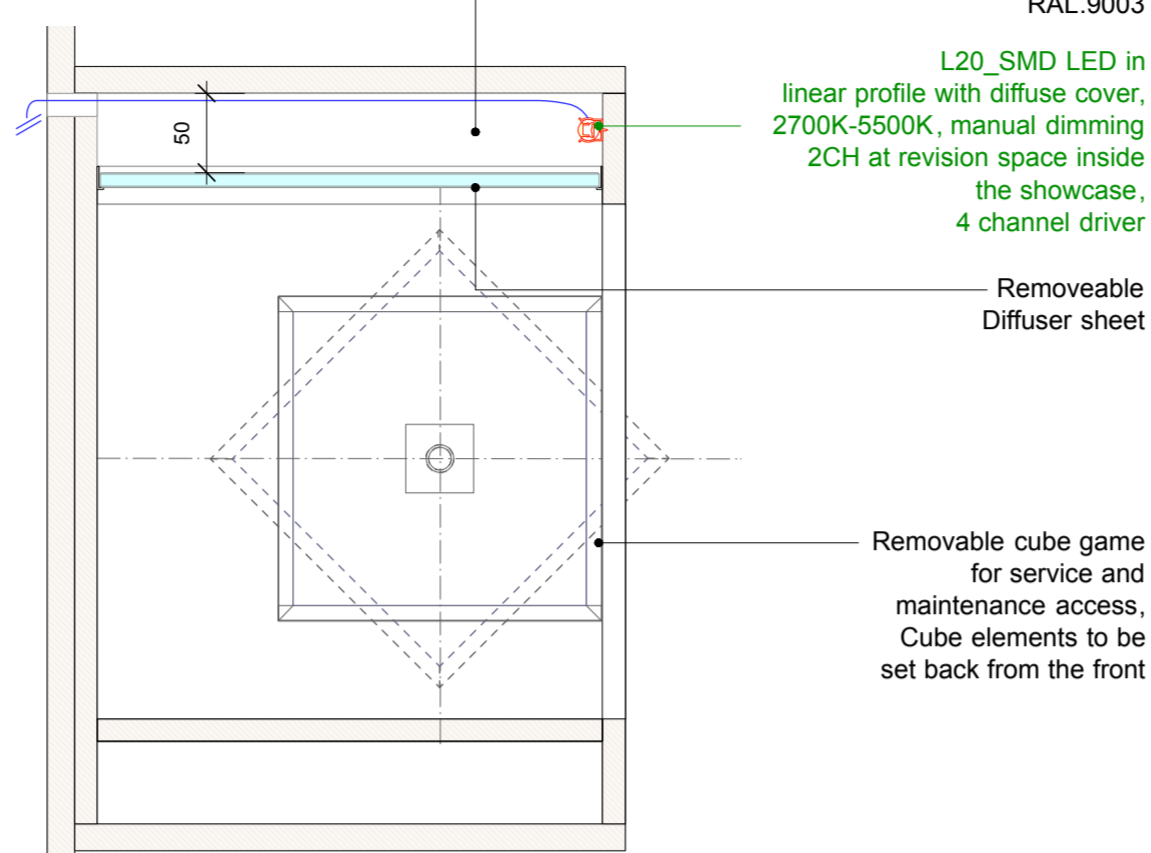

SECTION_DET5

Lettercase shelf / Open shelf
1:5

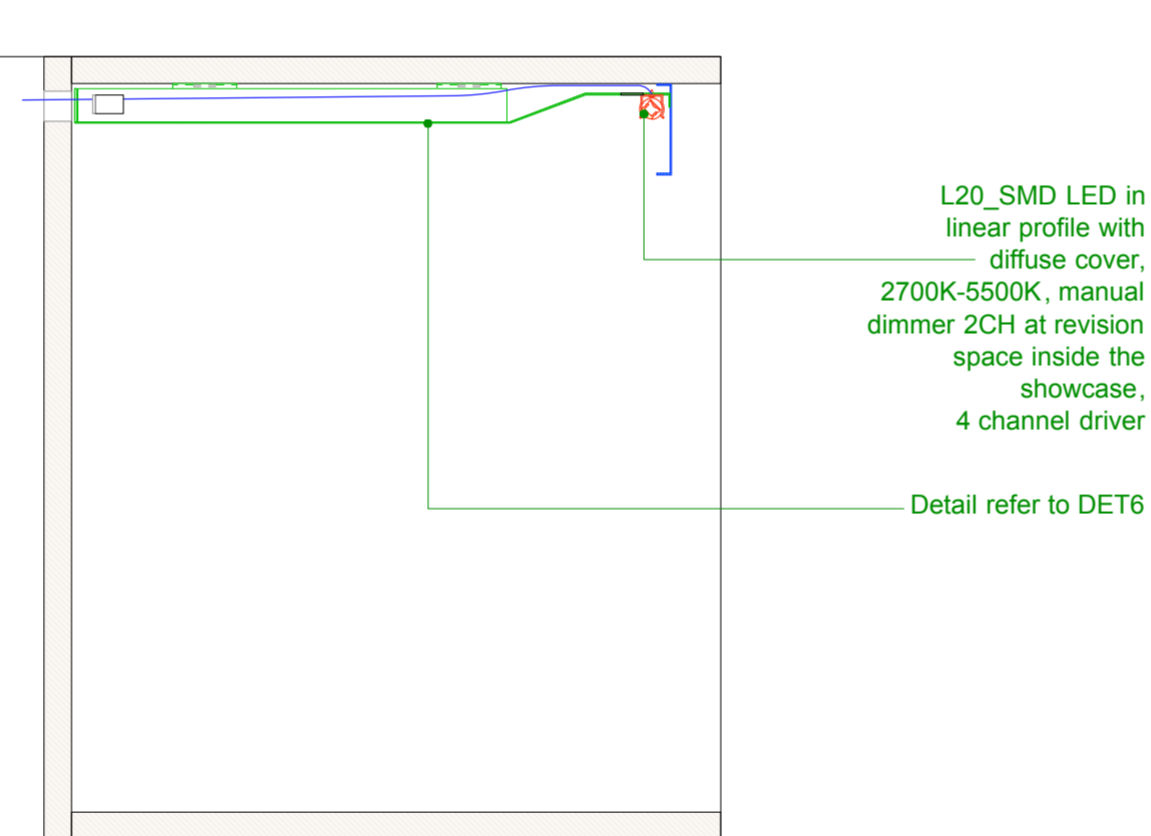

ISOMETRIC

Lighting panel and diffuser sheet
1:5

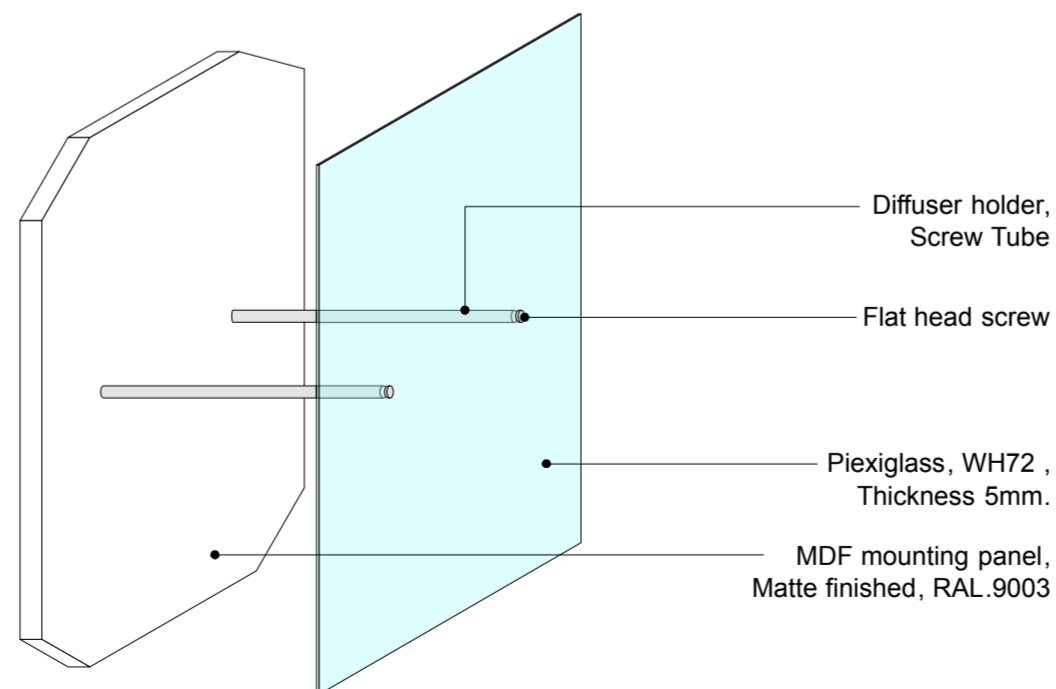

**Prototype mock-up is requested

LEGEND

SPECIALISTS

M	MEDIEN
G	GRAPHIC
L	LIGHT
TGA	BUILDING TECHNOLOGY
EXHIBITION ATB	EXHIBITION ATB

PRELIMINARY

MUST
MUSEUM STAVANGER

NORWEGIAN PRINTING MUSEUM
STAVANGER

KEY PLAN

North

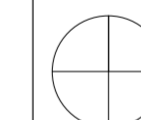

AREA PLAN **OVERALL AREA**
Shelves_Backlit object-image, Cube game, Openshelf

client Museum Stavanger
Øvre Strandgate 88
4005 Stavanger | Norwegian
T. +47 40 60 17 01
www.museumstavanger.no
bitten.bakke@museumstavanger.no

planner exhibition scenography ATELIER BRÜCKNER GMBH
Krefelder Strasse 32
70376 Stuttgart | Germany
T. +49 711 5000 77 116
F. +49 711 5000 77 22
ngm@atelier-brueckner.com

papersize	scale	unit	sign
DIN A2	N/A	mm	sm

filename
NGM-ATB_D_1.1.0.0_03

date	code	planningphase
02.09.2019	NGM-ATB	LPH 4 - DD

type	hierarchy	no.	index
D	1.1.0.0	03	00