

**SPECIAL DESIGN SHELF COMPONENTS**  
MODULE D7

**Pos. 1.7.9**  
**DOUBLE SHELF**  
**D7\_134**

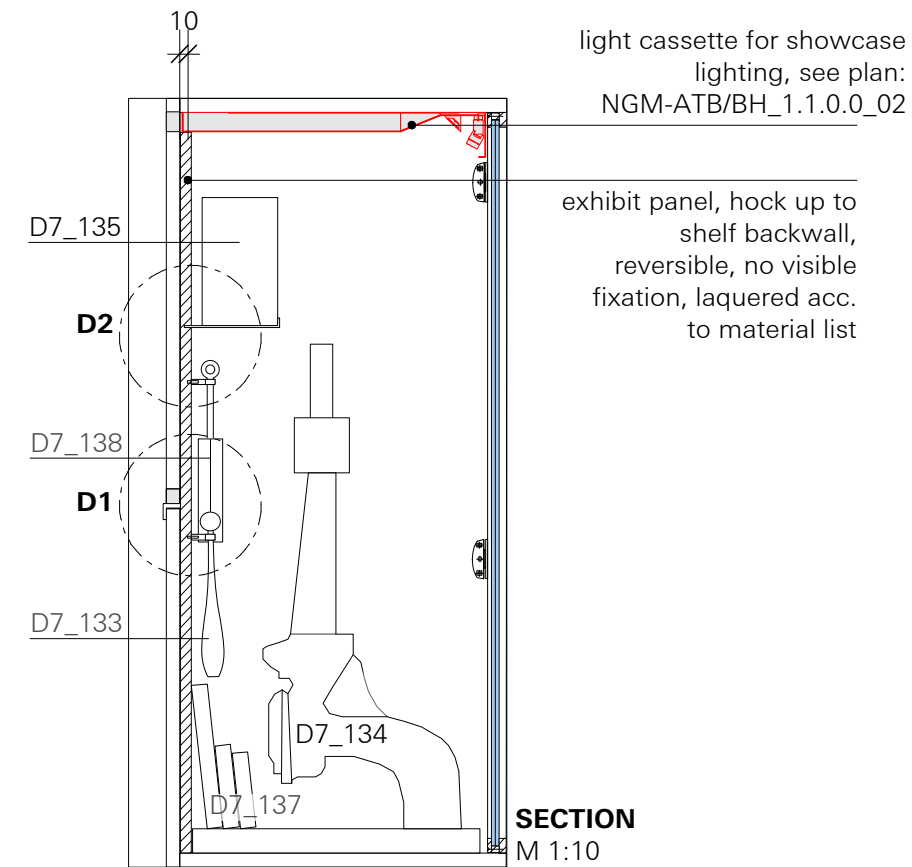
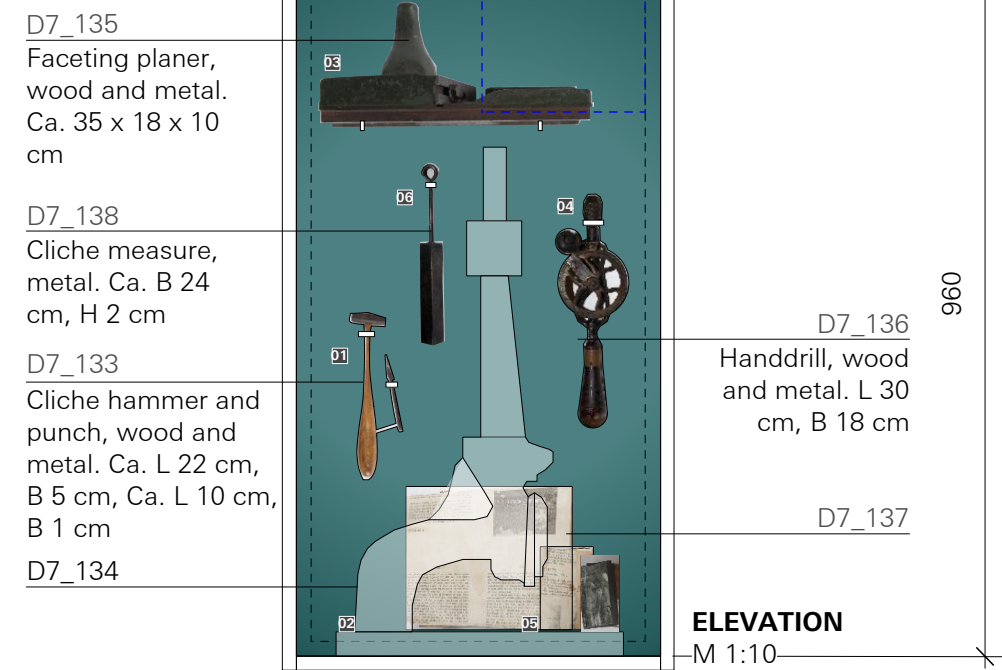

GENERAL CONSTRUCTION DETAIL OF LETTERCASE SHELF PLEASE SEE PLAN:  
NGM-ATB\_D\_1.0.1.0\_01  
NGM-ATB\_D\_1.0.2.0\_01

All object holders acc. to conservatroty requirements

**Pos. 1.7.10**  
**SINGLE SHELF**  
**D7\_151**

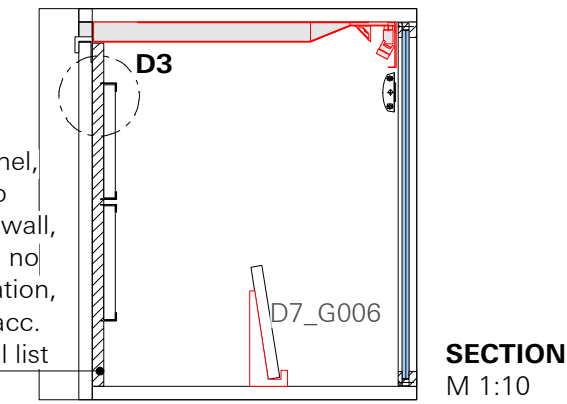
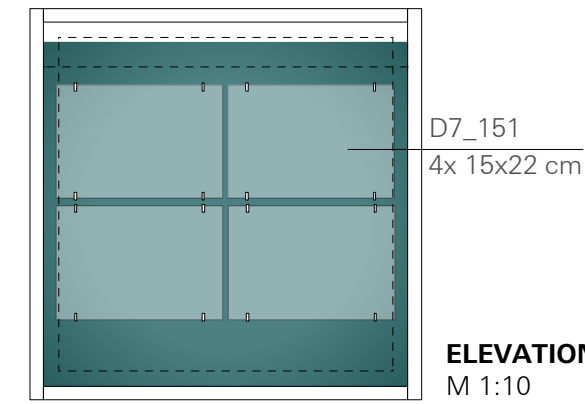

exhibit panel, hock up to shelf backwall, reversible, no visible fixation, laquered acc. to material list

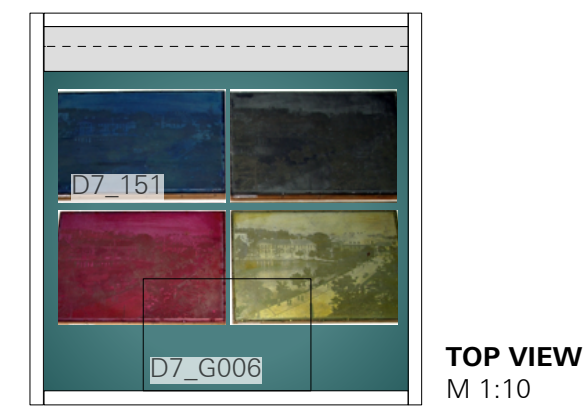
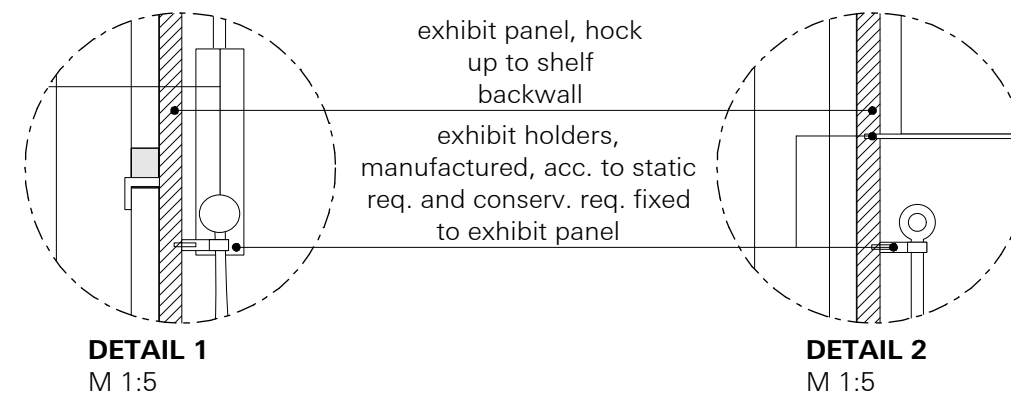
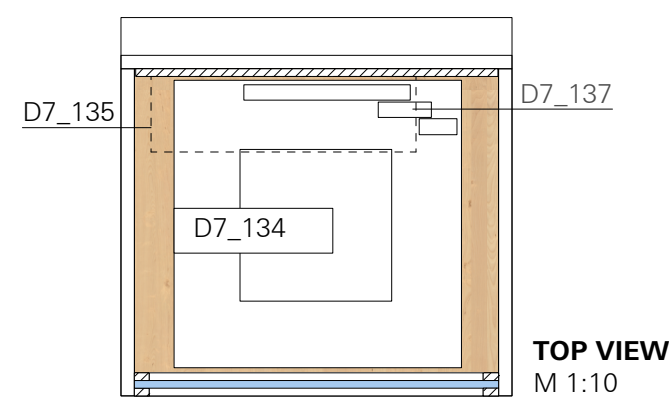
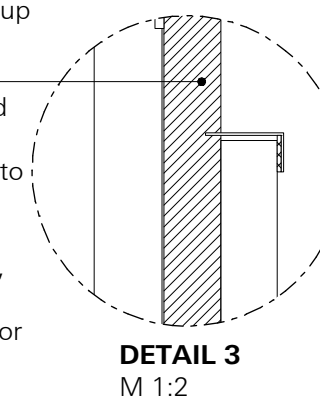
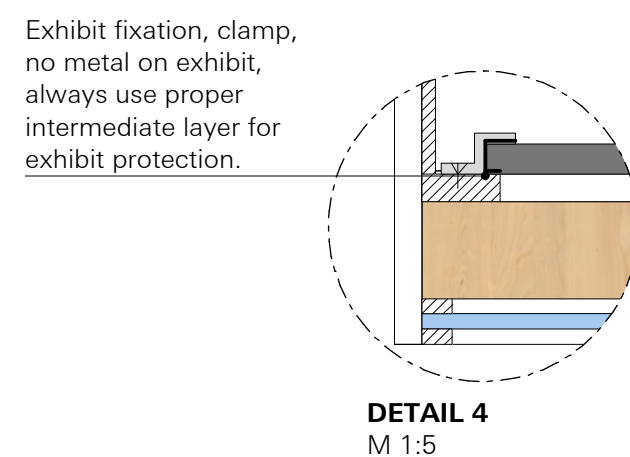
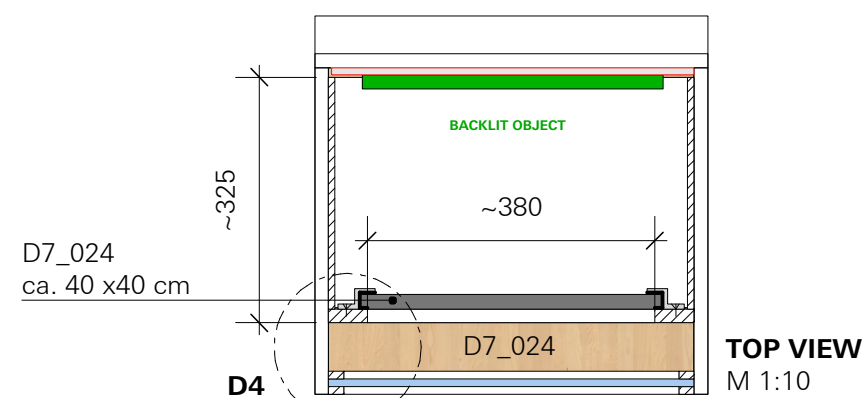
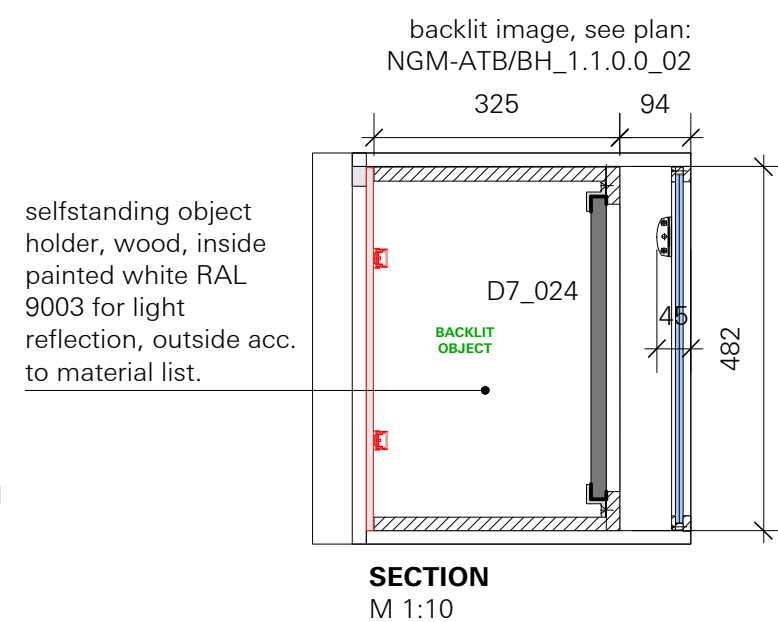
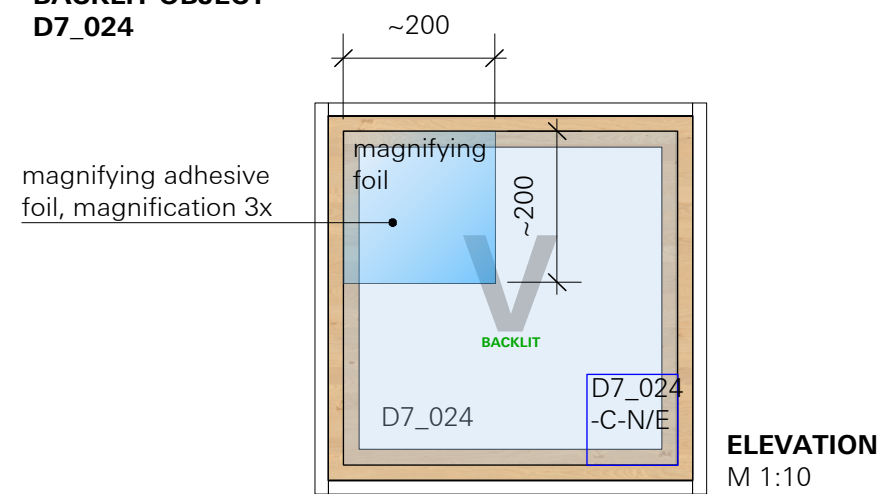

exhibit panel, hock up to shelf backwall.

exhibit holders, fixed to exhibit panel, manufactured acc. to static req. and conserv. req. no metal on exhibit, always use proper intermediate layer for exhibit protection.



**Pos. 1.7.8**  
**BACKLIT OBJECT**  
**D7\_024**



**Pos. 1.7.7**  
**GENERAL DETAIL**  
**FACT BOX**

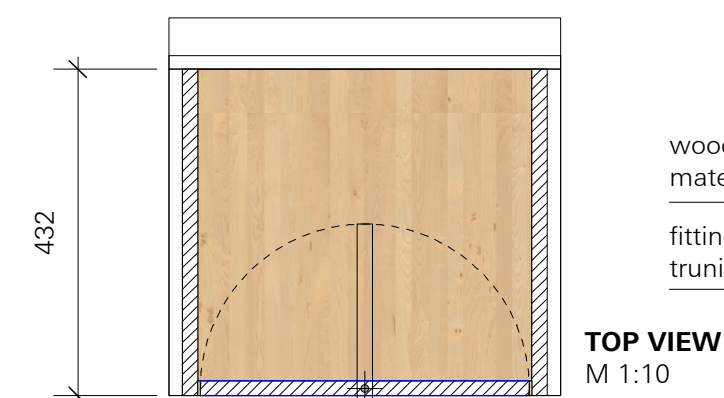
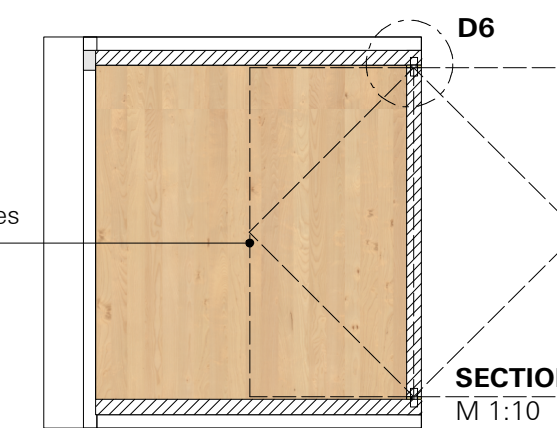
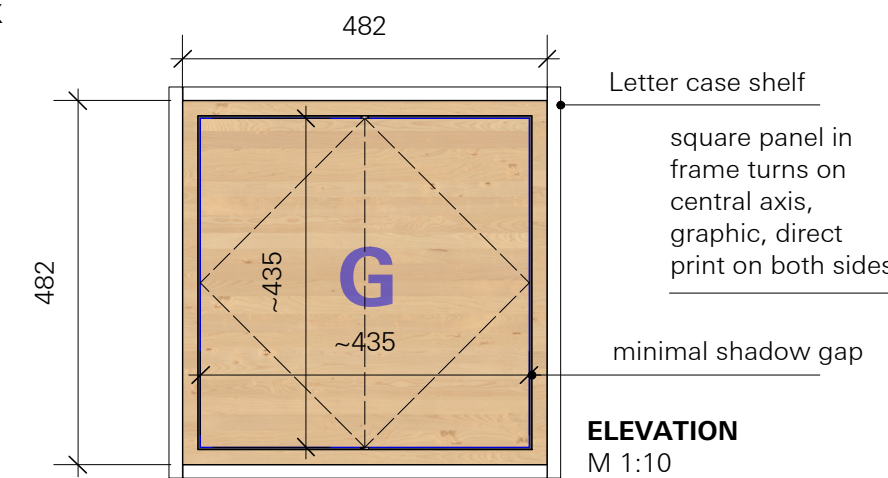

wood, acc. to material list

fitting for 360° truning

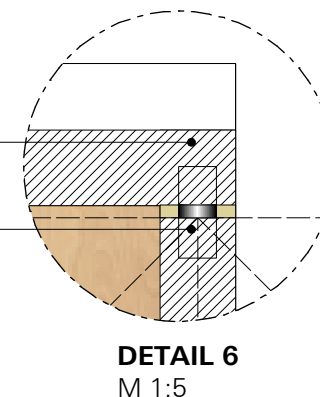

**LEGEND**

**SPECIALISTS**

M	MEDIEN
G	GRAPHIC
L	LIGHT
TGA	BUILDING TECHNOLOGY
	EXHIBITION ATB

**RELEASED**

All measurements have to be revised carefully by the contractor/executor and and compared with on-site situations. Differences concerning measurements or planning / stock have to be conveyed immediately to the designer. Details and drawings are only valid with annotation of approval by the designer.

**NORWEGIAN PRINTING MUSEUM**  
STAVANGER

**KEY PLAN**

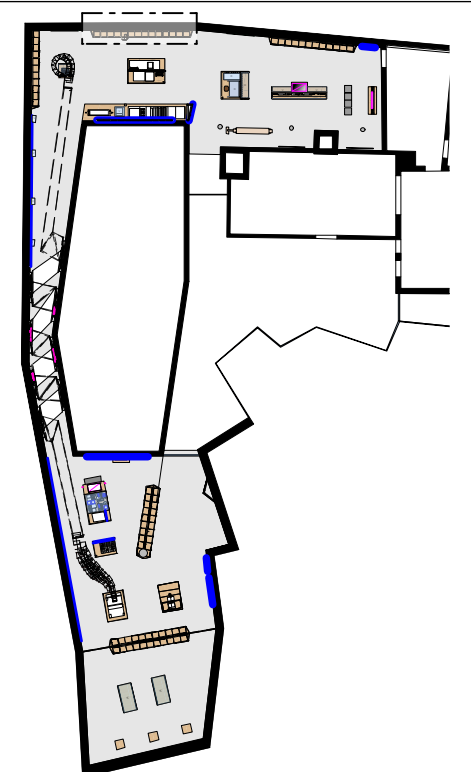

**DETAIL PLAN - SPECIAL SHELF COMPONENTS**  
LETTERCASE SHELF - MODULE D5/D7

**client** Museum Stavanger  
Øvre Strandgate 88  
4005 Stavanger I Norwegian  
T. +47 40 60 17 01  
www.museumstavanger.no  
bitten.bakke@museumstavanger.no

**planner exhibition szenopgraphy** ATELIER BRÜCKNER GMBH  
Krefelder Strasse 32  
70376 Stuttgart I Germany  
T. +49 711 5000 77 116  
F. +49 711 5000 77 22  
ngm@atelier-brueckner.com

papersize	scale	unit	sign
DIN A2	1:10/5/2	mm	sm

filename  
**NGM-ATB\_D\_1.5.2.0\_02**

date	code	planningphase
13.09.2019	NGM-ATB	LPH 4 - DD

type	hierarchy	no.	index
D	1.5.2.0	02	00

Please also see light planning Details!  
See plan: NGM-ATB/BH\_D\_1.1.0.0\_03