

UNLESS OTHERWISE SPECIFIED:
 DIMENSIONS ARE IN MILLIMETERS
 WEIGHT ARE IN KILOGRAMM

PART NUMBER / DWG NO.:
K002

	NAME	SIGNATURE	DATE	REVISION
DRAWN	M.Rebase		30.01.2013	
APPV'D				

DESCRIPTION:
Swing construction BELL-FLOWER

Tiptaptap OÜ
 Veetorni 9,
 Jüri alevik, Rae vald,
 75301 Harjumaa

MATERIAL:	wood, metal, plastic	A4
WEIGHT:	SCALE: 1:30	SHEET 1 OF 8

A

2880

B

C

2586

7800

D

E

3611

UNLESS OTHERWISE SPECIFIED:
DIMENSIONS ARE IN MILLIMETERS
WEIGHT ARE IN KILOGRAMM

PART NUMBER / DWG NO.:

K002

	NAME	SIGNATURE	DATE	REVISION
DRAWN	M.Rebase		30.01.2013	
APPV'D				

DESCRIPTION:

Swing construction BELL-FLOWER

F



Tiptiptap OÜ

Tiptiptap OÜ
Veetorni 9,
Jüri alevik, Rae vald,
75301 Harjumaa

MATERIAL:

wood, metal, plastic

A4

WEIGHT:

SCALE: 1:50

SHEET 2 OF 8

A

2880

B

500

700

C

2696

7800

D

E

3596

UNLESS OTHERWISE SPECIFIED:
DIMENSIONS ARE IN MILLIMETERS
WEIGHT ARE IN KILOGRAMM

PART NUMBER / DWG NO.:

K002

	NAME	SIGNATURE	DATE	REVISION
DRAWN	M.Rebase		30.01.2013	
APPV'D				

DESCRIPTION:

Swing construction BELL-FLOWER

F



Tiptaptap OÜ

Tiptaptap OÜ
Veetorni 9,
Jüri alevik, Rae vald,
75301 Harjumaa

MATERIAL:

wood, metal, plastic

A4

WEIGHT:

SCALE: 1:50

SHEET 3 OF 8

1

2

3

4

A

B

C

D

E

F

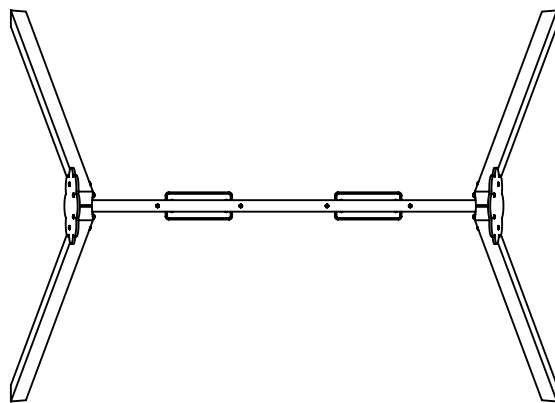
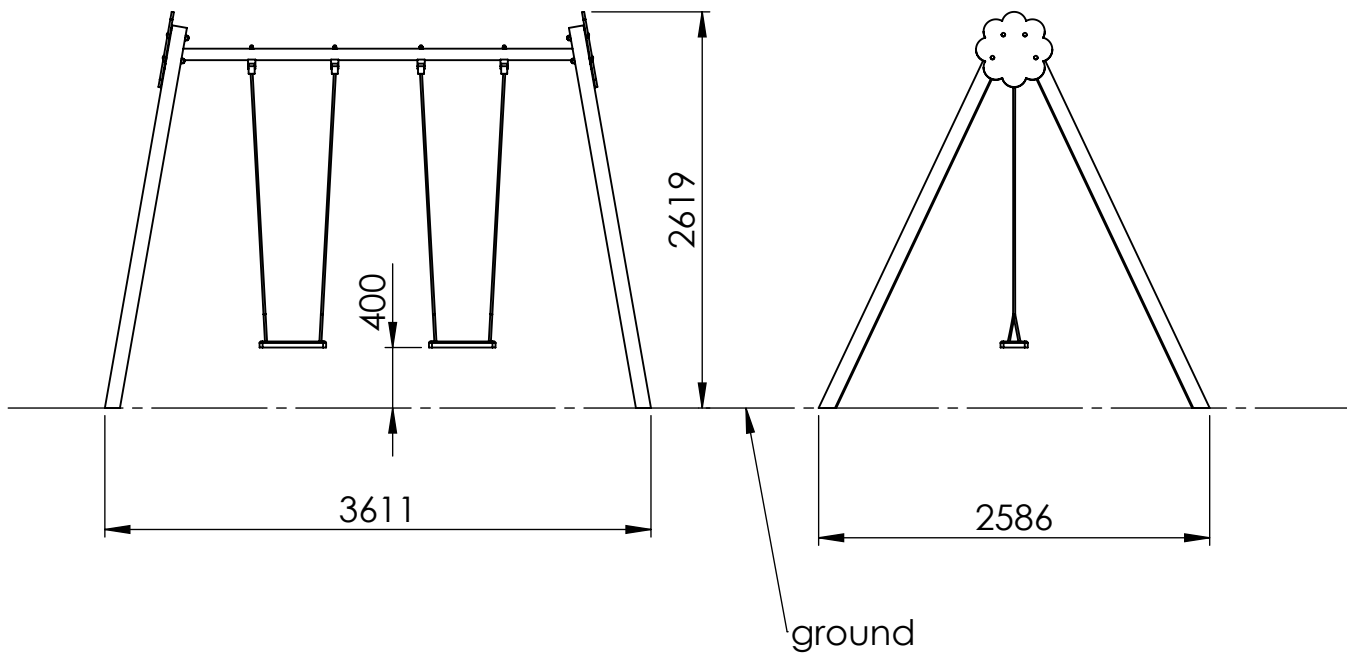

UNLESS OTHERWISE SPECIFIED:
DIMENSIONS ARE IN MILLIMETERS
WEIGHT ARE IN KILOGRAMM

PART NUMBER / DWG NO.:

K002

	NAME	SIGNATURE	DATE	REVISION
DRAWN	M.Rebase		30.01.2013	
APPV'D				

DESCRIPTION:

Swing construction BELL-FLOWER

MATERIAL:

wood, metal, plastic

A4

WEIGHT:

SCALE: 1:50

SHEET 4 OF 8



Tiptiptap OÜ

Tiptiptap OÜ
Veetorni 9,
Jüri alevik, Rae vald,
75301 Harjumaa

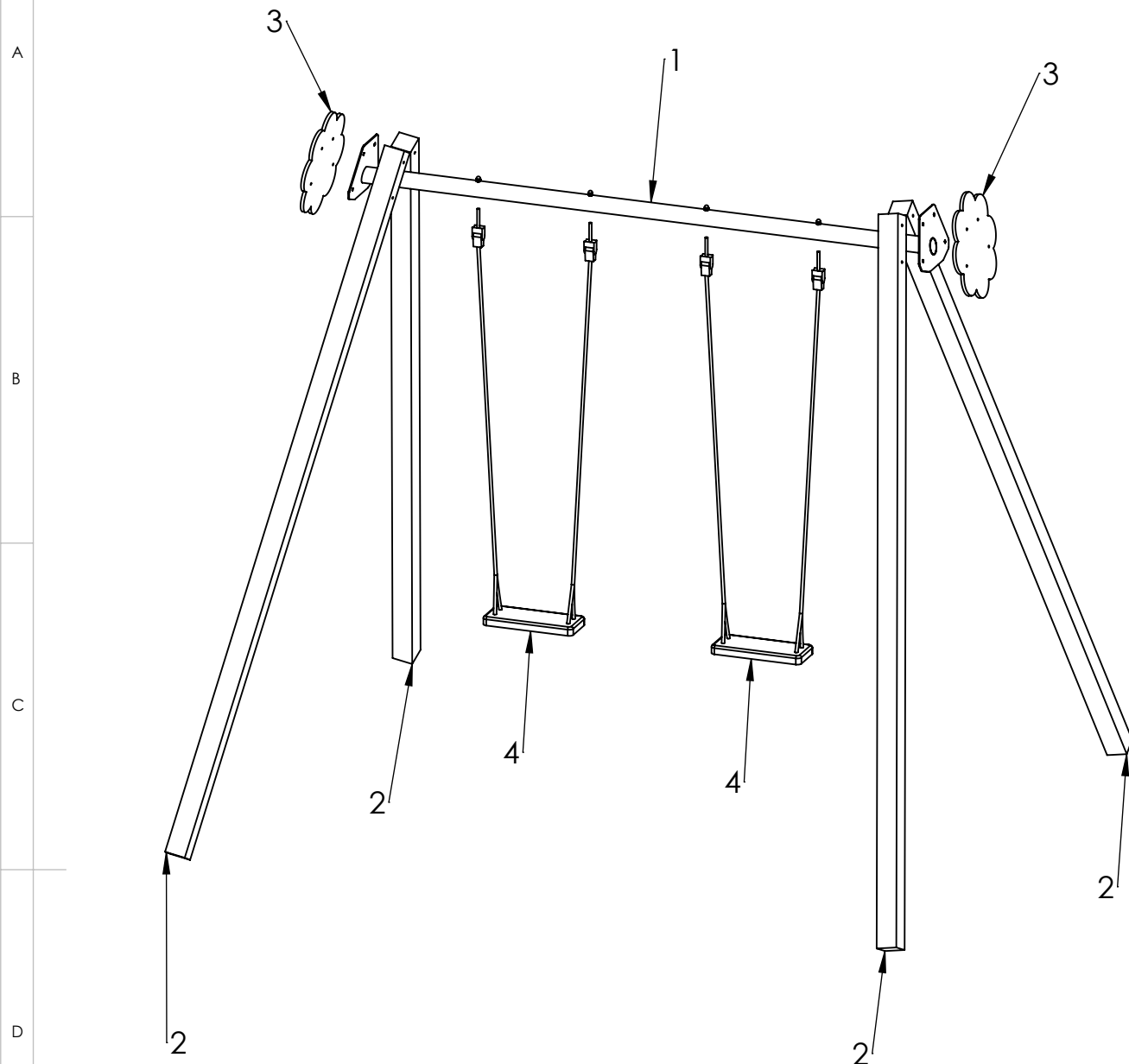

ITEM NO.	PART NUMBER	DESCRIPTION	QTY.
1	beam 76x2828	galvanized steel	1
2	post 98x98x3400	laminated wood	4
3	side fixture	plastic	2
4	seat complect with fittings	rubber compound with aluminium insert	2

UNLESS OTHERWISE SPECIFIED:
DIMENSIONS ARE IN MILLIMETERS
WEIGHT ARE IN KILOGRAMM

PART NUMBER / DWG NO.:

K002

	NAME	SIGNATURE	DATE	REVISION
DRAWN	M.Rebase		30.01.2013	
APPV'D				

DESCRIPTION:

Swing construction BELL-FLOWER



Tiptiptap OÜ

Tiptiptap OÜ
Veetorni 9,
Jüri alevik, Rae vald,
75301 Harjumaa

MATERIAL:

wood, metal, plastic

A4

WEIGHT:

SCALE: 1:30

SHEET 5 OF 8

A

B

C

D

E

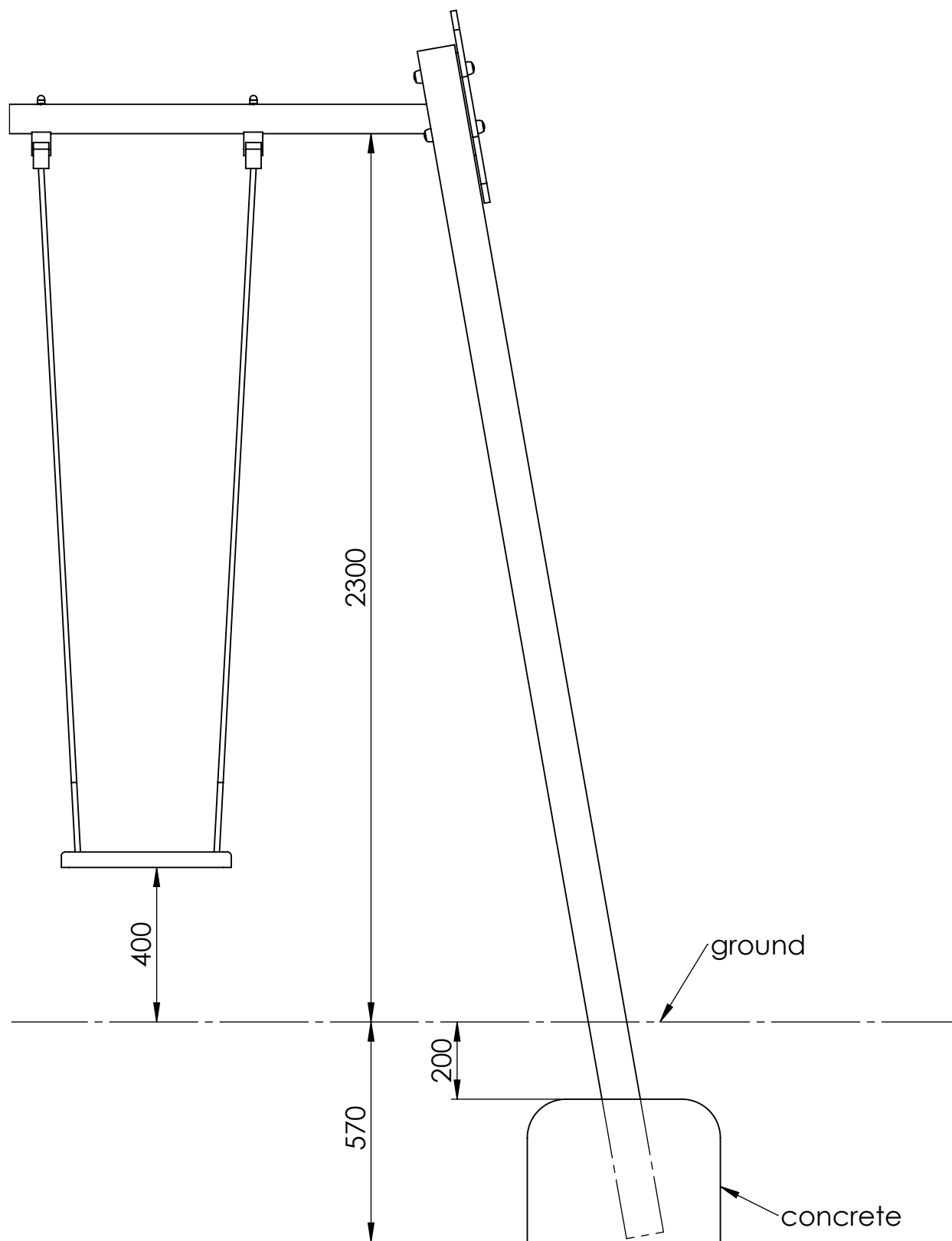

UNLESS OTHERWISE SPECIFIED:
DIMENSIONS ARE IN MILLIMETERS
WEIGHT ARE IN KILOGRAMM

PART NUMBER / DWG NO.:

K002

	NAME	SIGNATURE	DATE	REVISION
DRAWN	M.Rebase		30.01.2013	
APPV'D				

DESCRIPTION:

Swing construction BELL-FLOWER

F



Tiptaptap OÜ

Tiptaptap OÜ
Veetorni 9,
Jüri alevik, Rae vald,
75301 Harjumaa

MATERIAL:

wood, metal, plastic

A4

WEIGHT:

SCALE: 1:100

SHEET 6 OF 8

A

B

C

D

E

F

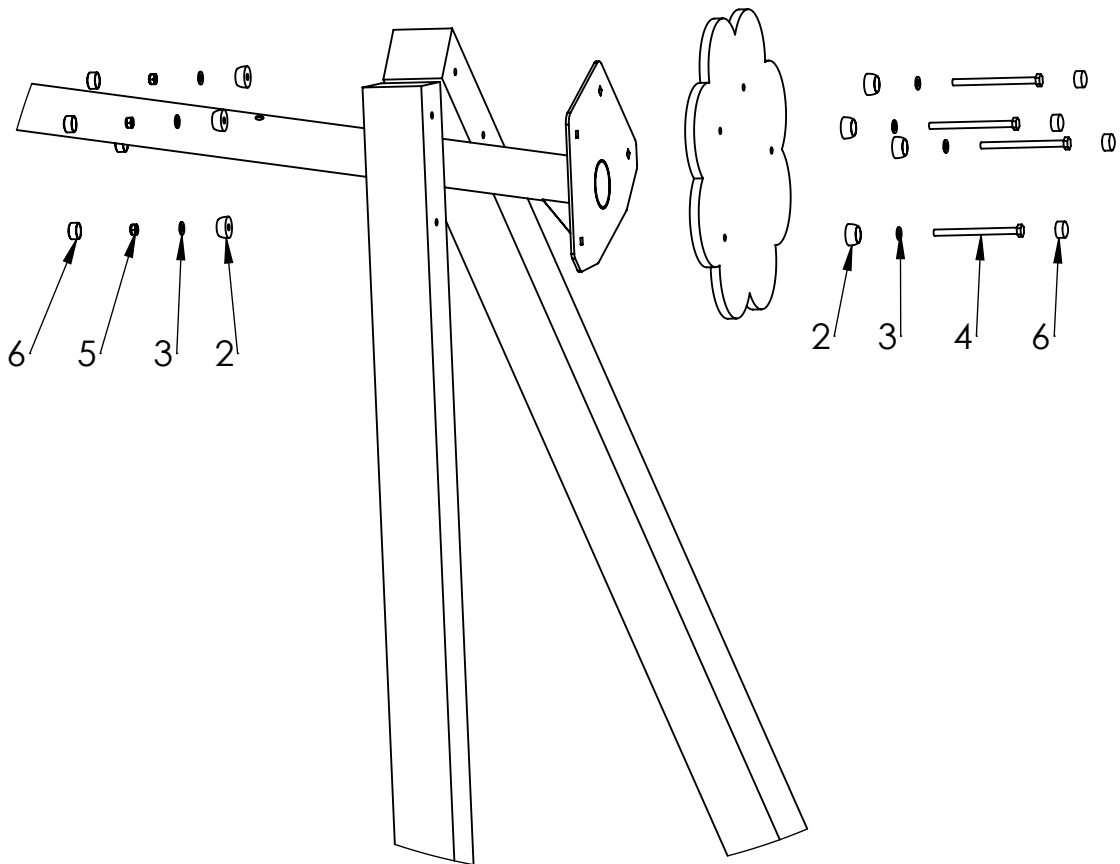

ITEM NO.	PART NUMBER
1	side fixture
2	nut cover M10
3	washer M10
4	bolt DIN931 M10x140
5	nut DIN985 M10
6	nut cover cap M10

UNLESS OTHERWISE SPECIFIED:
DIMENSIONS ARE IN MILLIMETERS
WEIGHT ARE IN KILOGRAMM

PART NUMBER / DWG NO.:

K002

	NAME	SIGNATURE	DATE	REVISION
DRAWN	M.Rebase		30.01.2013	
APPV'D				

DESCRIPTION:

Swing construction BELL-FLOWER

MATERIAL:

wood, metal, plastic

A4

WEIGHT:

SCALE: 1:100

SHEET 7 OF 8



Tiptap OÜ

Tiptap OÜ
Veetorni 9,
Jüri alevik, Rae vald,
75301 Harjumaa

A

B

C

D

E

F

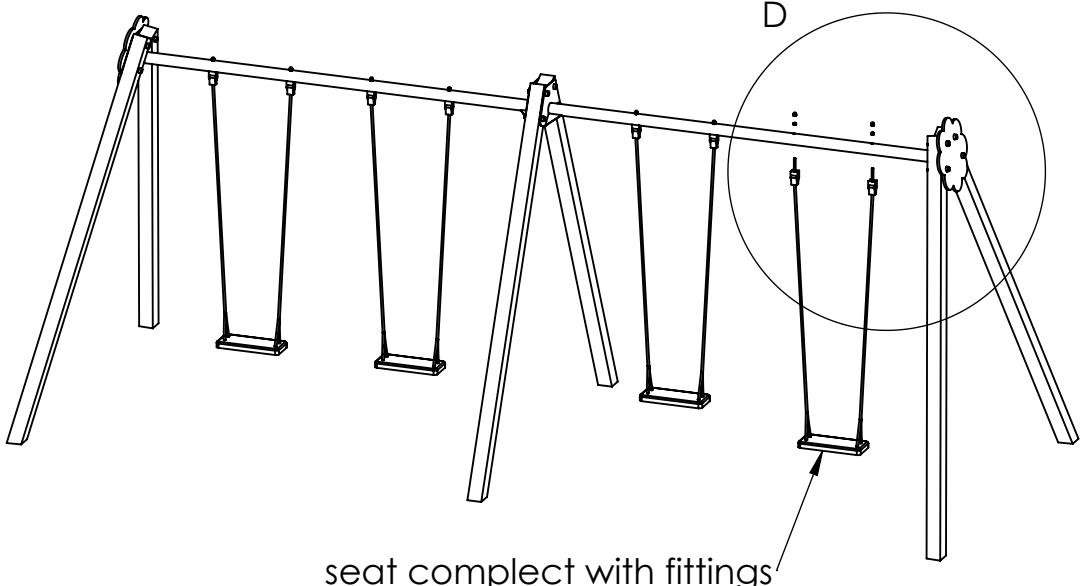

seat complete with fittings

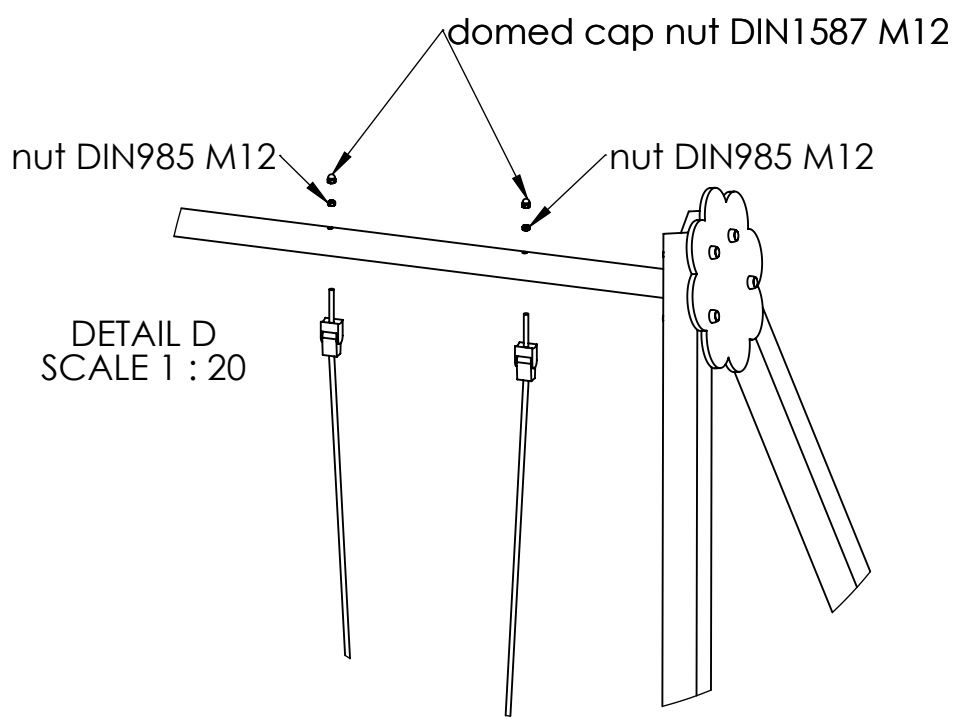

DETAIL D
SCALE 1 : 20

UNLESS OTHERWISE SPECIFIED:
DIMENSIONS ARE IN MILLIMETERS
WEIGHT ARE IN KILOGRAMM

PART NUMBER / DWG NO.:
K002

	NAME	SIGNATURE	DATE	REVISION
DRAWN	M.Rebase		30.01.2013	
APPV'D				

DESCRIPTION:
Swing construction BELL-FLOWER



Tiptaptap OÜ

Tiptaptap OÜ
Veetorni 9,
Jüri alevik, Rae vald,
75301 Harjumaa

MATERIAL:	wood, metal, plastic	A4
-----------	----------------------	----

WEIGHT:	SCALE: 1:50	SHEET 8 OF 8
---------	-------------	--------------